

A decorative graphic consisting of several overlapping, wavy lines in shades of teal and blue, flowing from the left side of the page towards the right.

Product Manual

Seagate® Kinetic HDD

Standard model

ST4000NK001

100764174
Rev. A
October 2014

Document Revision History

Revision	Date	Description of changes
Rev. A	10/16/2014	Initial release.

© 2014 Seagate Technology LLC. All rights reserved.

Publication number: 100764174, Rev. A October 2014

Seagate, Seagate Technology and the Wave logo are registered trademarks of Seagate Technology LLC in the United States and/or other countries. SeaTools is a trademarks of Seagate Technology LLC or one of its affiliated companies in the United States and/or other countries. All other trademarks or registered trademarks are the property of their respective owners.

No part of this publication may be reproduced in any form without written permission of Seagate Technology LLC.
Call 877-PUB-TEK1(877-782-8351) to request permission.

When referring to drive capacity, one gigabyte, or GB, equals one billion bytes and one terabyte, or TB, equals one trillion bytes. Your computer's operating system may use a different standard of measurement and report a lower capacity. In addition, some of the listed capacity is used for formatting and other functions, and thus will not be available for data storage. Actual quantities will vary based on various factors, including file size, file format, features and application software. Actual data rates may vary depending on operating environment and other factors. The export or re-export of hardware or software containing encryption may be regulated by the U.S. Department of Commerce, Bureau of Industry and Security (for more information, visit www.bis.doc.gov), and controlled for import and use outside of the U.S. Seagate reserves the right to change, without notice, product offerings or specifications.

Contents

Seagate® Technology Support Services	5
<hr/>	
1.0 Introduction	6
1.1 About the Ethernet Interface	6
<hr/>	
2.0 Drive Specifications	7
2.1 Formatted Capacity	7
2.2 Recording and Interface Technology	7
2.3 Physical Characteristics	7
2.4 Power Specifications	8
2.4.1 Power consumption	8
2.4.2 Conducted Noise	8
2.4.3 Voltage Tolerance	8
2.5 Environmental Limits	9
2.5.1 Ambient Temperature	9
2.5.2 Humidity	10
2.5.3 Altitude	10
2.5.4 Shock	10
2.5.5 Vibration	10
2.6 Acoustics	11
2.7 Test for Prominent Discrete Tones (PDTs)	11
2.8 Electromagnetic immunity	11
2.9 Reliability	12
2.9.1 Annualized Failure Rate (AFR) and Mean Time Between Failures (MTBF) ...	12
2.10 Agency Certification	13
2.10.1 Safety certification	13
2.10.2 Electromagnetic compatibility	13
2.10.3 FCC verification	13
2.11 Environmental protection	14
2.11.1 European Union Restriction of Hazardous Substances (RoHS) Directive	14
2.11.2 China Restriction of Hazardous Substances (RoHS) Directive	14
2.12 Corrosive Environment	14
2.13 Product Warranty	15
<hr/>	
3.0 Configuring and Mounting the Drive	16
3.1 Handling and Static-Discharge Precautions	16
3.2 Drive Mounting	16
3.3 Drive Configurations	17
<hr/>	
4.0 Ethernet Enabled Interface	18
4.1 SAS Connector Physical Interface	18
<hr/>	
5.0 Key/Value Protocol	21
5.1 Host to Drive Data Transfer	21
5.2 Kinetic Protocol Data Unit	22
5.3 Kinetic Message	23
5.4 Command Embedded Message	23

Tables

Table 1.	HDD Capacity Information	7
Table 2.	Recording and Interface Specifications	7
Table 3.	Physical Characteristics	7
Table 4.	DC Power Requirements	8
Table 5.	Humidity Specifications	10
Table 6.	Altitude Specifications	10
Table 7.	Operating Vibration Specifications	10
Table 8.	Non-Operating Vibration Specifications	10
Table 9.	Fluid Dynamic Bearing (FDB) Motor Acoustics	11
Table 10.	Radio Frequency Environments	11
Table 11.	AFR and MTBF Specifications	12
Table 12.	Ethernet Enabled SAS Connector Pin Definitions	20
Table 13.	Kinetic PDU Structure	22

Figures

- Figure 1. Location of HDA Temperature Check Point 9
- Figure 2. HDD Mounting Dimensions 17
- Figure 3. SAS Device Plug Dimensions 18
- Figure 4. Detailed SAS Device Plug Dimensions 19
- Figure 5. SAS Connector Pin Locations 20
- Figure 6. Kinetic Software Stack 21
- Figure 7. Kinetic Protocol Data Unit Message Packet 22
- Figure 8. Command Embedded Message 23

Seagate® Technology Support Services

For information regarding online support and services, visit: <http://www.seagate.com/about/contact-us/technical-support/>

Available services include:

- Presales & Technical support
- Global Support Services telephone numbers & business hours
- Authorized Service Centers

For information regarding Warranty Support, visit: <http://www.seagate.com/support/warranty-and-replacements/>

For information regarding data recovery services, visit: <http://www.seagate.com/services-software/data-recovery-services/>

For Seagate OEM and Distribution partner portal, visit: <http://www.seagate.com/partners/>

For Seagate reseller portal, visit: <http://www.seagate.com/partners/my-spp-dashboard/>

1.0 INTRODUCTION

This manual describes the functional, mechanical and interface specifications for the following: Seagate® Kinetic HDD model drives:

Model Number	Seagate Instant Secure Erase (ISE)
ST4000NK0001	Yes

These drives provide the following key features:

- 5900 RPM spindle speed.
- High instantaneous (burst) data-transfer rates (up to 60MB per second).
- Perpendicular recording technology provides the drives with increased areal density.
- State-of-the-art cache and on-the-fly error-correction algorithms.
- Simple GetLog command usage to obtain logged data information stored in device.
- Supports Ethernet enabled SAS connectors (Connector pins shown in Table 4.1.1).
- State-free Key-Value Object Store with Remote Procedure Calls (RPC).
- Worldwide Name (WWN) capability uniquely identifies the drive.
- Easy communication via Kinetic Application Programming Interface libraries.

1.1 ABOUT THE ETHERNET INTERFACE

The Ethernet provides advantages over traditional SATA and SAS interfaces. The primary advantages include:

- Connects storage directly into existing data center fabric
- Allows direct TCP/IP communication from any node in the network to the storage device
- Eliminates traditional storage server needs as protocol communication
- Retains the standard SAS hardware interface connector to provide system builder adaptability, while enabling Ethernet

2.0 DRIVE SPECIFICATIONS

Unless otherwise noted, all specifications are measured under ambient conditions, at 25°C, and nominal power. For convenience, the phrases *the drive* and *this drive* are used throughout this manual to indicate the following drive models:

Seagate SED model
ST4000NK0001

2.1 FORMATTED CAPACITY

Table 1: HDD Capacity Information

Model	Formatted capacity*	Guaranteed Objects	Bytes per Object
ST4000NK0001	4TB	3,906,250	Up to 1024KB

*One GB equals one billion bytes and 1TB equals one trillion bytes when referring to hard drive capacity. Accessible capacity may vary depending on operating environment and formatting.

2.2 RECORDING AND INTERFACE TECHNOLOGY

Table 2: Recording and Interface Specifications

Interface	1-Gbps SGMII Ethernet
Recording method	Perpendicular
Recording density, KBPI (Kb/in max)	1807
Track density, KTPI (ktracks/in avg)	340
Areal density (Gb/in ² avg)	625
Spindle speed (RPM) (± 0.2%)	5900
Internal data transfer rate (Mb/s max)	1813
Sustained data transfer rate (MiB/s)	20 to 60
I/O data-transfer rate (MB/s max)	60

2.3 PHYSICAL CHARACTERISTICS

Table 3: Physical Characteristics

Weight: (maximum)	
Kinetic 4TB Model	608g (1.34 lb)
Cache buffer	64MB (67,108,864B)
RAM	512 MB (536,870,912B)
Software-on-Chip	Marvell ARMADA 370

2.4 POWER SPECIFICATIONS

- The drive receives DC power (+5V or +12V) through the Ethernet enabled SAS device connector.
- Three +12 volt pins provide power to the drive, 2 short and 1 long. The current return for the +12 volt power supply is through the common ground pins. The supply current and return current must be distributed as evenly as possible among the pins.
- Three +5 volt pins provide power to the drive, 2 short and 1 long. The current return for the +5 volt power supply is through the common ground pins. The supply current and return current must be distributed as evenly as possible among the pins.
- Current to the drive through the long power pins may be limited by the system to reduce inrush current to the drive during hot plugging.

2.4.1 Power consumption

- Power requirements for the drives are listed in Table 2.5.1. Typical power measurements are based on an average of drives tested, under nominal conditions, using 5.0V and 12.0V input voltage at 25°C ambient temperature.
- Spinup power:
Spinup power is measured from the time of power-on to the time that the drive spindle reaches operating speed.
- Average Current Put / Get:
Drive operation consisted of continuous PUT / GET operations, 50/50 duty cycle.

Table 4: DC Power Requirements

		1.0Gb Mode	
Voltage		+5V	+12V
Regulation		±5%	±10%
Maximum Spin-up Power			
	Peak DC (Watts)	3σ 5.0	19.2
Average Power (Put/Get)			
	Typical DC (Watts)	3σ 4.25	3.60

2.4.2 Conducted Noise

Input noise ripple is measured at the host system power supply across an equivalent 80-ohm resistive load on the +12 volt line or an equivalent 15-ohm resistive load on the +5 volt line.

Using 12-volt power, the drive is expected to operate with a maximum of 120 mV peak-to-peak square-wave injected noise at up to 10MHz.

Using 5-volt power, the drive is expected to operate with a maximum of 100 mV peak-to-peak square-wave injected noise at up to 10MHz.

Note	Equivalent resistance is calculated by dividing the nominal voltage by the typical RMS read/write current.
-------------	--

2.4.3 Voltage Tolerance

Voltage Tolerance (including noise):

- 5V ± 5%
- 12V ± 10%

2.5 ENVIRONMENTAL LIMITS

Temperature and humidity values experienced by the drive must be such that condensation does not occur on any drive part. Altitude and atmospheric pressure specifications are referenced to a standard day at 58.7°F (14.8°C). Maximum wet bulb temperature is 82°F (28°C).

Note	The recommended storage period: <ul style="list-style-type: none">• 1 year under controlled conditions of 34°C 90%RH or less• 90 days in uncontrolled storage conditions
-------------	---

2.5.1 Ambient Temperature

Operating

The drive meets the operating specifications over a 41°F to 140°F (5°C to 60°C) drive case temperature range with a maximum temperature gradient of 36°F (20°C) per hour.

The maximum allowable drive case temperature is 60°C. See Figure 2.5.1 for HDA case temperature measurement location

The MTBF specification for the drive assumes the operating environment is designed to maintain nominal case temperature. The rated MTBF is based upon a sustained case temperature of 104°F (40°C). Occasional excursions in operating temperature between the rated MTBF temperature and the maximum drive operating case temperature may occur without impact to the rated MTBF. However, continual or sustained operation at case temperatures beyond the rated MTBF temperature will degrade the drive MTBF and reduce product reliability.

Air flow may be required to achieve consistent nominal case temperature values. To confirm that the required cooling is provided for the electronics and HDA, place the drive in its final mechanical configuration, and perform random write/read operations. After the temperatures stabilize, measure the case temperature of the drive.

Non-operating

–40° to 158°F (–40° to 70°C) package ambient with a maximum gradient of 36°F (20°C) per hour. This specification assumes that the drive is packaged in the shipping container designed by Seagate for use with drive.

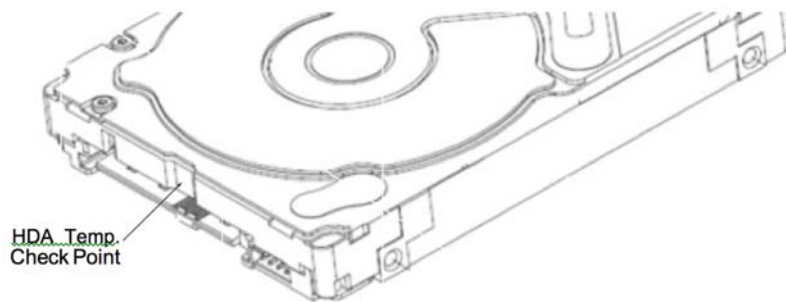

Figure 1 Location of HDA Temperature Check Point

Note	Image is for reference only, may not represent actual drive
-------------	---

2.5.2 Humidity

Table 5: Humidity Specifications

Operating	5% to 90% non-condensing (30% per hour max)
Non-Operating	5% to 95% non-condensing (30% per hour max)

2.5.3 Altitude

Table 6: Altitude Specifications

Operating	-304.80 m to 3048 m (-1000 ft. to 10,000+ ft.)
Non-Operating	-304.80 m to 12,192 m (-1000 ft. to 40,000+ ft.)

2.5.4 Shock

All shock specifications assume that the drive is mounted securely with the input shock applied at the drive mounting screws. Shock may be applied in the X, Y or Z axis.

2.5.4.1 Operating Shock

These drives comply with the performance levels specified in this document when subjected to a maximum operating shock of 70 Gs (read) and 40 Gs (write) based on half-sine shock pulses of 2 ms during read operations. Shocks should not be repeated more than two times per second.

2.5.4.2 Non-Operating Shock

The non-operating shock level that the drive can experience without incurring physical damage or degradation in performance when subsequently put into operation is 300 Gs based on a non-repetitive half-sine shock pulse of 2 ms duration.

2.5.5 Vibration

All vibration specifications assume that the drive is mounted securely with the input vibration applied at the drive mounting screws. Vibration may be applied in the X, Y or Z axis.

2.5.5.1 Operating Vibration

The maximum vibration levels that the drive may experience while meeting the performance standards specified in this document are specified below.

Table 7: Operating Vibration Specifications

5Hz to 22Hz	0.25 Gs
22Hz to 350Hz	0.50 Gs
350Hz to 500Hz	0.25 Gs
20Hz – 1500 Hz *(RROV)	12.5 rads/s ² with RVFF

* Rotary Random Operating Vibration

All vibration specifications assume that the drive is mounted securely with the input vibration applied at the drive mounting screws. Vibration may be applied in the X, Y or Z axis. Throughput may vary if improperly mounted.

2.5.5.2 Non-Operating Vibration

The maximum non-operating vibration levels that the drive may experience without incurring physical damage or degradation in performance when subsequently put into operation are specified below.

Table 8: Non-Operating Vibration Specifications

10 Hz to 500 Hz Linear Random	4.9 Grms ref
-------------------------------	--------------

2.6 ACOUSTICS

Drive acoustics are measured as overall A-weighted acoustic sound power levels (no pure tones). All measurements are consistent with ISO document 7779. Sound power measurements are taken under essentially free-field conditions over a reflecting plane. For all tests, the drive is oriented with the cover facing upward.

Note	<p>For seek mode tests, the drive is placed in seek mode only. The number of seeks per second is defined by the following equation:</p> <p>Number of seeks per second = $0.4 / (\text{average latency} + \text{average access time})$</p>
-------------	--

Table 9: Fluid Dynamic Bearing (FDB) Motor Acoustics

	Idle*	Put / Get Seek
4 Disks (4TB)	2.3 bels (typical) 2.5 bels (max)	2.8 bels (typical) 3.0 bels (max)

*During periods of drive idle, some offline activity may occur, which may increase acoustic and power to operational levels.

2.7 TEST FOR PROMINENT DISCRETE TONES (PDTs)

Seagate follows the ECMA-74 standards for measurement and identification of PDTs. An exception to this process is the use of the absolute threshold of hearing. Seagate uses this threshold curve (originated in ISO 389-7) to discern tone audibility and to compensate for the inaudible components of sound prior to computation of tone ratios according to Annex D of the ECMA-74 standards.

2.8 ELECTROMAGNETIC IMMUNITY

When properly installed in a representative host system, the drive operates without errors or degradation in performance when subjected to the radio frequency (RF) environments defined in Table 2.9.1

Table 10: Radio Frequency Environments

Test	Description	Performance level	Reference standard
Electrostatic discharge	Contact, HCP, VCP: ± 4 kV; Air: ± 8 kV	B	EN61000-4-2: 95
Radiated RF immunity	80MHz to 1,000MHz, 3 V/m, 80% AM with 1kHz sine 900MHz, 3 V/m, 50% pulse modulation @ 200Hz	A	EN61000-4-3: 96 ENV50204: 95
Electrical fast transient	± 1 kV on AC mains, ± 0.5 kV on external I/O	B	EN61000-4-4: 95
Surge immunity	± 1 kV differential, ± 2 kV common, AC mains	B	EN61000-4-5: 95
Conducted RF immunity	150kHz to 80MHz, 3 Vrms, 80% AM with 1kHz sine	A	EN61000-4-6: 97
Voltage dips, interrupts	0% open, 5 seconds	C	EN61000-4-11: 94
	0% short, 5 seconds	C	
	40%, 0.10 seconds	C	
	70%, 0.01 seconds	B	

2.9 RELIABILITY

2.9.1 Annualized Failure Rate (AFR) and Mean Time Between Failures (MTBF)

The product shall achieve an Annualized Failure Rate (AFR) of 1.1% (MTBF of 800 thousand hours) when operated at nominal power and typical case temperatures of 40°C. Operation at temperatures outside the specifications in Section 2.8 may increase the product AFR (decrease MTBF). AFR and MTBF are population statistics that are not relevant to individual units.

AFR and MTBF specifications are based on the following assumptions for business critical storage system environments:

- 8760 power-on-hours per year.
- Operations at nominal voltages.
- Temperatures outside the specifications in Section 2.8 may reduce the product reliability.
- A workload rate below the average annualized specified limits. Operation at excessive I/O duty cycle may degrade product reliability.
- The enterprise application environment of power-on-hours, temperature, and I/O duty cycle effects the product AFR and MTBF.

Table 11: AFR and MTBF Specifications

Nonrecoverable read errors	1 per 10 ¹⁴ bits read, max
Annualized Failure Rate	1.1% (nominal power, 40°C case temperature)
Load unload cycles	300,000 cycles
Rated Workload	Average rate of <180TB/year The MTBF specification for the drive assumes the I/O workload does not exceed the Average Annualized Workload Rate Limit of <180TB/year. Workloads exceeding the annualized rate may degrade the drive MTBF and impact product reliability. The Average Annualized Workload Rate Limit is in units of TB per year, or TB per 8760 power on hours. Workload Rate = TB transferred x (8760 / recorded power on hours).
Warranty	To determine the warranty for a specific drive, use a web browser to access the following web page: http://www.seagate.com/support/warranty-and-replacements/ . From this page, click on the “Check to see if the drive is under Warranty” link. The following are required to be provided: the drive serial number, model number (or part number) and country of purchase. The system will display the warranty information for the drive.
Preventive maintenance	None required.

2.10 AGENCY CERTIFICATION

2.10.1 Safety certification

These products are certified to meet the requirements of UL60950-1, CSA60950-1 and EN60950 and so marked as to the certify agency.

2.10.2 Electromagnetic compatibility

The Seagate Kinetic HDD hard drives are tested to a Class A standard per the CISPR 22 specification. Per the CISPR 22 specification “Class A ITE is a category of all other ITE which satisfies the class A ITE limits but not the class B ITE limits. Warning – This is a class A product. In a domestic environment this product may cause radio interference in which case the user may be required to take adequate measures.”

Drives are tested in representative end-user systems. Although CE-marked Seagate drives comply with the directives when used in the test systems, we cannot guarantee that all systems will comply with the directives. The drive is designed for operation inside a properly designed enclosure, with properly shielded I/O cable (if necessary) and terminators on all unused IO ports. Computer manufacturers and system integrators should confirm EMC compliance and provide CE marking for their products.

Korean RRL

If these drives have the Korean Communications Commission (KCC) logo, they comply with paragraph 1 of Article 11 of the Electromagnetic Compatibility control Regulation and meet the Electromagnetic Compatibility (EMC) Framework requirements of the Radio Research Laboratory (RRL) Communications Commission, Republic of Korea.

These drives have been tested and comply with the Electromagnetic Interference/Electromagnetic Susceptibility (EMI/EMS) for Class A products. Drives are tested in a representative, end-user system by a Korean-recognized lab.

Australian Regulatory Compliance Mark (RCM)

If these models have the RCM marking, they comply with the Australia/New Zealand Standard AS/NZ CISPR22 and meet the Electromagnetic Compatibility (EMC) Framework requirements of the Australian Communications and Media Authority (ACMA).

2.10.3 FCC verification

These drives are intended to be contained solely within an enclosure (not attached as an external device). As such, each drive is considered to be a subassembly even when it is individually marketed to the customer. As a subassembly, no Federal Communications Commission verification or certification of the device is required.

Seagate has tested this device in enclosures as described above to ensure that the total assembly (enclosure, disk drive motherboard, power supply, etc.) does comply with the limits for a Class A ITE device.

Radio and television interference. This equipment generates and uses radio frequency energy and if not installed and used in strict accordance with the manufacturer’s instructions, may cause interference to radio and television reception.

This equipment is designed to provide reasonable protection against such interference in a residential installation.

However there is no guarantee that interference will not occur in a particular installation. If this equipment does cause interference to radio or television, which can be determined by turning the equipment on and off, users are encouraged to try one or more of the following corrective measures:

- Reorient the receiving antenna.
- Move the device to one side or the other of the radio or TV.
- Move the device farther away from the radio or TV.
- Plug the computer into a different outlet so that the receiver and computer are on different branch outlets.

If necessary, users should consult the dealer or an experienced radio/television technician for additional suggestions. Users may find helpful the following booklet prepared by the Federal Communications Commission: *How to Identify and Resolve Radio-Television Interference Problems*. This booklet is available from the Superintendent of Documents, U.S. Government Printing Office, Washington, DC 20402. Refer to publication number 004-000-00345-4.

2.11 ENVIRONMENTAL PROTECTION

Seagate designs its products to meet environmental protection requirements worldwide, including regulations restricting certain chemical substances.

2.11.1 European Union Restriction of Hazardous Substances (RoHS) Directive

The European Union Restriction of Hazardous Substances (RoHS) Directive, restricts the presence of chemical substances including Lead, Cadmium, Mercury, Hexavalent Chromium, PBB and PBDE, in electronic products, effective July 2006. This drive is manufactured with components and materials that comply with the RoHS Directive.

2.11.2 China Restriction of Hazardous Substances (RoHS) Directive 中国限制危险物品的指令

This product has an Environmental Protection Use Period (EPUP) of 20 years. The following table contains information mandated by China's "Marking Requirements for Control of Pollution Caused by Electronic Information Products" Standard.



该产品具有20年的环境保护使用周期（EPUP）。下表包含了中国“电子产品所导致的污染的控制的记号要求”所指定的信息。

Name of Parts 部件名称	Toxic or Hazardous Substances or Elements有毒有害物质或元素					
	Lead 铅 (Pb)	Mercury 汞 (Hg)	Cadmium 镉 (Cd)	Hexavalent Chromium 六价铬 (Cr6+)	Polybrominated Diphenyl 多溴联苯 (PBB)	Polybrominated Diphenyl Ether 多溴二苯醚 (PBDE)
PCBA	X	O	O	O	O	O
HDA	X	O	O	O	O	O

"O" indicates the hazardous and toxic substance content of the part (at the homogeneous material level) is lower than the threshold defined by the China RoHS MCV Standard.

“O”表示该部件（于同类物品程度上）所含的危险和有毒物质低于中国RoHS MCV标准所定义的阈值。

"X" indicates the hazardous and toxic substance content of the part (at the homogeneous material level) is over the threshold defined by the China RoHS MCV Standard.

“X”表示该部件（于同类物品程度上）所含的危险和有毒物质超出中国RoHS MCV标准所定义的阈值。

2.12 CORROSIVE ENVIRONMENT

Seagate electronic drive components pass accelerated corrosion testing equivalent to 10 years exposure to light industrial environments containing sulfurous gases, chlorine and nitric oxide, classes G and H per ASTM B845. However, this accelerated testing cannot duplicate every potential application environment. Users should use caution exposing any electronic components to uncontrolled chemical pollutants and corrosive chemicals, as the installation environment can affect electronic drive component reliability. The silver, copper, nickel and gold films used in Seagate products are especially sensitive to the presence of sulfide, chloride, and nitrate contaminants. Sulfur is found to be the most damaging. In addition electronic components should never be exposed to condensing water on the surface of the printed circuit board assembly (PCBA) or exposed to an ambient relative humidity greater than 95%. Materials used in cabinet fabrication, such as vulcanized rubber, that can outgas corrosive compounds should be minimized or eliminated. Replacing materials near circuitry with sulfide-free alternatives may extend the useful life of any electronic equipment.

2.13 PRODUCT WARRANTY

Beginning on the date of shipment to the customer and continuing for the period specified in the purchase contract, Seagate warrants that each product (including components and subassemblies) that fails to function properly under normal use due to defect in materials or workmanship or due to nonconformance to the applicable specifications will be repaired or replaced, at Seagate's option and at no charge to the customer, if returned by customer at customer's expense to Seagate's designated facility in accordance with Seagate's warranty procedure. Seagate will pay for transporting the repair or replacement item to the customer. For more detailed warranty information, refer to the standard terms and conditions of purchase for Seagate products on the purchase documentation.

The remaining warranty for a particular drive can be determined by calling Seagate Customer Service at 1-800-468-3472. Users can also determine remaining warranty using the Seagate web site (www.seagate.com). The drive serial number is required to determine remaining warranty information.

Shipping

When transporting or shipping a drive, use only a Seagate-approved container. Keep the original box. Seagate approved containers are easily identified by the Seagate Approved Package label. Shipping a drive in a non-approved container voids the drive warranty.

Seagate repair centers may refuse receipt of components improperly packaged or obviously damaged in transit. Contact the authorized Seagate distributor to purchase additional boxes. Seagate recommends shipping by an air-ride carrier experienced in handling computer equipment.

Storage

The maximum recommended storage period for the drive in a non-operational environment is 90 days. Drives should be stored in the original unopened Seagate shipping packaging whenever possible. Once the drive is removed from the Seagate original packaging the recommended maximum period between drive operation cycles is 30 days. During any storage period the drive non-operational temperature, humidity, wet bulb, atmospheric conditions, shock, vibration, magnetic and electrical field specifications should be followed.

Product Repair and Return Information

Seagate customer service centers are the only facilities authorized to service Seagate drives. Seagate does not sanction any third-party repair facilities. Any unauthorized repair or tampering with the factory seal voids the warranty.

3.0 CONFIGURING AND MOUNTING THE DRIVE

This section contains the specifications and instructions for configuring and mounting the drive.

3.1 HANDLING AND STATIC-DISCHARGE PRECAUTIONS

After unpacking, and before installation, the drive may be exposed to potential handling and electrostatic discharge (ESD) hazards. Observe the following standard handling and static-discharge precautions:

Caution	<ul style="list-style-type: none">• Before handling the drive, put on a grounded wrist strap. Wear a grounded wrist strap throughout the entire installation procedure.• Handle the drive by its edges or frame <i>only</i>.• The drive is extremely fragile—handle it with care. Do not press down on the drive top cover.• Always rest the drive on a padded, antistatic surface until users mount it in the computer.• Do not touch the connector pins or the printed circuit board.• Do not remove the factory-installed labels from the drive or cover them with additional labels. Removal voids the warranty. Some factory-installed labels contain information needed to service the drive. Other labels are used to seal out dirt and contamination.
----------------	--

3.2 DRIVE MOUNTING

Users can mount the drive in any orientation using four screws in the side-mounting holes or four screws in the bottom-mounting holes. Refer to Figure 3.2.1 for drive mounting dimensions. Follow these important mounting precautions when mounting the drive:

- Allow a minimum clearance of 0.030 inches (0.76mm) around the entire perimeter of the drive for cooling.
- Use only 6-32 UNC mounting screws.
- The screws should be inserted no more than 0.150 inches (3.81mm) into the bottom or side mounting holes.
- Do not over tighten the mounting screws (maximum torque: 6 inch-lb).

Weight:	608g (1.34 lb)
---------	----------------

Note	These dimensions conform to the Small Form Factor Standard documented in SFF-8301 and SFF-8323 found at www.sffcommittee.org
-------------	--

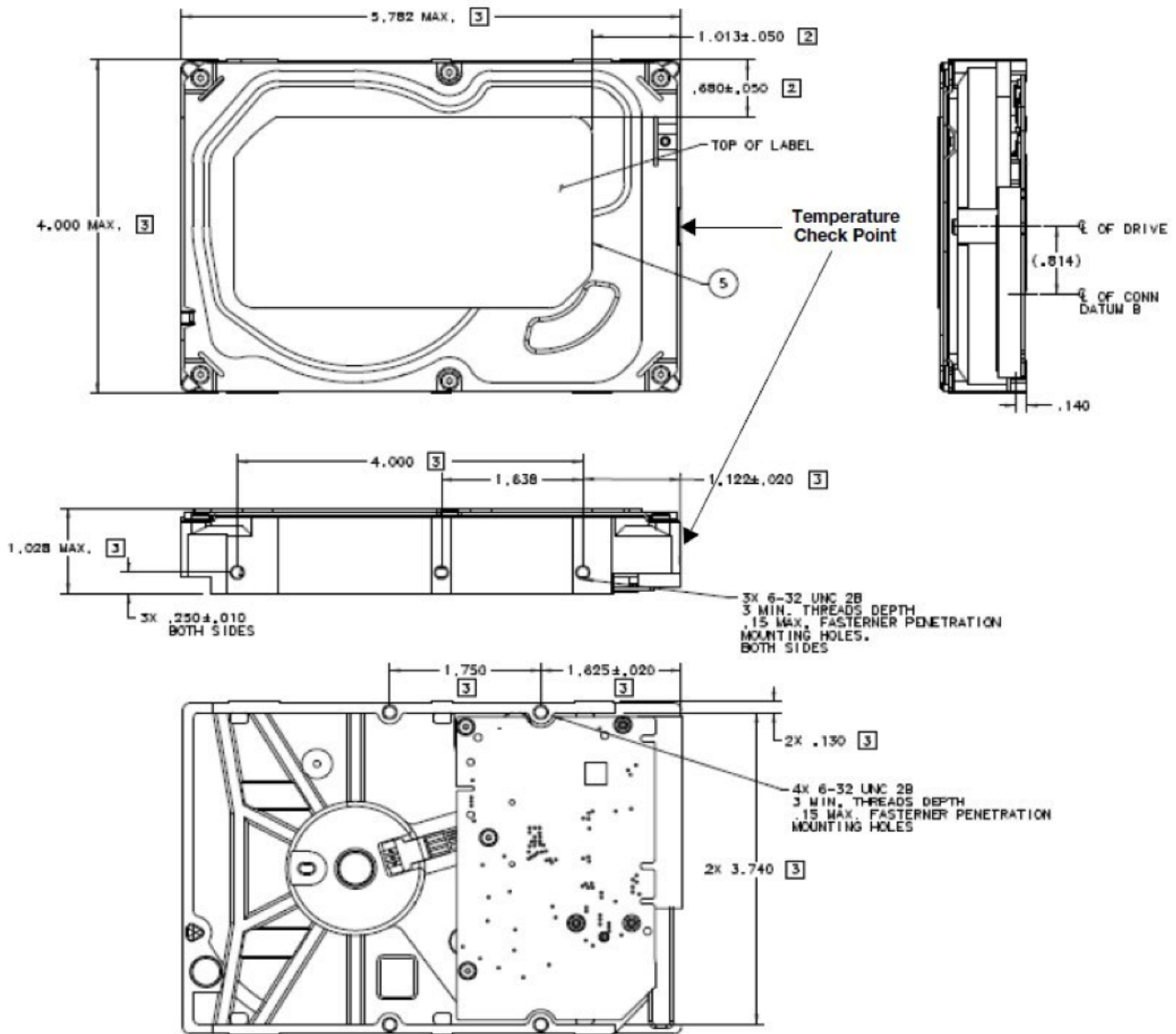

Figure 2 HDD Mounting Dimensions

Note PCBA may not be representative of the actual PCBA on drive.

3.3 DRIVE CONFIGURATIONS

When the Kinetic drives are connected to the local network with DHCP server, IP addresses will be self-assigned to each of the ports. Obtaining drive information, performing drive firmware updates, and other tools for drive configurations are provided in the Kinetic Python tools Github Repository: <https://github.com/Seagate/kinetic-py-tools>.

4.0 ETHERNET ENABLED INTERFACE

The Ethernet interface uses the standard SAS connector interface with repurposing of the pin outs. This section partially describes the interface requirements as implemented on Kinetic drives. The connector is defined by and conforms to the dimensions and specifications of SFF-8482 Rev 2.3.

4.1 SAS CONNECTOR PHYSICAL INTERFACE

Figures 4.1.1 and 4.1.2 provide the dimensions of the SAS connector. Details of the physical, electrical, and logical characteristics are provided within this section.

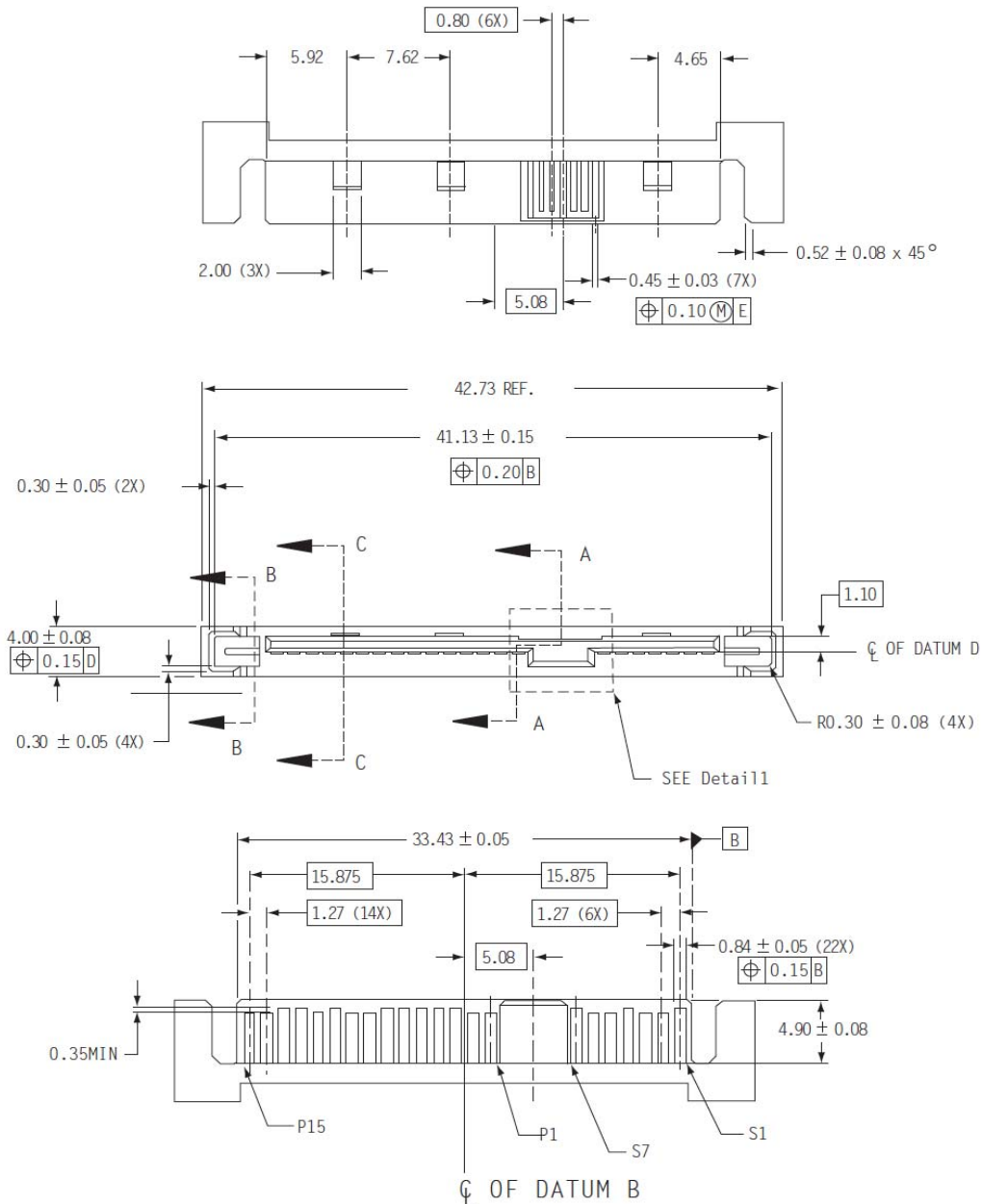

Figure 3 SAS Device Plug Dimensions

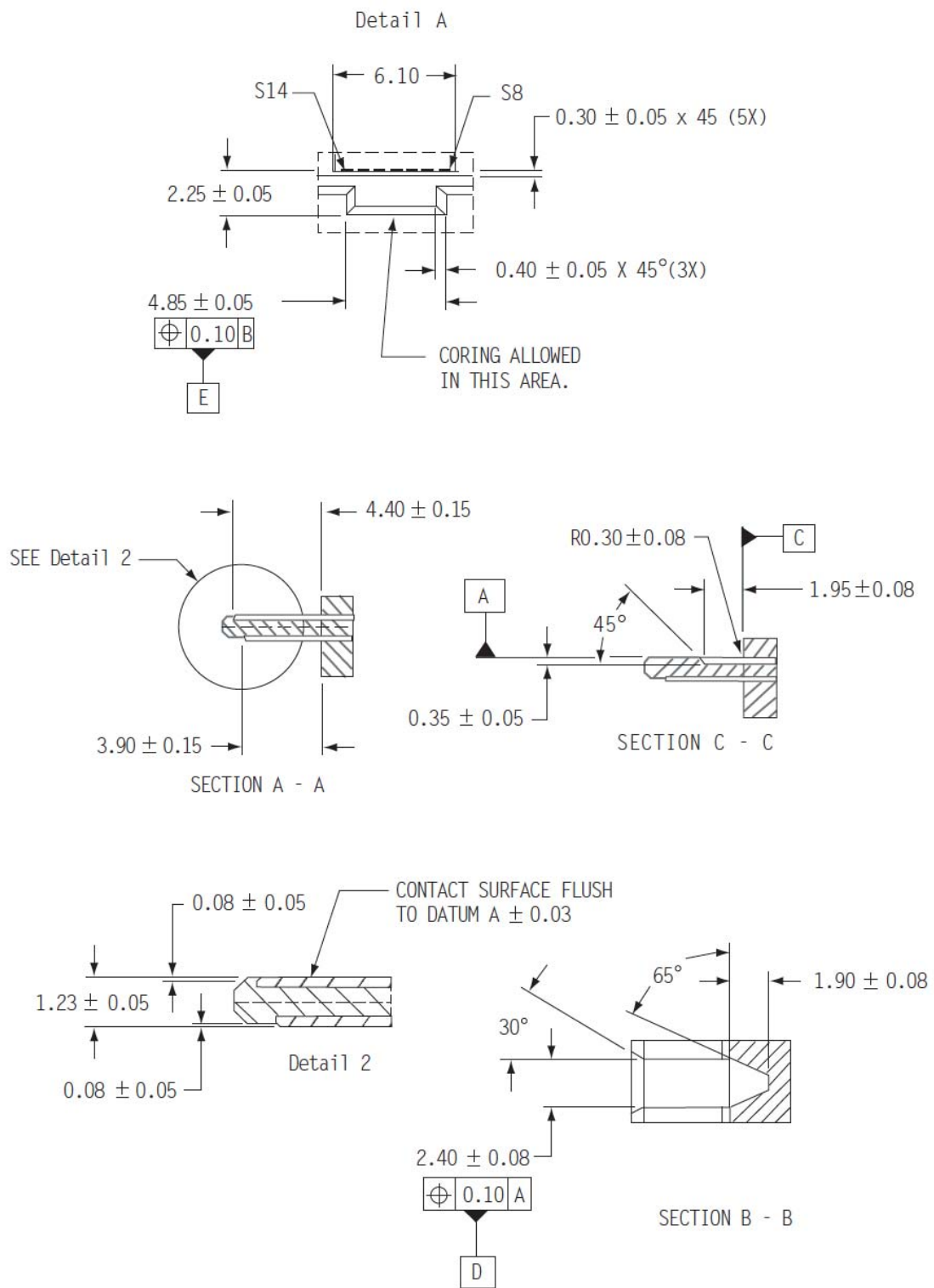

Figure 4 Detailed SAS Device Plug Dimensions

Figure 4.1.3 shows the pin locations for the SAS connector pin and Table 4.1.1 represents the Ethernet Enabled SAS Connector Pin Definitions for the Seagate Kinetic HDD.

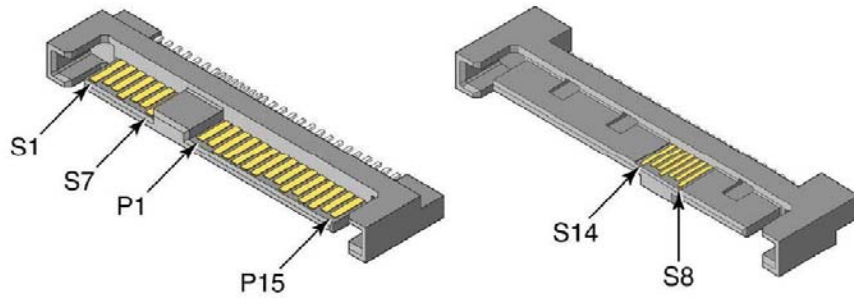

Figure 5 SAS Connector Pin Locations

Table 12: Ethernet Enabled SAS Connector Pin Definitions

Segment	Pin	Function	Comments
Signal	S1	GROUND	
	S2	RX0+	Ethernet port 0
	S3	RX0-	Ethernet port 0
	S4	GROUND	
	S5	TX0-	Ethernet port 0
	S6	TX0+	Ethernet port 0
	S7	GROUND	
	S8	GROUND	
	S9	RX1+	Ethernet port 1
	S10	RX1-	Ethernet port 1
	S11	GROUND	
	S12	TX1-	Ethernet port 1
	S13	TX1+	Ethernet port 1
	S14	GROUND	
Power	P1	RESERVED	Reserved for internal use. Do not connect. 3.3V tolerant.
	P2	I2C CLOCK	3.3V tolerant
	P3	I2C DATA	3.3V tolerant
	P4	GROUND	
	P5	GROUND	
	P6	GROUND	
	P7	+5V PRECHARGE	
	P8	+5V	
	P9	+5V	
	P10	GROUND	
	P11	RESERVED	Reserved for internal use. Do not connect.
	P12	GROUND	
	P13	+12V PRECHARGE	
	P14	+12V	
	P15	+12V	

Notes

- All pins are in a single row, with a 1.27 mm (0.050”) pitch.
- There are three power pins for each voltage.
One pin from each voltage is used for pre-charge when installed in a blind-mate backplane configuration.
- All used voltage pins must be terminated.

5.0 KEY/VALUE PROTOCOL

The protocol provides communication from the client applications to the Kinetic drive. The architecture for Kinetic storage is shown in Figure 5.1.

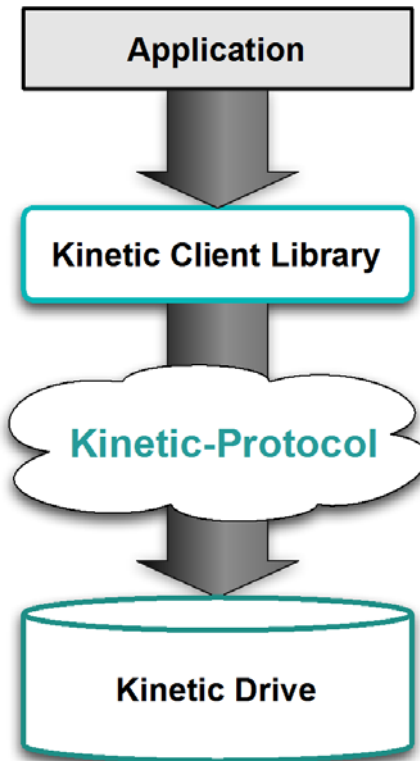

Figure 6 Kinetic Software Stack

This section explains the Kinetic Protocol Data Unit. For more information about the Kinetic Protocol, please visit: <https://github.com/Seagate/kinetic-protocol>.

5.1 HOST TO DRIVE DATA TRANSFER

Host to drive data transfer is accomplished using three basic commands:

- **put** – Add the specified key/value object to the store
- **get** – Retrieve the key/value object associated with the specified key
- **delete** – Delete the key/value object that is associated with the specified key.

In addition to the basic commands, other key/value object operations are also supported:

- **getNext** – Gets the key/value object associated with the key that follows the specified key based on the lexicographical ordering of keys
- **getPrevious** – Gets the key/value object associated with the key that precedes the specified key based on the lexicographical ordering of keys
- **getKeyRange** – Get a list of keys in lexicographical order based on the specified key range
- **getMetadata** – Get metadata for the specified key

Host applications communicate with the Kinetic drives by sending Kinetic Protocol Data Units over a network using TCP.

5.2 KINETIC PROTOCOL DATA UNIT

A Kinetic PDU is composed of five fields

1. PDU version
2. Kinetic Message length
3. value length
4. Kinetic Message
5. Value

Some PDUs have a null value. It is important to note that the value is not encoded in the Kinetic Message; it is a separate field of the Kinetic PDU.

Specifically, a Kinetic PDU structure is shown in Table 5.2.1.

Table 13: Kinetic PDU Structure

Starting Offset	Type	Length	Description
0	Byte	1 Byte	PDU version: currently hex 46, denoting the beginning of the message.
1	4-byte Big Endian Integer	4 Bytes	The number of bytes in the Kinetic Message field. The maximum length for a Kinetic Message is 1 MiB (2 ²⁰ bytes).
5	4-byte Big Endian Integer	4 Bytes	The number of bytes in the value field. The maximum length for a value is 1 MiB (2 ²⁰ bytes).
9	Bytes	<= 1 MiB	The Kinetic Message.
9 + length of Kinetic Message	Bytes	<= 1 MiB	The value.

Figure 5.2.1 shows a visual of how the Kinetic PDU is structured.



Figure 7 Kinetic Protocol Data Unit Message Packet

5.3 KINETIC MESSAGE

The syntax and encoding of Kinetic Message is defined using Google Protocol Buffers and is specified by the file kinetic.proto. The top-level message, Message, contains three embedded messages:

1. Messagetype
2. hmacAuth
3. command

5.4 COMMAND EMBEDDED MESSAGE

Command is transported as bytes for ease of calculating the HMAC.

The command bytes are interpreted by casting them as embedded message, Command, containing three embedded messages:

1. Header – Contains metadata about type of message command, such as PUT, GET, and DELETE operations.
2. Body – Contains operation-specific information, such as key range information used for the GETKEYRANGE operations.
3. Status – Contains information about whether an associated operation succeeded or failed.

This is shown graphically in Figure 5.4.1.

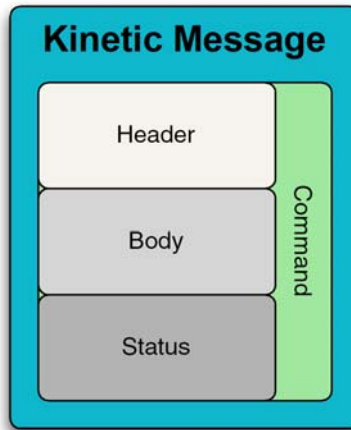

Figure 8 Command Embedded Message

As shown in Figure 5.4.1, the Header, Body, and Status messages are all members of the Command message.



Seagate Technology LLC

AMERICAS Seagate Technology LLC 10200 South De Anza Boulevard, Cupertino, California 95014, United States, 408-658-1000

ASIA/PACIFIC Seagate Singapore International Headquarters Pte. Ltd. 7000 Ang Mo Kio Avenue 5, Singapore 569877, 65-6485-3888

EUROPE, MIDDLE EAST AND AFRICA Seagate Technology SAS 16-18 rue du Dôme, 92100 Boulogne-Billancourt, France, 33 1-4186 10 00

*Publication Number: 100764174, Rev. A
October 2014*