

A decorative graphic on the left side of the page. It features a large dashed circle at the top left, a solid blue circle below it, and several overlapping curved lines that sweep from the top left towards the bottom right. A small solid blue circle is positioned above the top dashed circle.

Product Manual

Cheetah 15K.6 FC

ST3450856FC
ST3300656FC
ST3146356FC

100465943
Rev. A
October 2007

©2007, Seagate Technology LLC All rights reserved.
Publication number: 100465943, Rev. A
October 2007

Seagate, Seagate Technology and the Wave logo are registered trademarks of Seagate Technology LLC in the United States and/or other countries. Cheetah, SeaTools and SeaTDD are either trademarks or registered trademarks of Seagate Technology LLC or one of its affiliated companies in the United States and/or other countries. All other trademarks or registered trademarks are the property of their respective owners.

One gigabyte, or GB, equals one billion bytes when referring to hard drive capacity. Accessible capacity may vary depending on operating environment and formatting. Quantitative usage examples for various applications are for illustrative purposes. Actual quantities will vary based on various factors, including file size, file format, features and application software. Seagate reserves the right to change, without notice, product offerings or specifications.

Contents

1.0	Scope	1
2.0	Applicable standards and reference documentation	3
2.1	Standards	3
2.1.1	Electromagnetic compatibility	3
2.1.2	Electromagnetic compliance	4
2.2	European Union Restriction of Hazardous Substances (RoHS)	4
2.3	Reference documents	5
3.0	General description	7
3.1	Standard features	8
3.2	Media description	8
3.3	Performance	9
3.4	Reliability	9
3.5	Formatted capacities	9
3.5.1	Programmable drive capacity	9
3.6	Factory-installed options	9
3.7	User-installed accessories	10
4.0	Performance characteristics	11
4.1	Internal drive characteristics	11
4.2	Seek performance characteristics	11
4.2.1	Access time	11
4.2.2	Format command execution time (minutes)	12
4.2.3	General performance characteristics	12
4.3	Start/stop time	12
4.4	Prefetch/multi-segmented cache control	12
4.5	Cache operation	13
4.5.1	Caching write data	13
4.5.2	Prefetch operation	14
5.0	Reliability specifications	15
5.1	Error rates	15
5.1.1	Recoverable Errors	15
5.1.2	Unrecoverable Errors	15
5.1.3	Seek errors	16
5.1.4	Interface errors	16
5.2	Reliability and service	16
5.2.1	Annualized Failure Rate (AFR) and Mean Time Between Failures (MTBF)	16
5.2.2	Preventive maintenance	16
5.2.3	Hot plugging the drive	16
5.2.4	S.M.A.R.T.	17
5.2.5	Thermal monitor	18
5.2.6	Drive Self Test (DST)	19
5.2.7	Product warranty	21
6.0	Physical/electrical specifications	23
6.1	AC power requirements	23
6.2	DC power requirements	23
6.2.1	Conducted noise immunity	25
6.2.2	Power sequencing	25
6.2.3	Current profiles	25
6.3	Power dissipation	29
6.4	Environmental limits	31
6.4.1	Temperature	31

6.4.2	Relative humidity	32
6.4.3	Effective altitude (sea level)	32
6.4.4	Shock and vibration	32
6.4.5	Acoustics	35
6.4.6	Air cleanliness	35
6.4.7	Corrosive environment	35
6.4.8	RoHS compliance statement	36
6.4.9	Electromagnetic susceptibility	36
6.5	Mechanical specifications	37
7.0	Defect and error management	39
7.1	Drive internal defects/errors	39
7.2	Drive error recovery procedures	39
7.3	FC-AL system errors	41
7.4	Background Media Scan	41
7.5	Media Pre-Scan	42
7.6	Deferred Auto-Reallocation	42
7.7	Idle Read After Write	43
8.0	Installation	45
8.1	Drive ID/option selection	45
8.2	Drive orientation	45
8.3	Cooling	45
8.4	Drive mounting	46
8.5	Grounding	47
9.0	Interface requirements	49
9.1	FC-AL features	49
9.1.1	Fibre Channel link service frames	49
9.1.2	Fibre Channel task management functions	50
9.1.3	Fibre Channel task management responses	50
9.1.4	Fibre Channel port login	51
9.1.5	Fibre Channel port login accept	52
9.1.6	Fibre Channel Process Login	52
9.1.7	Fibre Channel Process Login Accept	53
9.1.8	Fibre Channel fabric login	53
9.1.9	Fibre Channel fabric accept login	54
9.1.10	Fibre Channel Arbitrated Loop options	55
9.2	Dual port support	55
9.3	SCSI commands supported	56
9.3.1	Inquiry data	60
9.3.2	Mode Sense data	60
9.4	Miscellaneous operating features and conditions	65
9.5	FC-AL physical interface	66
9.5.1	Physical characteristics	66
9.5.2	Connector requirements	67
9.5.3	Electrical description	67
9.5.4	Pin descriptions	67
9.5.5	FC-AL transmitters and receivers	68
9.5.6	Power	69
9.5.7	Fault LED Out	69
9.5.8	Active LED Out	70
9.5.9	Enable port bypass signals	70
9.5.10	Motor start controls	70
9.5.11	SEL_6 through SEL_0 ID lines	71
9.5.12	Device control codes	73

9.6	Signal characteristics	73
9.6.1	TTL input characteristics	73
9.6.2	LED driver signals	74
9.6.3	FC Differential output	74
9.6.4	FC Differential input	74
10.0	Seagate Technology support services	77

List of Figures

Figure 1.	Typical ST3300656FC current profiles	27
Figure 2.	Typical ST3146356FC current profiles	28
Figure 3.	ST3450856FC DC current and power vs. input/output operations per second at 4 Gbit	29
Figure 4.	ST3300656FC DC current and power vs. input/output operations per second at 4 Gbit	30
Figure 5.	ST3146356FC DC current and power vs. input/output operations per second at 4 Gbit	31
Figure 6.	Locations of the HDA temperature check point	32
Figure 7.	Recommended mounting	34
Figure 8.	Mounting configuration dimensions	37
Figure 9.	Air flow	46
Figure 10.	Physical interface	66
Figure 11.	Port bypass circuit physical interconnect	66
Figure 12.	FC-AL SCA device connector dimensions	67
Figure 13.	FC-AL transmitters and receivers	68
Figure 14.	Transmit eye diagram	74
Figure 15.	Receive eye diagram	75

1.0 Scope

This manual describes Seagate Technology® LLC, Cheetah® 15K.6 FC (Fibre Channel) disc drives.

Cheetah 15K.6 FC drives support the Fibre Channel Arbitrated Loop and SCSI Fibre Channel Protocol specifications to the extent described in this manual. The *Fibre Channel Interface Manual* (part number 100293070) describes the general Fibre Channel Arbitrated Loop characteristics of this and other Seagate Fibre Channel drives.

From this point on in this product manual, the reference to Cheetah 15K.6 FC models is referred to as “the drive” unless references to individual models are necessary.

2.0 Applicable standards and reference documentation

The drive has been developed as a system peripheral to the highest standards of design and construction. The drive depends upon its host equipment to provide adequate power and environment in order to achieve optimum performance and compliance with applicable industry and governmental regulations. Special attention must be given in the areas of safety, power distribution, shielding, audible noise control, and temperature regulation. In particular, the drive must be securely mounted in order to guarantee the specified performance characteristics. Mounting by bottom holes must meet the requirements of Section 8.4.

2.1 Standards

The Cheetah 15K.6 FC family complies with Seagate standards as noted in the appropriate sections of this manual and the Seagate *Fibre Channel Interface Manual*, part number 100293070.

The Cheetah 15K.6 FC disc drive is a UL recognized component per UL1950, CSA certified to CAN/CSA C22.2 No. 950-95, and VDE certified to VDE 0805 and EN60950.

2.1.1 Electromagnetic compatibility

The drive, as delivered, is designed for system integration and installation into a suitable enclosure prior to use. As such the drive is supplied as a subassembly and is not subject to Subpart B of Part 15 of the FCC Rules and Regulations nor the Radio Interference Regulations of the Canadian Department of Communications.

The design characteristics of the drive serve to minimize radiation when installed in an enclosure that provides reasonable shielding. As such, the drive is capable of meeting the Class B limits of the FCC Rules and Regulations of the Canadian Department of Communications when properly packaged. However, it is the user's responsibility to assure that the drive meets the appropriate EMI requirements in their system. Shielded I/O cables may be required if the enclosure does not provide adequate shielding. If the I/O cables are external to the enclosure, shielded cables should be used, with the shields grounded to the enclosure and to the host controller.

2.1.1.1 Electromagnetic susceptibility

As a component assembly, the drive is not required to meet any susceptibility performance requirements. It is the responsibility of those integrating the drive within their systems to perform those tests required and design their system to ensure that equipment operating in the same system as the drive or external to the system does not adversely affect the performance of the drive. See Table 2, DC power requirements.

2.1.2 Electromagnetic compliance

Seagate uses an independent laboratory to confirm compliance with the directives/standards for CE Marking and C-Tick Marking. The drive was tested in a representative system for typical applications. The selected system represents the most popular characteristics for test platforms. The system configurations include:

- Typical current use microprocessor
- Keyboard
- Monitor/display
- Printer
- Mouse

Although the test system with this Seagate model complies with the directives/standards, we cannot guarantee that all systems will comply. The computer manufacturer or system integrator shall confirm EMC compliance and provide the appropriate marking for their product.

Electromagnetic compliance for the European Union

If this model has the CE Marking it complies with the European Union requirements of the Electromagnetic Compatibility Directive 89/336/EEC of 03 May 1989 as amended by Directive 92/31/EEC of 28 April 1992 and Directive 93/68/EEC of 22 July 1993.

Australian C-Tick

If this model has the C-Tick Marking it complies with the Australia/New Zealand Standard AS/NZS3548 1995 and meets the Electromagnetic Compatibility (EMC) Framework requirements of Australia's Spectrum Management Agency (SMA).

Korean MIC

If this model has the Korean Ministry of Information and Communication (MIC) logo, it complies with paragraph 1 of Article 11 of the Electromagnetic Compatibility (EMC) Control Regulation and meets the Electromagnetic Compatibility Framework requirements of the Radio Research Laboratory (RRL) Ministry of Information and Communication Republic of Korea.

This drive has been tested and complies with the Electromagnetic Interference/Electromagnetic Susceptibility (EMI/EMS) for Class B products.

Taiwanese BSMI

If this model has the Chinese National Standard (CNS) 13438 marking, it complies with Chinese National Standard (CNS) 13438 and meets the Electromagnetic Compatibility (EMC) Framework requirements of the Taiwanese Bureau of Standards, Metrology, and Inspection (BSMI).

2.2 European Union Restriction of Hazardous Substances (RoHS)

The European Union Restriction of Hazardous Substances (RoHS) Directive restricts the presence of chemical substances, including Lead (Pb), in electronic products effective July 2006.

A number of parts and materials in Seagate products are procured from external suppliers. We rely on the representations of our suppliers regarding the presence of RoHS substances in these parts and materials. Our supplier contracts require compliance with our chemical substance restrictions, and our suppliers document their compliance with our requirements by providing material content declarations for all parts and materials for the disc drives documented in this publication. Current supplier declarations include disclosure of the inclusion of any RoHS-regulated substance in such parts or materials.

Seagate also has internal systems in place to ensure ongoing compliance with the RoHS Directive and all laws and regulations which restrict chemical content in electronic products. These systems include standard operating procedures that ensure that restricted substances are not utilized in our manufacturing operations, laboratory analytical validation testing, and an internal auditing process to ensure that all standard operating procedures are complied with.

2.3 Reference documents

ANSI Fibre Channel Documents

X3.230-1994	FC Physical and Signaling Interface (FC-PH)
X3.297.1997	FC-PH-2 Fibre Channel Physical and Signaling Interface-2
X3.303.1998	FC-PH-3 Fibre Channel Physical and Signaling Interface-3
X3.272-1996	FC Arbitrated Loop (FC-AL)
X3.269-1996	Fibre Channel Protocol for SCSI (FCP)
NCITS TR-19	Private Loop SCSI Direct Attach (PLDA)
NCITS TR-20	Fabric Loop Attachment (FC-FLA)
SFF-8045	Specification for 40-pin SCA-2 Connector with Parallel Selection
SFF-8067	Specification for 40-pin SCA-2 Connector with Bidirectional Enclosure Services Interface

ANSI Small Computer System Interface (SCSI) Documents

X3.131-1994	(SCSI-2)
X3.270-1996	(SCSI-3) Architecture Model
NCITS 305-199X	(SCSI-3) Enclosure Services

Specification for Acoustic Test Requirement and Procedures

Seagate part number: 30553-001

Package Test Specification	Seagate P/N 30190-001 (under 100 lb.)
Package Test Specification	Seagate P/N 30191-001 (over 100 lb.)

In case of conflict between this document and any referenced document, this document takes precedence.

3.0 General description

Cheetah 15K.6 FC drives provide high performance, high capacity data storage for a variety of systems including engineering workstations, network servers, mainframes, and supercomputers. Cheetah 15K.6 FC drives support 4-Gbit Fibre Channel.

Cheetah 15K.6 FC drives support the Fibre Channel Arbitrated Loop (FC-AL) and SCSI Fibre Channel Protocol as described in the ANSI specifications, this document, and the *Fibre Channel Interface Manual* which describes the general interface characteristics of this drive. Cheetah 15K.6 FC drives are classified as intelligent peripherals and provide level 2 conformance (highest level) with the ANSI SCSI-1 standard.

Never disassemble the HDA and do not attempt to service items in the sealed enclosure (heads, media, actuator, etc.) as this requires special facilities. The drive does not contain user-replaceable parts. Opening the HDA for any reason voids your warranty.

Cheetah 15K.6 FC drives use a dedicated landing zone at the innermost radius of the media to eliminate the possibility of destroying or degrading data by landing in the data zone. The heads automatically go to the landing zone when power is removed from the drive.

An automatic shipping lock prevents potential damage to the heads and discs that results from movement during shipping and handling. The shipping lock disengages and the head load process begins when power is applied to the drive.

The drives also use a high-performance actuator assembly with a low-inertia, balanced, patented, straight arm design that provides excellent performance with minimal power dissipation.

3.1 Standard features

Cheetah 15K.6 FC drives have the following standard features:

- Perpendicular recording technology
- 4-Gbit Fibre Channel interface
- Integrated dual port FC-AL controller
- Concurrent dual port transfers
- Support for FC arbitrated loop, private and public attachment
- Differential copper FC drivers and receivers
- Downloadable firmware using the FC-AL interface
- Supports SCSI enclosure services via interface connector
- 128-deep task set (queue)
- Supports up to 32 initiators
- Drive selection ID and configuration options are set on the FC-AL backpanel or through interface commands. Jumpers are not used on the drive.
- Supports SCSI Enclosure Services through the interface connector
- Fibre Channel worldwide name uniquely identifies the drive and each port
- User-selectable logical block size (512, 520, 524, or 528 bytes per logical block)
- Selectable frame sizes from 256 to 2,112 bytes
- Industry standard 3.5-inch low profile form factor dimensions
- Programmable logical block reallocation scheme
- Flawed logical block reallocation at format time
- Programmable auto write and read reallocation
- Reed-Solomon error correction code
- Sealed head and disc assembly (HDA)
- No preventive maintenance or adjustments required
- Dedicated head landing zone
- Automatic shipping lock
- Embedded Grey Code track address to eliminate seek errors
- Self-diagnostics performed at power on
- Zone bit recording (ZBR)
- Vertical, horizontal, or top down mounting
- Dynamic spindle brake
- 16,384 Kbyte data buffer (see Section 4.5).
- Embedded servo design
- Reallocation of defects on command (Post Format)
- Fibre Channel interface transports SCSI protocol

3.2 Media description

The media used on the drive has an aluminum substrate coated with a thin film magnetic material, overcoated with a proprietary protective layer for improved durability and environmental protection.

3.3 Performance

- Programmable multi-segmentable cache buffer
- 800 Mbytes/sec maximum instantaneous data transfers per port
- 15k RPM spindle; average latency = 2.0 msec
- Command queuing of up to 128 commands
- Background processing of queue
- Supports start and stop commands (spindle stops spinning)
- Adaptive seek velocity; improved seek performance

3.4 Reliability

- Annualized Failure Rate (AFR) of 0.55%
- Increased LSI circuitry integration
- Self-Monitoring Analysis and Reporting Technology (S.M.A.R.T.)
- Dithering
- 5-year warranty

3.5 Formatted capacities

Standard OEM models are formatted to 512 bytes per block. The block size is selectable at format time and must be one of the supported sizes listed in the table below.

Seagate designs specify capacity points at certain block sizes that Seagate guarantees current and future products will meet. We recommend customers use this capacity in their project planning, as it ensures a stable operating point with backward and forward compatibility from generation to generation. The current guaranteed operating points for this product are:

Sector Size	ST3450856FC		ST3300656FC		ST3146356FC	
	Decimal	Hex	Decimal	Hex	Decimal	Hex
512	879,097,968	3465F870	585,937,500	22ECB25C	286,749,488	11177330
520	860,480,771	3349E503	573,653,848	22314358	280,790,185	10BC84A9
524	849,011,700	329AE3F4	566,007,800	21BC97F8	275,154,368	106685C0
528	836,812,167	31E0BD87	557,874,778	21407E5A	272,662,935	10408197

3.5.1 Programmable drive capacity

Using the Mode Select command, the drive can change its capacity to something less than maximum. See the Mode Select Parameter List table in the *SCSI Commands Reference Manual*. Refer to the Parameter list block descriptor number of blocks field. A value of zero in the number of blocks field indicates that the drive shall not change the capacity it is currently formatted to have. A number in the number of blocks field that is less than the maximum number of LBAs changes the total drive capacity to the value in the block descriptor number of blocks field. A value greater than the maximum number of LBAs is rounded down to the maximum capacity.

3.6 Factory-installed options

You may order the following items which are incorporated at the manufacturing facility during production or packaged before shipping. Some of the options available are (not an exhaustive list of possible options):

- Other capacities can be ordered depending on sparing scheme and sector size requested.

- Single-unit shipping pack. The drive is normally shipped in bulk packaging to provide maximum protection against transit damage. Units shipped individually require additional protection as provided by the single unit shipping pack. Users planning single unit distribution should specify this option.
- The *Safety and Regulatory Agency Specifications*, part number 75789512, is usually included with each standard OEM drive shipped, but extra copies may be ordered.

3.7 User-installed accessories

The following accessories are available. All kits may be installed in the field.

- Evaluation kit, part number 73473641.
This kit provides an adapter card (“T-card”) to allow cable connections for two FC ports and DC power.
- Single-unit shipping pack.

4.0 Performance characteristics

This section provides detailed information concerning performance-related characteristics and features of Cheetah 15K.6 FC drives.

4.1 Internal drive characteristics

	ST3450856FC	ST3300656FC	ST3146356FC	
Drive capacity*	450	300	146	Gbytes (formatted, rounded off value)
Read/write data heads	8	6	3	
Tracks per inch	150,000	150,000	150,000	TPI
Peak bits per inch	1,100k	1,100k	1,100k	BPI
Areal density	165	165	165	Gbits/inch ²
Internal data rate	1.95	1.95	1.95	Gbits/sec (max)
Disc rotation speed	15k	15k	15k	rpm
Avg rotational latency	2.0	2.0	2.0	msec

*One Gbyte equals one billion bytes when referring to hard drive capacity. Accessible capacity may vary depending on operating environment and formatting.

4.2 Seek performance characteristics

See Section 9.5, "FC-AL physical interface" on page 66 and the *Fibre Channel Interface Manual* (part number 77767496) for additional timing details.

4.2.1 Access time

		Not including controller overhead ^{1,2} (msec)	
		Read	Write
Average	Typical	3.4	3.9
Single track	Typical	0.20	0.44
Full stroke	Typical	6.43	7.12

1. Typical access times are measured under nominal conditions of temperature, voltage, and horizontal orientation as measured on a representative sample of drives.
2. Access to data = **access time** + latency time.

4.2.2 Format command execution time (minutes)

	ST3450856FC	ST3300656FC	ST3146356FC
Maximum (with verify)	176	144	100
Maximum (without verify)	88	72	50

4.2.3 General performance characteristics

Sustainable disc transfer rate*:

Minimum	112 Mbytes/sec (typical)
Maximum	171 Mbytes/sec (typical)

Fibre Channel Interface maximum instantaneous transfer rate 800 Mbytes/sec* per port

Logical block sizes

Default is 512-byte data blocks
Sector sizes variable to 512, 520, 524 and 528 bytes.

Read/write consecutive sectors on a track Yes

Flaw reallocation performance impact (for flaws reallocated at format time using the spare sectors per sparing zone reallocation scheme.) Negligible

Average rotational latency 2.0 msec

*Assumes no errors and no relocated logical blocks.

Rate measured from the start of the first logical block transfer to or from the host.

1MB/sec = 1,000,000 bytes/sec

4.3 Start/stop time

If the Motor Start option is disabled, the drive becomes ready within 20 seconds after DC power is applied. If a recoverable error condition is detected during the start sequence, the drive executes a recovery procedure and the time to become ready may exceed 20 seconds. During spin up to ready time, the drive responds to some commands over the FC interface in less than 3 seconds after application of power. Stop time is 30 seconds (maximum) from removal of DC power.

If the Motor Start option is enabled, the internal controller accepts the commands listed in the *Fibre Channel Interface Manual* less than 3 seconds after DC power has been applied. After the Motor Start command has been received, the drive becomes ready for normal operations within 20 seconds (excluding the error recovery procedure). The Motor Start command can also be used to command the drive to stop the spindle.

There is no power control switch on the drive.

4.4 Prefetch/multi-segmented cache control

The drive provides a prefetch (read look-ahead) and multi-segmented cache control algorithms that in many cases can enhance system performance. Cache refers to the drive buffer storage space when it is used in cache operations. To select this feature, the host sends the Mode Select command with the proper values in

the applicable bytes in page 08h. Prefetch and cache operations are independent features from the standpoint that each is enabled and disabled independently using the Mode Select command; however, in actual operation, the prefetch feature overlaps cache operation somewhat as described in sections 4.5.1 and 4.5.2.

All default cache and prefetch mode parameter values (Mode Page 08h) for standard OEM versions of this drive family are given in Table 18.

4.5 Cache operation

Note. Refer to the *Fibre Channel Interface Manual* for more detail concerning the cache bits.

Of the 16 Mbytes physical buffer space in the drive, approximately 13,000 kbytes can be used as a cache. The buffer is divided into logical segments from which data is read and to which data is written.

The drive keeps track of the logical block addresses of the data stored in each segment of the buffer. If the cache is enabled (see RCD bit in the *FC Interface Manual*), data requested by the host with a read command is retrieved from the buffer, if possible, before any disc access is initiated. If cache operation is not enabled, the buffer is still used, but only as circular buffer segments during disc medium read operations (disregarding Prefetch operation for the moment). That is, the drive does not check in the buffer segments for the requested read data, but goes directly to the medium to retrieve it. The retrieved data merely passes through some buffer segment on the way to the host. All data transfers to the host are in accordance with buffer-full ratio rules. See the explanation provided with the information about Mode Page 02h (disconnect/reconnect control) in the *Fibre Channel Interface Manual*.

The following is a simplified description of the prefetch/cache operation:

Case A—read command is received and all of the requested logical blocks are already in the cache:

1. Drive transfers the requested logical blocks to the initiator.

Case B—A Read command requests data, and at least one requested logical block is not in any segment of the cache:

1. The drive fetches the requested logical blocks from the disc and transfers them into a segment, and then from there to the host in accordance with the Mode Select Disconnect/Reconnect parameters, page 02h.
2. If the prefetch feature is enabled, refer to section 4.5.2 for operation from this point.

Each cache segment is actually a self-contained circular buffer whose length is an integer number of logical blocks. The drive dynamically creates and removes segments based on the workload. The wrap-around capability of the individual segments greatly enhances the cache's overall performance.

Note. The size of each segment is not reported by Mode Sense command page 08h, bytes 14 and 15. The value 0XFFFF is always reported regardless of the actual size of the segment. Sending a size specification using the Mode Select command (bytes 14 and 15) does not set up a new segment size. If the STRICT bit in Mode page 00h (byte 2, bit 1) is set to one, the drive responds as it does for any attempt to change an unchangeable parameter.

4.5.1 Caching write data

Write caching is a write operation by the drive that makes use of a drive buffer storage area where the data to be written to the medium is stored while the drive performs the Write command.

If read caching is enabled (RCD=0), then data written to the medium is retained in the cache to be made available for future read cache hits. The same buffer space and segmentation is used as set up for read functions. The buffer segmentation scheme is set up or changed independently, having nothing to do with the state of RCD. When a write command is issued, if RCD=0, the cache is first checked to see if any logical blocks that are to be written are already stored in the cache from a previous read or write command. If there are, the respective cache segments are cleared. The new data is cached for subsequent Read commands.

If the number of write data logical blocks exceed the size of the segment being written into, when the end of the segment is reached, the data is written into the beginning of the same cache segment, overwriting the data that was written there at the beginning of the operation; however, the drive does not overwrite data that has not yet been written to the medium.

If write caching is enabled (WCE=1), then the drive may return Good status on a write command after the data has been transferred into the cache, but before the data has been written to the medium. If an error occurs while writing the data to the medium, and Good status has already been returned, a deferred error will be generated.

The Synchronize Cache command may be used to force the drive to write all cached write data to the medium. Upon completion of a Synchronize Cache command, all data received from previous write commands will have been written to the medium.

Table 18 shows the mode default settings for the drive.

4.5.2 Prefetch operation

If the Prefetch feature is enabled, data in contiguous logical blocks on the disc immediately beyond that which was requested by a Read command are retrieved and stored in the buffer for immediate transfer from the buffer to the host on subsequent Read commands that request those logical blocks (this is true even if cache operation is disabled). Though the prefetch operation uses the buffer as a cache, finding the requested data in the buffer is a prefetch hit, not a cache operation hit.

To enable Prefetch, use Mode Select page 08h, byte 12, bit 5 (Disable Read Ahead - DRA bit). DRA bit = 0 enables prefetch.

The drive does not use the Max Prefetch field (bytes 8 and 9) or the Prefetch Ceiling field (bytes 10 and 11).

When prefetch (read look-ahead) is enabled (enabled by DRA = 0), the drive enables prefetch of contiguous blocks from the disc when it senses that a prefetch hit will likely occur. The drive disables prefetch when it decides that a prefetch hit is not likely to occur.

5.0 Reliability specifications

The following reliability specifications assume correct host and drive operational interface, including all interface timings, power supply voltages, environmental requirements and drive mounting constraints.

Seek error rate:	Less than 10 errors in 10^8 seeks
Read Error Rates	
Recovered Data	Less than 10 errors in 10^{12} bits transferred (OEM default settings)
Unrecovered Data	Less than 1 sector in 10^{16} bits transferred
Miscorrected Data	Less than 1 sector in 10^{21} bits transferred
Interface error rate:	Less than 1 error in 10^{12} bits transferred with minimum receive eye. Less than 1 error in 10^{14} bits transferred with typical receive eye. See Section 9.6.4, "FC Differential input." on page 74
Annualized Failure Rate (AFR):	0.55%
Preventive maintenance:	None required

5.1 Error rates

The error rates stated in this manual assume the following:

- The drive is operated in accordance with this manual using DC power as defined in paragraph 6.2, "DC power requirements."
- Errors caused by host system failures are excluded from error rate computations.
- Assume random data.
- Default OEM error recovery settings are applied. This includes AWRE, ARRE, full read retries, full write retries and full retry time.
- Error rate specified with automatic retries and data correction with ECC enabled and all flaws reallocated.

5.1.1 Recoverable Errors

Recoverable errors are those detected and corrected by the drive, and do not require user intervention.

Recoverable Data errors use retries and correction. Application of ECC on-the-fly correction alone is not considered a Recovered Data error.

Recovered Data error rate is determined using read bits transferred for recoverable errors occurring during a read, and using write bits transferred for recoverable errors occurring during a write.

5.1.2 Unrecoverable Errors

Unrecoverable Data Errors (Sense Key = 03h) are specified at less than 1 sector in error per 10^{16} bits transferred. Unrecoverable Data Errors resulting from the same cause are treated as 1 error for that block.

5.1.3 Seek errors

A seek error is defined as a failure of the drive to position the heads to the addressed track. After detecting an initial seek error, the drive automatically performs an error recovery process. If the error recovery process fails, a seek positioning error (Error code = 15h or 02h) will be reported with a Hardware error (04h) in the Sense Key. Recoverable seek errors are specified at Less than 10 errors in 10^8 seeks. Unrecoverable seek errors (Sense Key = 04h) are classified as drive failures.

5.1.4 Interface errors

An interface error is defined as a failure of the receiver on a port to recover the data as transmitted by the device port connected to the receiver. The error may be detected as a running disparity error, illegal code, loss of word sync, or CRC error. The total error rate for a loop of devices is the sum of the individual device error rates.

5.2 Reliability and service

You can enhance the reliability of Cheetah 15K.6 disc drives by ensuring that the drive receives adequate cooling. Section 6.0 provides temperature measurements and other information that may be used to enhance the service life of the drive. Section 8.2 provides recommended air-flow information.

5.2.1 Annualized Failure Rate (AFR) and Mean Time Between Failures (MTBF)

These drives shall achieve an AFR of 0.55% (MTBF of 1,600,000 hours) when operated in an environment that ensures the HDA case temperatures do not exceed the values specified in Section 6.4.1.

Operation at case temperatures outside the specifications in Section 6.4.1 may increase the AFR (decrease the MTBF). AFR and MTBF statistics are population statistics that are not relevant to individual units.

AFR and MTBF specifications are based on the following assumptions for Enterprise Storage System environments:

- 8,760 power-on hours per year
- 250 average on/off cycles per year
- Operating at nominal voltages
- System provides adequate cooling to ensure the case temperatures specified in Section 6.4.1 are not exceeded.

5.2.2 Preventive maintenance

No routine scheduled preventive maintenance is required.

5.2.3 Hot plugging the drive

Inserting and removing the drive on the FC-AL will interrupt loop operation. The interruption occurs when the receiver of the next device in the loop must synchronize to a different input signal. FC error detection mechanisms, character sync, running disparity, word sync, and CRC are able to detect any error. Recovery is initiated based on the type of error.

The disc drive defaults to the FC-AL Monitoring state, Pass-through state, when it is powered-on by switching the power or hot plugged. The control line to an optional port bypass circuit (external to the drive), defaults to the Enable Bypass state. If the bypass circuit is present, the next device in the loop will continue to receive the output of the previous device to the newly inserted device. If the bypass circuit is not present, loop operation is temporarily disrupted until the next device starts receiving the output from the newly inserted device and regains synchronization to the new input.

The Pass-through state is disabled while the drive performs self test of the FC interface. The control line for an external port bypass circuit remains in the Enable Bypass state while self test is running. If the bypass circuit is present, loop operation may continue. If the bypass circuit is not present, loop operation will be halted while the self test of the FC interface runs.

When the self test completes successfully, the control line to the bypass circuit is disabled and the drive enters the FC-AL Initializing state. The receiver on the next device in the loop must synchronize to output of the newly inserted drive.

If the self-test fails, the control line to the bypass circuit remains in the Enable Bypass state.

Note. It is the responsibility of the systems integrator to assure that no temperature, energy, voltage hazard, or ESD potential hazard is presented during the hot connect/disconnect operation. Discharge the static electricity from the drive carrier prior to inserting it into the system.

Caution. The drive motor must come to a complete stop prior to changing the plane of operation. This time is required to insure data integrity.

5.2.4 S.M.A.R.T.

S.M.A.R.T. is an acronym for Self-Monitoring Analysis and Reporting Technology. This technology is intended to recognize conditions that indicate imminent drive failure and is designed to provide sufficient warning of a failure to allow you to back up the data before an actual failure occurs.

Note. The drive's firmware monitors specific attributes for degradation over time but can't predict instantaneous drive failures.

Each monitored attribute has been selected to monitor a specific set of failure conditions in the operating performance of the drive and the thresholds are optimized to minimize "false" and "failed" predictions.

Controlling S.M.A.R.T.

The operating mode of S.M.A.R.T. is controlled by the DEXCPT and PERF bits on the Informational Exceptions Control mode page (1Ch). Use the DEXCPT bit to enable or disable the S.M.A.R.T. feature. Setting the DEXCPT bit disables all S.M.A.R.T. functions. When enabled, S.M.A.R.T. collects on-line data as the drive performs normal read and write operations. When the PERF bit is set, the drive is considered to be in "On-line Mode Only" and will not perform off-line functions.

You can measure off-line attributes and force the drive to save the data by using the Rezero Unit command. Forcing S.M.A.R.T. resets the timer so that the next scheduled interrupt is in two hours.

You can interrogate the drive through the host to determine the time remaining before the next scheduled measurement and data logging process occurs. To accomplish this, issue a Log Sense command to log page 0x3E. This allows you to control when S.M.A.R.T. interruptions occur. Forcing S.M.A.R.T. with the RTZ command resets the timer.

Performance impact

S.M.A.R.T. attribute data is saved to the disc so that the events that caused a predictive failure can be recreated. The drive measures and saves parameters once every two hours subject to an idle period on the FC-AL bus. The process of measuring off-line attribute data and saving data to the disc is uninterruptable. The maximum on-line only processing delay is summarized below:

Maximum processing delay

	On-line only delay DEXCPT = 0, PERF = 1	Fully-enabled delay DEXCPT = 0, PERF = 0
S.M.A.R.T. delay times	42 milliseconds	163 milliseconds

Reporting control

Reporting is controlled by the MRIE bits in the Informational Exceptions Control mode page (1Ch). Subject to the reporting method, the firmware will issue to the host an 01-5Dxx sense code. The error code is preserved through bus resets and power cycles.

Determining rate

S.M.A.R.T. monitors the rate at which errors occur and signals a predictive failure if the rate of degraded errors increases to an unacceptable level. To determine rate, error events are logged and compared to the number of total operations for a given attribute. The interval defines the number of operations over which to measure the rate. The counter that keeps track of the current number of operations is referred to as the Interval Counter.

S.M.A.R.T. measures error rates. All errors for each monitored attribute are recorded. A counter keeps track of the number of errors for the current interval. This counter is referred to as the Failure Counter.

Error rate is the number of errors per operation. The algorithm that S.M.A.R.T. uses to record rates of error is to set thresholds for the number of errors and their interval. If the number of errors exceeds the threshold before the interval expires, the error rate is considered to be unacceptable. If the number of errors does not exceed the threshold before the interval expires, the error rate is considered to be acceptable. In either case, the interval and failure counters are reset and the process starts over.

Predictive failures

S.M.A.R.T. signals predictive failures when the drive is performing unacceptably for a period of time. The firmware keeps a running count of the number of times the error rate for each attribute is unacceptable. To accomplish this, a counter is incremented each time the error rate is unacceptable and decremented (not to exceed zero) whenever the error rate is acceptable. If the counter continually increments such that it reaches the predictive threshold, a predictive failure is signaled. This counter is referred to as the Failure History Counter. There is a separate Failure History Counter for each attribute.

5.2.5 Thermal monitor

Cheetah 15K.6 FC drives implement a temperature warning system which:

1. Signals the host if the temperature exceeds a value which would threaten the drive.
2. Signals the host if the temperature exceeds a user-specified value.
3. Saves a S.M.A.R.T. data frame on the drive which exceeds the threatening temperature value.

A temperature sensor monitors the drive temperature and issues a warning over the interface when the temperature exceeds a set threshold. The temperature is measured at power-up and then at ten-minute intervals after power-up.

The thermal monitor system generates a warning code of 01-0B01 when the temperature exceeds the specified limit in compliance with the SCSI standard. The drive temperature is reported in the FRU code field of mode sense data. You can use this information to determine if the warning is due to the temperature exceeding the drive threatening temperature or the user-specified temperature.

This feature is controlled by the Enable Warning (EWasc) bit, and the reporting mechanism is controlled by the Method of Reporting Informational Exceptions field (MRIE) on the Informational Exceptions Control (IEC) mode page (1Ch).

The current algorithm implements two temperature trip points. The first trip point is set at 68°C which is the maximum temperature limit according to the drive specification. The second trip point is user-selectable using the Log Select command. The reference temperature parameter in the temperature log page (see Table 1) can

be used to set this trip point. The default value for this drive is 68°C, however, you can set it to any value in the range of 0 to 68°C. If you specify a temperature greater than 68°C in this field, the temperature is rounded down to 68°C. A sense code is sent to the host to indicate the rounding of the parameter field.

Table 1: Temperature Log Page (0Dh)

Parameter Code	Description
0000h	Primary Temperature
0001h	Reference Temperature

5.2.6 Drive Self Test (DST)

Drive Self Test (DST) is a technology designed to recognize drive fault conditions that qualify the drive as a failed unit. DST validates the functionality of the drive at a system level.

There are two test coverage options implemented in DST:

1. Extended test
2. Short test

The most thorough option is the extended test that performs various tests on the drive and scans every logical block address (LBA) of the drive. The short test is time-restricted and limited in length—it does not scan the entire media surface, but does some fundamental tests and scans portions of the media.

If DST encounters an error during either of these tests, it reports a fault condition. If the drive fails the test, remove it from service and return it to Seagate for service.

5.2.6.1 DST failure definition

The drive will present a “diagnostic failed” condition through the self-tests results value of the diagnostic log page if a functional failure is encountered during DST. The channel and servo parameters are not modified to test the drive more stringently, and the number of retries are not reduced. All retries and recovery processes are enabled during the test. If data is recoverable, no failure condition will be reported regardless of the number of retries required to recover the data.

The following conditions are considered DST failure conditions:

- Seek error after retries are exhausted
- Track-follow error after retries are exhausted
- Read error after retries are exhausted
- Write error after retries are exhausted

Recovered errors will not be reported as diagnostic failures.

5.2.6.2 Implementation

This section provides all of the information necessary to implement the DST function on this drive.

5.2.6.2.1 State of the drive prior to testing

The drive must be in a ready state before issuing the Send Diagnostic command. There are multiple reasons why a drive may not be ready, some of which are valid conditions, and not errors. For example, a drive may be in process of doing a format, or another DST. It is the responsibility of the host application to determine the “not ready” cause.

While not technically part of DST, a Not Ready condition also qualifies the drive to be returned to Seagate as a failed drive.

A Drive Not Ready condition is reported by the drive under the following conditions:

- Motor will not spin
- Motor will not lock to speed
- Servo will not lock on track
- Drive cannot read configuration tables from the disc

In these conditions, the drive responds to a Test Unit Ready command with an 02/04/00 or 02/04/03 code.

5.2.6.2.2 Invoking DST

To invoke DST, submit the Send Diagnostic command with the appropriate Function Code (001b for the short test or 010b for the extended test) in bytes 1, bits 5, 6, and 7.

5.2.6.2.3 Short and extended tests

DST has two testing options:

1. short
2. extended

These testing options are described in the following two subsections.

Each test consists of three segments: an electrical test segment, a servo test segment, and a read/verify scan segment.

Short test (Function Code: 001b)

The purpose of the short test is to provide a time-limited test that tests as much of the drive as possible within 120 seconds. The short test does not scan the entire media surface, but does some fundamental tests and scans portions of the media. A complete read/verify scan is not performed and only factual failures will report a fault condition. This option provides a quick confidence test of the drive.

Extended test (Function Code: 010b)

The objective of the extended test option is to empirically test critical drive components. For example, the seek tests and on-track operations test the positioning mechanism. The read operation tests the read head element and the media surface. The write element is tested through read/write/read operations. The integrity of the media is checked through a read/verify scan of the media. Motor functionality is tested by default as a part of these tests.

The anticipated length of the Extended test is reported through the Control Mode page.

5.2.6.2.4 Log page entries

When the drive begins DST, it creates a new entry in the Self-test Results Log page. The new entry is created by inserting a new self-test parameter block at the beginning of the self-test results log parameter section of the log page. Existing data will be moved to make room for the new parameter block. The drive reports 20 parameter blocks in the log page. If there are more than 20 parameter blocks, the least recent parameter block will be deleted. The new parameter block will be initialized as follows:

1. The Function Code field is set to the same value as sent in the DST command
2. The Self-Test Results Value field is set to Fh
3. The drive will store the log page to non-volatile memory

After a self-test is complete or has been aborted, the drive updates the Self-Test Results Value field in its Self-Test Results Log page in non-volatile memory. The host may use Log Sense to read the results from up to the last 20 self-tests performed by the drive. The self-test results value is a 4-bit field that reports the results of the test. If the field is set to zero, the drive passed with no errors detected by the DST. If the field is not set to zero, the test failed for the reason reported in the field.

The drive will report the failure condition and LBA (if applicable) in the Self-test Results Log parameter. The Sense key, ASC, ASCQ, and FRU are used to report the failure condition.

5.2.6.2.5 Abort

There are several ways to abort a diagnostic. You can use a SCSI Bus Reset or a Bus Device Reset message to abort the diagnostic.

You can abort a DST executing in background mode by using the abort code in the DST Function Code field. This will cause a 01 (self-test aborted by the application client) code to appear in the self-test results values log. All other abort mechanisms will be reported as a 02 (self-test routine was interrupted by a reset condition).

5.2.7 Product warranty

Beginning on the date of shipment to the customer and continuing for the period specified in your purchase contract, Seagate warrants that each product (including components and subassemblies) that fails to function properly under normal use due to defect in materials or workmanship or due to nonconformance to the applicable specifications will be repaired or replaced, at Seagate's option and at no charge to the customer, if returned by customer at customer's expense to Seagate's designated facility in accordance with Seagate's warranty procedure. Seagate will pay for transporting the repair or replacement item to the customer. For more detailed warranty information, refer to the standard terms and conditions of purchase for Seagate products on your purchase documentation.

The remaining warranty for a particular drive can be determined by calling Seagate Customer Service at 1-800-468-3472. You can also determine remaining warranty using the Seagate web site (www.seagate.com). The drive serial number is required to determine remaining warranty information.

Shipping

When transporting or shipping a drive, use only a Seagate-approved container. Keep your original box. Seagate approved containers are easily identified by the Seagate Approved Package label. Shipping a drive in a non-approved container voids the drive warranty.

Seagate repair centers may refuse receipt of components improperly packaged or obviously damaged in transit. Contact your authorized Seagate distributor to purchase additional boxes. Seagate recommends shipping by an air-ride carrier experienced in handling computer equipment.

Product repair and return information

Seagate customer service centers are the only facilities authorized to service Seagate drives. Seagate does not sanction any third-party repair facilities. Any unauthorized repair or tampering with the factory seal voids the warranty.

6.0 Physical/electrical specifications

This section provides information relating to the physical and electrical characteristics of the drive.

6.1 AC power requirements

None.

6.2 DC power requirements

The voltage and current requirements for a single drive are shown below. Values indicated apply at the drive connector. Notes are shown following table 4.

Table 2: DC power requirements for ST3450856FC model

		1 Gbit		2 Gbit		4 Gbit		
		Notes	(Amps)	(Amps)	(Amps)	(Amps)	(Amps)	(Amps)
Voltage			+5V	+12V [2]	+5V	+12V [2]	+5V	+12V [2]
Regulation	[5]		±5%	±5% [2]	±5%	±5% [2]	±5%	±5% [2]
Avg idle current $\overline{DC\bar{X}}$	[1] [7]		0.55	0.77	0.58	0.77	0.63	0.76
Maximum starting current								
(peak DC) DC	3 σ [3]		0.71	1.93	0.74	1.93	0.98	1.93
(peak AC) AC	3 σ [3]		0.89	4.68	0.92	4.55	1.14	4.64
Delayed motor start (max) DC	3 σ [1] [4]		0.49	0.03	0.51	0.04	0.59	0.04
Peak operating current:								
Typical $\overline{DC\bar{X}}$	[1] [6]		0.58	1.16	0.63	1.17	0.68	1.16
Maximum DC	3 σ [1]		0.59	1.20	0.64	1.20	0.68	1.20
Maximum (peak) DC	3 σ		1.06	2.80	1.12	2.78	1.18	2.76

Table 3: DC power requirements for ST3300656FC model

	Notes	1 Gbit		2 Gbit		4 Gbit	
		(Amps)	(Amps)	(Amps)	(Amps)	(Amps)	(Amps)
Voltage		+5V	+12V [2]	+5V	+12V [2]	+5V	+12V [2]
Regulation	[5]	±5%	±5% [2]	±5%	±5% [2]	±5%	±5% [2]
Avg idle current DC \bar{X}	[1] [7]	0.45	0.68	0.48	0.68	0.53	0.67
Maximum starting current							
(peak DC) DC	3 σ [3]	0.62	1.77	0.64	1.78	0.83	1.78
(peak AC) AC	3 σ [3]	0.74	4.27	0.84	4.15	1.15	4.23
Delayed motor start (max) DC	3 σ [1] [4]	0.43	0.04	0.45	0.04	0.50	0.04
Peak operating current:							
Typical DC \bar{X}	[1] [6]	0.48	1.09	0.58	1.09	0.58	1.08
Maximum DC	3 σ [1]	0.50	1.11	0.61	1.11	0.59	1.11
Maximum (peak) DC	3 σ	0.98	2.62	1.12	2.66	1.16	2.72

Table 4: DC power requirements for ST3146356FC model

	Notes	1 Gbit		2 Gbit		4 Gbit	
		(Amps)	(Amps)	(Amps)	(Amps)	(Amps)	(Amps)
Voltage		+5V	+12V [2]	+5V	+12V [2]	+5V	+12V [2]
Regulation	[5]	±5%	±5% [2]	±5%	±5% [2]	±5%	±5% [2]
Avg idle current DC \bar{X}	[1] [7]	0.55	0.53	0.58	0.53	0.64	0.53
Maximum starting current							
(peak DC) DC	3 σ [3]	0.69	1.82	0.72	1.81	0.98	1.81
(peak AC) AC	3 σ [3]	0.84	3.85	0.88	3.79	1.17	3.90
Delayed motor start (max) DC	3 σ [1] [4]	0.49	0.03	0.52	0.03	0.59	0.04
Peak operating current:							
Typical DC \bar{X}	[1] [6]	0.63	0.92	0.66	0.91	0.69	0.91
Maximum DC	3 σ [1]	0.63	0.95	0.66	0.95	0.71	0.94
Maximum (peak) DC	3 σ	1.10	2.40	1.16	2.46	1.20	2.48

- [1] Measured with average reading DC ammeter. Instantaneous +12V current peaks will exceed these values. Power supply at nominal voltage. N (number of drives tested) = 6, 35 Degrees C ambient.
- [2] For +12 V, a -10% tolerance is allowed during initial spindle start but must return to ±5% before reaching 15000 RPM. The ±5% must be maintained after the drive signifies that its power-up sequence has been completed and that the drive is able to accept selection by the host initiator.
- [3] See +12V current profile in Figure 1.
- [4] This condition occurs when the Motor Start option is enabled and the drive has not yet received a Start Motor command.
- [5] See paragraph 6.2.1, "Conducted noise immunity." Specified voltage tolerance includes ripple, noise, and transient response.
- [6] Operating condition is defined as random 8 block reads at 330 I/Os per second for ST3450856FC and

347 I/Os per second for ST3300656FC and ST3146356FC models. Current and power specified at nominal voltages.

- [7] During idle, the drive heads are relocated every 60 seconds to a random location within the band from three-quarters to maximum track.

General DC power requirement notes.

1. Minimum current loading for each supply voltage is not less than 1.2% of the maximum operating current shown.
2. The +5V and +12V supplies should employ separate ground returns.
3. Where power is provided to multiple drives from a common supply, careful consideration for individual drive power requirements should be noted. Where multiple units are powered on simultaneously, the peak starting current must be available to each device.
4. Parameters, other than spindle start, are measured after a 10-minute warm up.
5. No terminator power.

6.2.1 Conducted noise immunity

Noise is specified as a periodic and random distribution of frequencies covering a band from DC to 10 MHz. Maximum allowed noise values given below are peak-to-peak measurements and apply at the drive power connector.

- +5 V = 250 mV pp from 0 to 100 kHz to 20 MHz.
- +12 V = 800 mV pp from 100 Hz to 8 KHz.
450 mV pp from 8 KHz to 20 KHz.
250 mV pp from 20 KHz to 5 MHz.

6.2.2 Power sequencing

The drive does not require power sequencing. The drive protects against inadvertent writing during power-up and down.

6.2.3 Current profiles

The +12V and +5V current profiles are shown in the following figures.

Note: All times and currents are typical. See Tables 2, 3, and 4 for maximum current requirements.

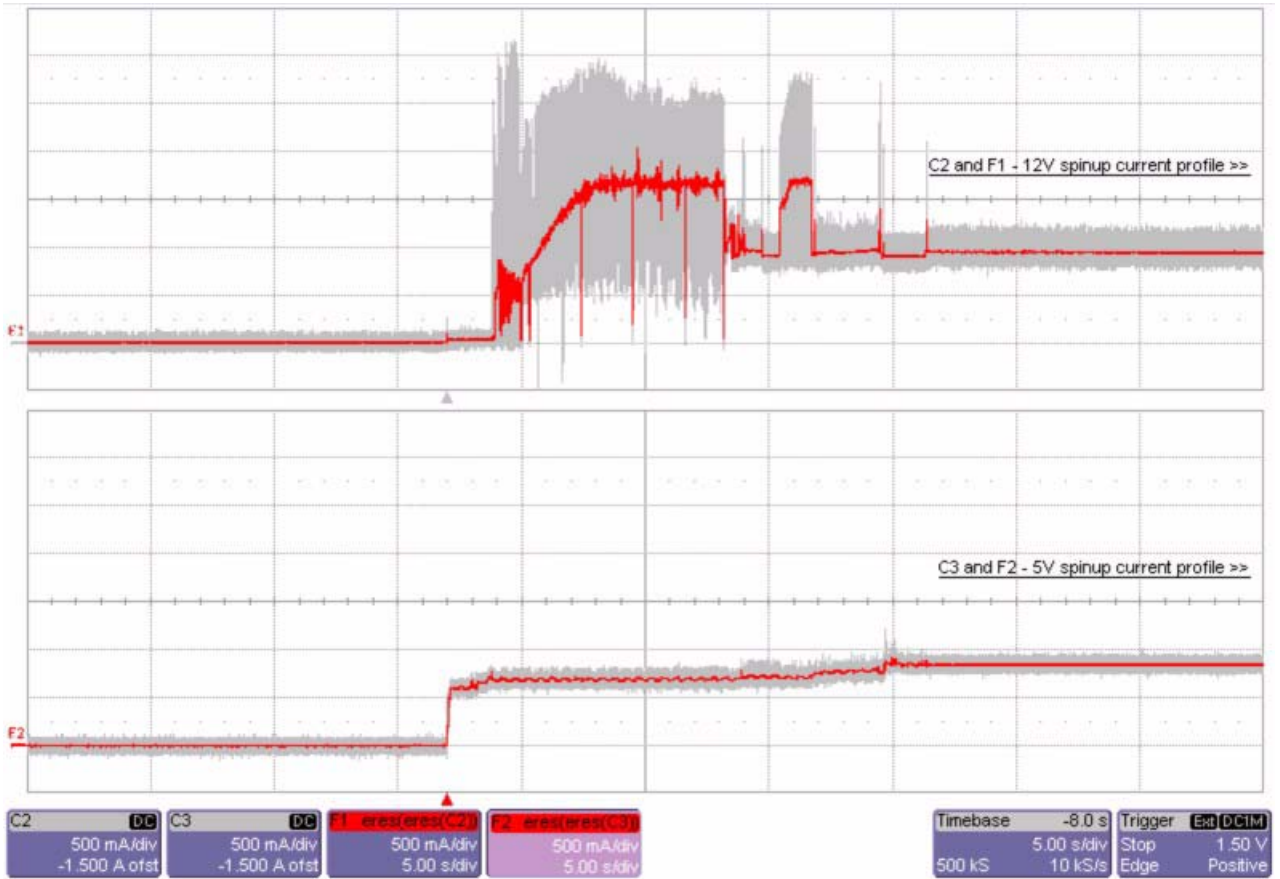

Figure 1. Typical ST3450856FC current profiles

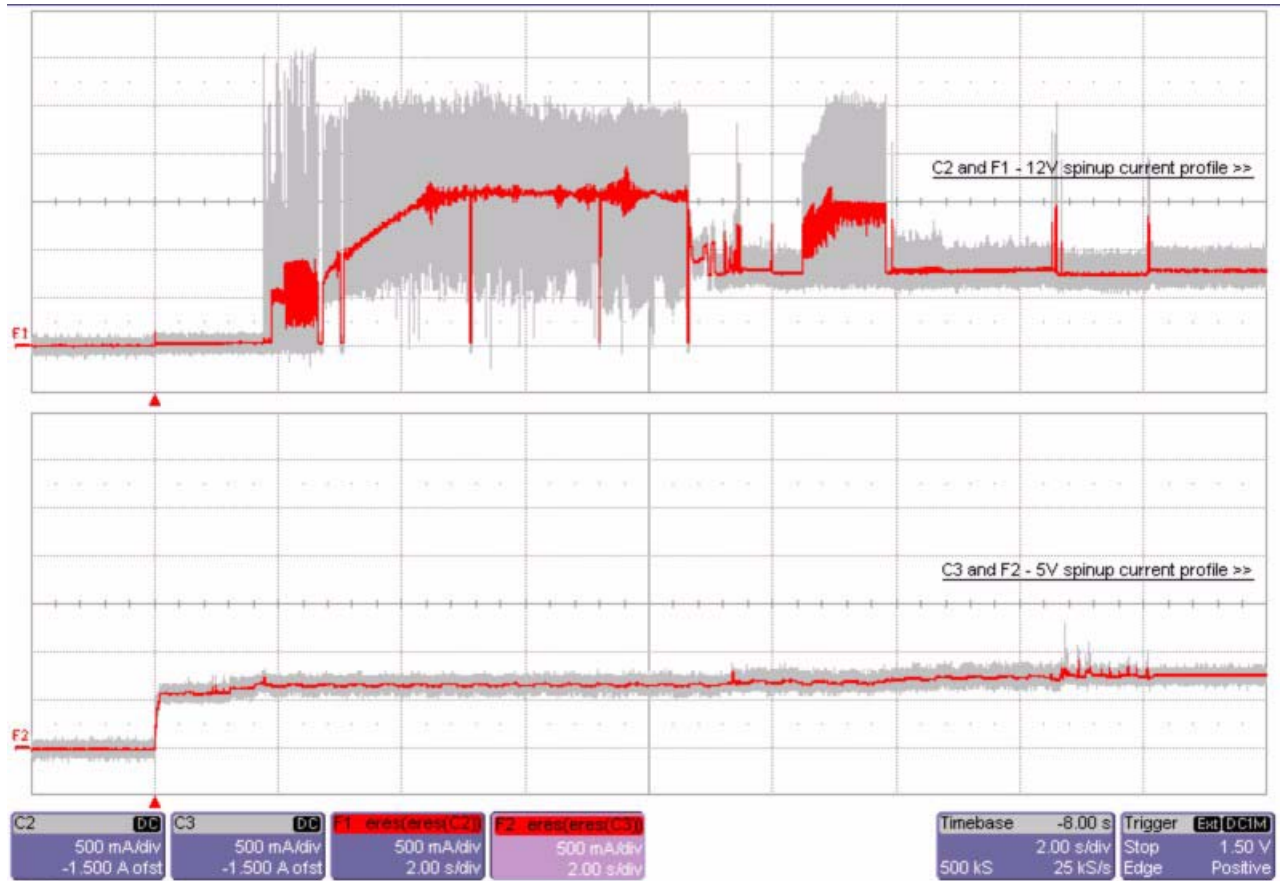

Figure 2. Typical ST3300656FC current profiles

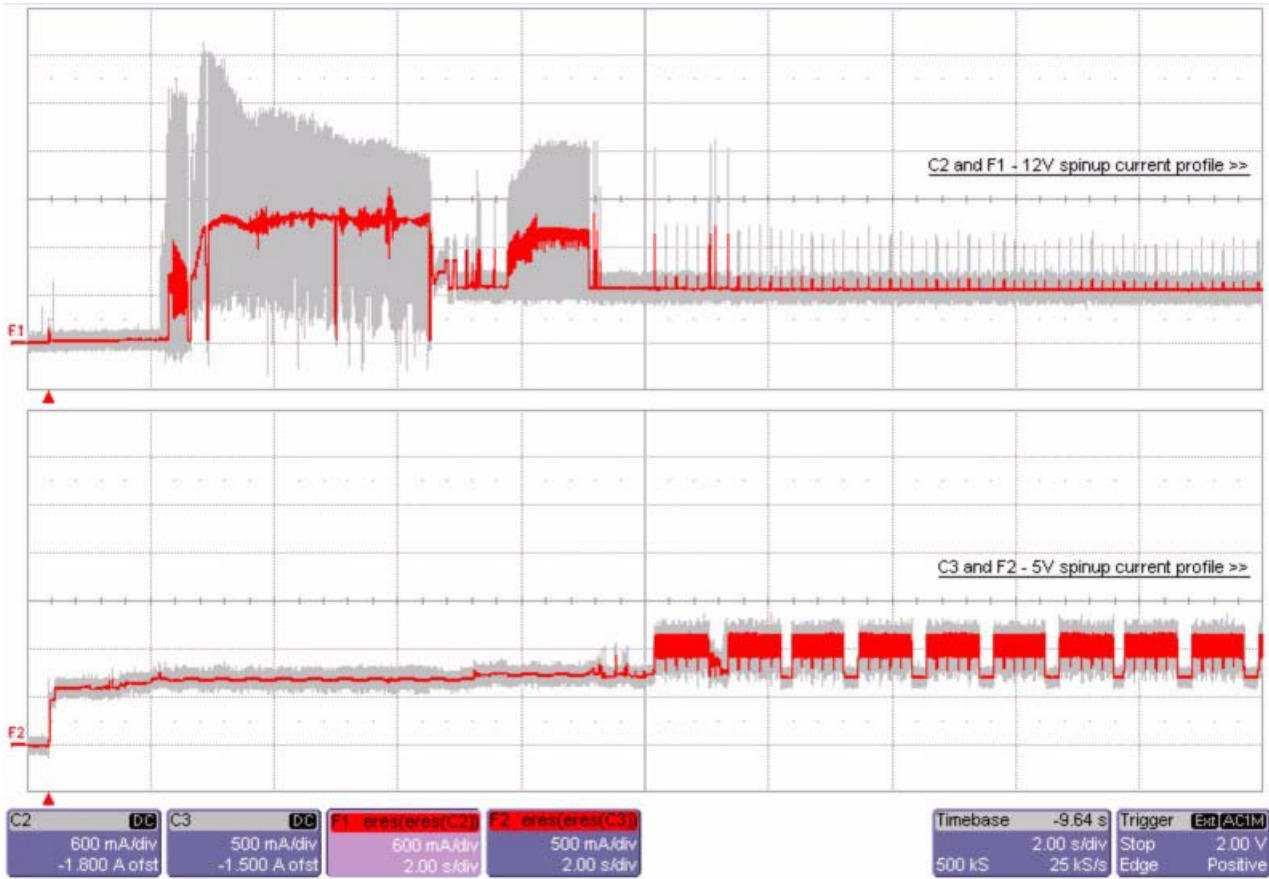

Figure 3. Typical ST3146356FC current profiles

6.3 Power dissipation

ST3450856FC

Typical power dissipation under idle conditions in 4 Gbit operation is 12.27 watts (41.9 BTUs per hour).

To obtain operating power for typical random read operations, refer to the following I/O rate curve (see Figure 4). Locate the typical I/O rate for a drive in your system on the horizontal axis and read the corresponding +5 volt current, +12 volt current, and total watts on the vertical axis. To calculate BTUs per hour, multiply watts by 3.4123.

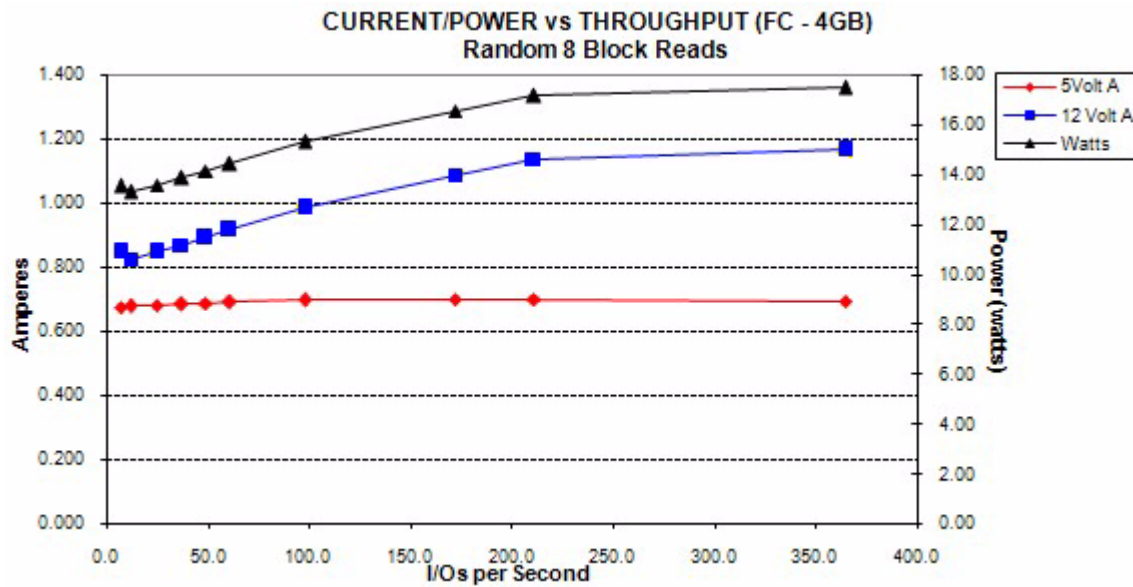

Figure 4. ST3450856FC DC current and power vs. input/output operations per second at 4 Gbit

ST3300656FC

Typical power dissipation under idle conditions in 4 Gbit operation is 10.69 watts (36.5 BTUs per hour).

To obtain operating power for typical random read operations, refer to the following I/O rate curve (see Figure 4). Locate the typical I/O rate for a drive in your system on the horizontal axis and read the corresponding +5 volt current, +12 volt current, and total watts on the vertical axis. To calculate BTUs per hour, multiply watts by 3.4123.

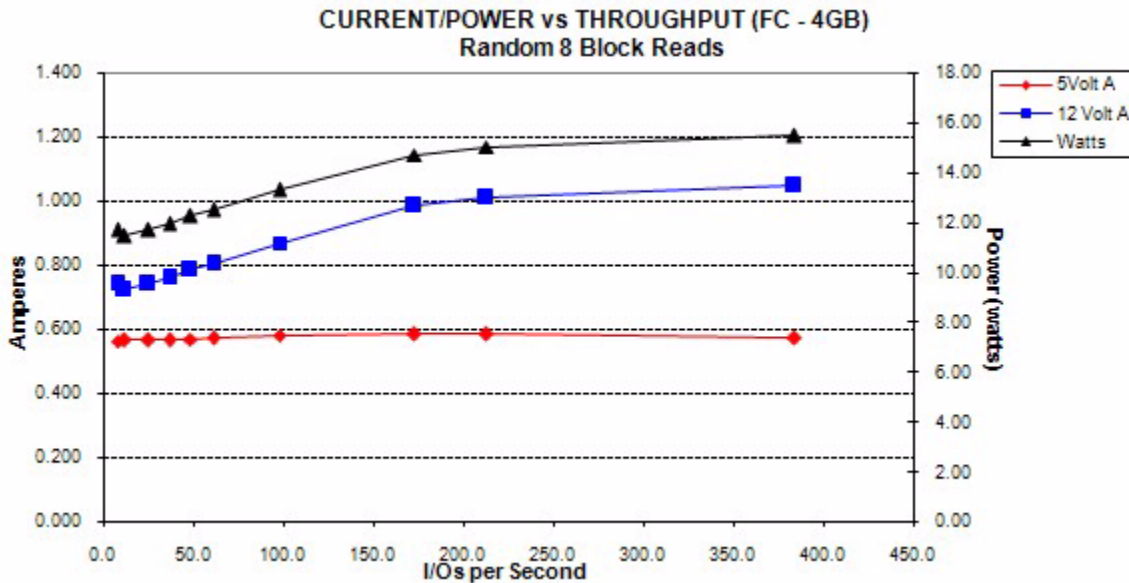

Figure 5. ST3300656FC DC current and power vs. input/output operations per second at 4 Gbit

ST3146356FC

Typical power dissipation under idle conditions in 4 Gbit operation is 9.56 watts (32.6 BTUs per hour).

To obtain operating power for typical random read operations, refer to the following I/O rate curve (see Figure 4). Locate the typical I/O rate for a drive in your system on the horizontal axis and read the corresponding +5 volt current, +12 volt current, and total watts on the vertical axis. To calculate BTUs per hour, multiply watts by 3.4123.

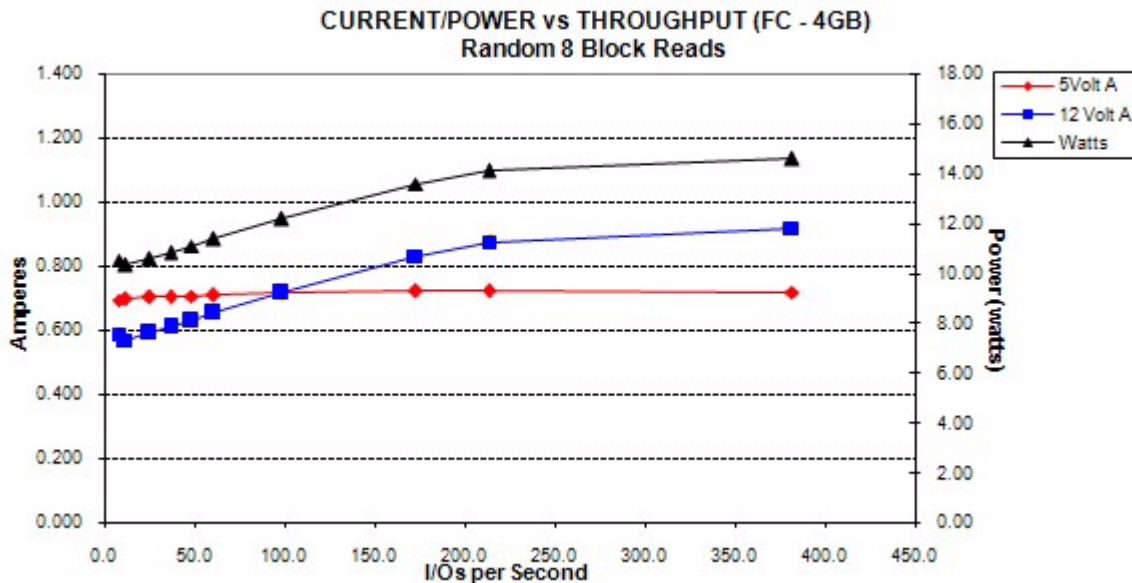

Figure 6. ST3146356FC DC current and power vs. input/output operations per second at 4 Gbit

6.4 Environmental limits

Temperature and humidity values experienced by the drive must be such that condensation does not occur on any drive part. Altitude and atmospheric pressure specifications are referenced to a standard day at 58.7°F (14.8°C). Maximum wet bulb temperature is 82°F (28°C).

6.4.1 Temperature

a. Operating

The maximum allowable continuous or sustained HDA case temperature for the rated Annualized Failure Rate (AFR) is 122°F (50°C). The maximum allowable HDA case temperature is 60°C. Occasional excursions of HDA case temperatures above 122°F (50°C) or below 41°F (5°C) may occur without impact to the specified AFR. Continual or sustained operation at HDA case temperatures outside these limits may degrade AFR.

Provided the HDA case temperatures limits are met, the drive meets all specifications over a 41°F to 131°F (5°C to 55°C) drive ambient temperature range with a maximum temperature gradient of 36°F (20°C) per hour. Air flow may be needed in the drive enclosure to keep within this range (see Section 8.3). Operation at HDA case temperatures outside this range may adversely affect the drives ability to meet specifications. To confirm that the required cooling for the electronics and HDA case is provided, place the drive in its final mechanical configuration, perform random write/read operations and measure the HDA case temperature after it has stabilized.

b. Non-operating

–40° to 158°F (–40° to 70°C) package ambient with a maximum gradient of 36°F (20°C) per hour. This specification assumes that the drive is packaged in the shipping container designed by Seagate for use with drive.

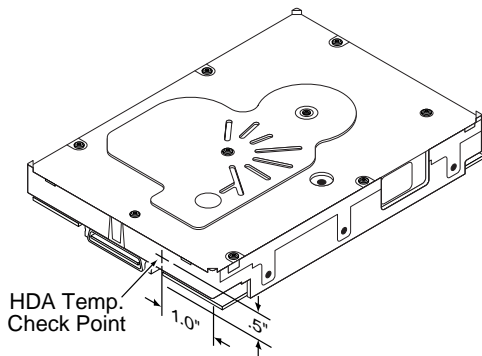

Figure 7. Locations of the HDA temperature check point

6.4.2 Relative humidity

The values below assume that no condensation on the drive occurs.

a. Operating

5% to 95% non-condensing relative humidity with a maximum gradient of 20% per hour.

b. Non-operating

5% to 95% non-condensing relative humidity.

6.4.3 Effective altitude (sea level)

a. Operating

–1,000 to +10,000 feet (–305 to +3,048 meters)

b. Non-operating

–1,000 to +40,000 feet (–305 to +12,210 meters)

6.4.4 Shock and vibration

Shock and vibration limits specified in this document are measured directly on the drive chassis. If the drive is installed in an enclosure to which the stated shock and/or vibration criteria is applied, resonances may occur internally to the enclosure resulting in drive movement in excess of the stated limits. If this situation is apparent, it may be necessary to modify the enclosure to minimize drive movement.

The limits of shock and vibration defined within this document are specified with the drive mounted by any of the four methods shown in Figure 8, and in accordance with the restrictions of Section 8.4. Orientation of the side nearest the LED may be up or down.

6.4.4.1 Shock

a. Operating—normal

The drive, as installed for normal operation, shall operate error free while subjected to intermittent shock not exceeding 15 Gs at a maximum duration of 11 msec (half sinewave). The drive, as installed for normal operation, shall operate error free while subjected to intermittent shock not exceeding 25 Gs at a maximum duration of 2 msec (half sinewave). Shock may be applied in the X, Y, or Z axis.

b. Operating—abnormal

Equipment, as installed for normal operation, does not incur physical damage while subjected to intermittent shock not exceeding 40 Gs at a maximum duration of 11 msec (half sinewave). Shock occurring at abnormal levels may promote degraded operational performance during the abnormal shock period. Specified operational performance will continue when normal operating shock levels resume. Shock may be applied in the X, Y, or Z axis. Shock is not to be repeated more than two times per second.

c. Non-operating

The limits of non-operating shock shall apply to all conditions of handling and transportation. This includes both isolated drives and integrated drives.

The drive subjected to nonrepetitive shock not exceeding 80 Gs at a maximum duration of 11 msec (half sinewave) shall not exhibit device damage or performance degradation. Shock may be applied in the X, Y, or Z axis.

The drive subjected to nonrepetitive shock not exceeding 300 Gs at a maximum duration of 2 msec (half sinewave) does not exhibit device damage or performance degradation. Shock may be applied in the X, Y, or Z axis.

The drive subjected to nonrepetitive shock not exceeding 150 Gs at a maximum duration of 0.5 msec (half sinewave) does not exhibit device damage or performance degradation. Shock may be applied in the X, Y, or Z axis.

d. Packaged

Disc drives shipped as loose load (not palletized) general freight will be packaged to withstand drops from heights as defined in the table below. For additional details refer to Seagate specifications 30190-001 (under 100 lbs/45 kg) or 30191-001 (over 100 lbs/45 Kg).

Package size	Packaged/product weight	Drop height
<600 cu in (<9,800 cu cm)	Any	60 in (1524 mm)
600-1800 cu in (9,800-19,700 cu cm)	0-20 lb (0 to 9.1 kg)	48 in (1219 mm)
>1800 cu in (>19,700 cu cm)	0-20 lb (0 to 9.1 kg)	42 in (1067 mm)
>600 cu in (>9,800 cu cm)	20-40 lb (9.1 to 18.1 kg)	36 in (914 mm)

Drives packaged in single or multipacks with a gross weight of 20 pounds (8.95 kg) or less by Seagate for general freight shipment shall withstand a drop test from 48 inches (1,070 mm) against a concrete floor or equivalent.

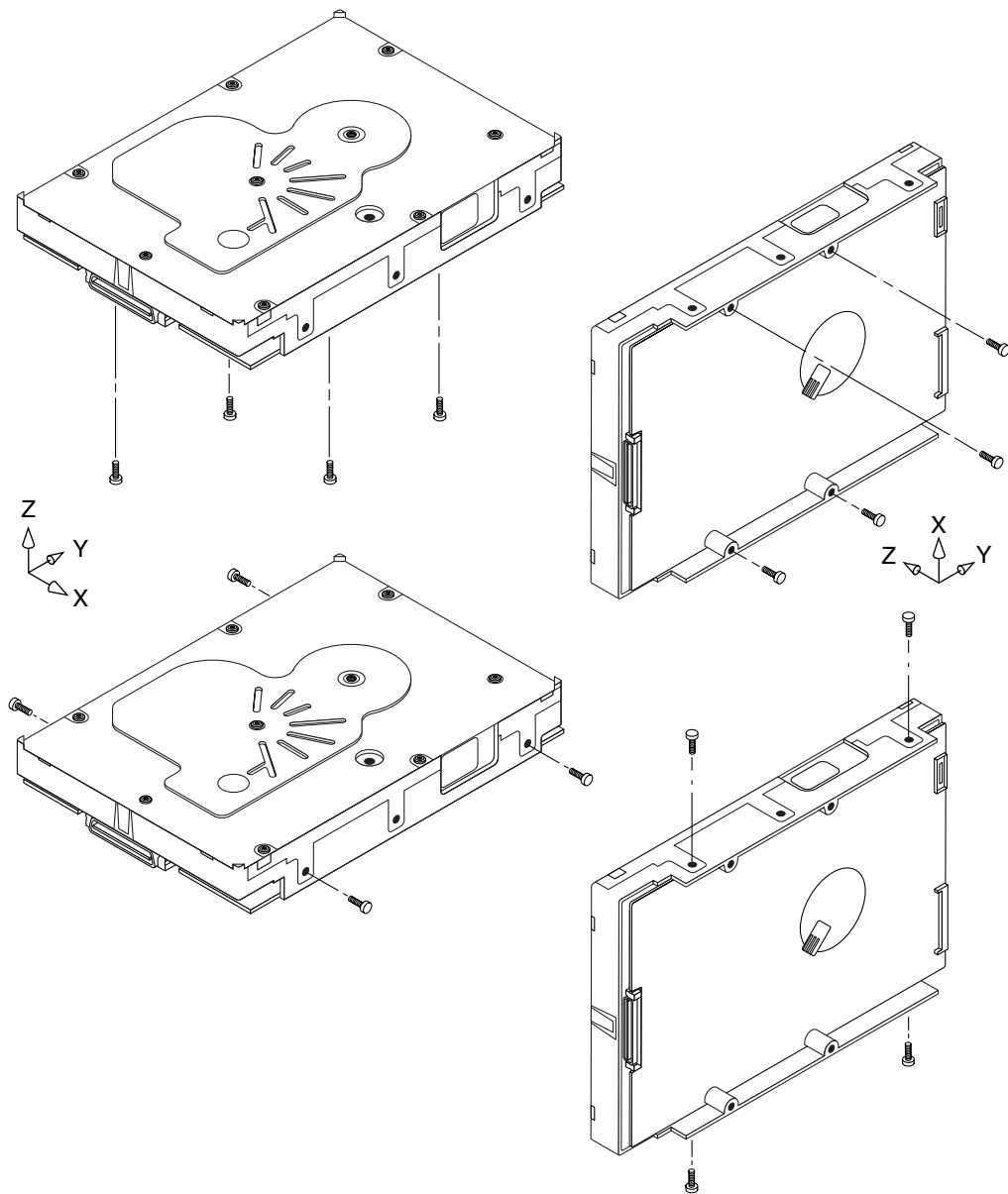

Figure 8. Recommended mounting

6.4.4.2 Vibration

a. Operating—normal

The drive as installed for normal operation, shall comply with the complete specified performance while subjected to continuous vibration not exceeding

10–500 Hz @ 0.5 G (zero to peak)

Vibration may be applied in the X, Y, or Z axis.

Operating normal translational random flat profile

10–500 Hz 0.4 g RMS

b. Operating—abnormal

Equipment as installed for normal operation shall not incur physical damage while subjected to periodic vibration not exceeding:

15 minutes of duration at major resonant frequency

10–500 Hz @ 0.75 G (X, Y, or Z axis)

Vibration occurring at these levels may degrade operational performance during the abnormal vibration period. Specified operational performance will continue when normal operating vibration levels are resumed. This assumes system recovery routines are available.

Operating abnormal translational random flat profile

10–500 Hz 1.2 g RMS

c. Non-operating

The limits of non-operating vibration shall apply to all conditions of handling and transportation. This includes both isolated drives and integrated drives.

The drive shall not incur physical damage or degraded performance as a result of continuous vibration not exceeding

5–500 Hz at 3G

Amplitudes above 1.0 G in the frequency range of 5-20 Hz may be limited due to shaker equipment stroke limitations.

Vibration may be applied in the X, Y, or Z axis.

Non-operating translational random flat profile

10–500 Hz 1.2 g RMS

6.4.5 Acoustics

Sound power during idle mode shall be 3.5 bels typical when measured to ISO 7779 specification. Sound power while operating shall be 3.7 bels typical when measured to ISO 7779 specification.

There will not be any discrete tones more than 10 dB above the masking noise on typical drives when measured according to Seagate specification 30553-001. There will not be any tones more than 24 dB above the masking noise on any drive.

6.4.6 Air cleanliness

The drive is designed to operate in a typical office environment with minimal environmental control.

6.4.7 Corrosive environment

Seagate electronic drive components pass accelerated corrosion testing equivalent to 10 years exposure to light industrial environments containing sulfurous gases, chlorine and nitric oxide, classes G and H per ASTM B845. However, this accelerated testing cannot duplicate every potential application environment.

Users should use caution exposing any electronic components to uncontrolled chemical pollutants and corrosive chemicals as electronic drive component reliability can be affected by the installation environment. The silver, copper, nickel and gold films used in Seagate products are especially sensitive to the presence of sulfide, chloride, and nitrate contaminants. Sulfur is found to be the most damaging. In addition, electronic components should never be exposed to condensing water on the surface of the printed circuit board assembly (PCBA) or exposed to an ambient relative humidity greater than 95%. Materials used in cabinet fabrication, such as vulcanized rubber, that can outgas corrosive compounds should be minimized or eliminated. The useful life of any electronic equipment may be extended by replacing materials near circuitry with sulfide-free alternatives.

6.4.8 RoHS compliance statement

The European Union Restriction of Hazardous Substances (RoHS) Directive restricts the presence of chemical substances, including Lead (Pb), in electronic products effective July 2006. Although amendments to the European Union's Restriction of Hazardous Substances (RoHS) Directive have not been finalized, to the best of our knowledge the disc drives documented in this publication will comply with the final RoHS Directive requirements.

A number of parts and materials in Seagate products are procured from external suppliers. We rely on the representations of our suppliers regarding the presence of RoHS substances in these parts and materials. Our supplier contracts require compliance with our chemical substance restrictions, and our suppliers document their compliance with our requirements by providing material content declarations for all parts and materials for the disc drives documented in this publication. Current supplier declarations include disclosure of the inclusion of any RoHS-regulated substance in such parts or materials.

Seagate also has internal systems in place to ensure ongoing compliance with the RoHS Directive and all laws and regulations which restrict chemical content in electronic products. These systems include standard operating procedures that ensure that restricted substances are not utilized in our manufacturing operations, laboratory analytical validation testing, and an internal auditing process to ensure that all standard operating procedures are complied with.

6.4.9 Electromagnetic susceptibility

See Section 2.1.1.1.

6.5 Mechanical specifications

The following nominal dimensions are exclusive of the decorative front panel accessory. However, dimensions of the front panel are shown in figure below. Refer to Figure 9 for detailed mounting configuration dimensions. See Section 8.4, "Drive mounting."

Height (max):	1.028 in	26.11 mm
Width (max):	4.010 in	101.85 mm
Depth (max):	5.787 in	146.99 mm
Weight:	ST3450856FC: 1.563 pounds	0.709 kilograms
	ST3300656FC: 1.53 pounds	0.694 kilograms
	ST3146356FC: 1.487 pounds	0.674 kilograms

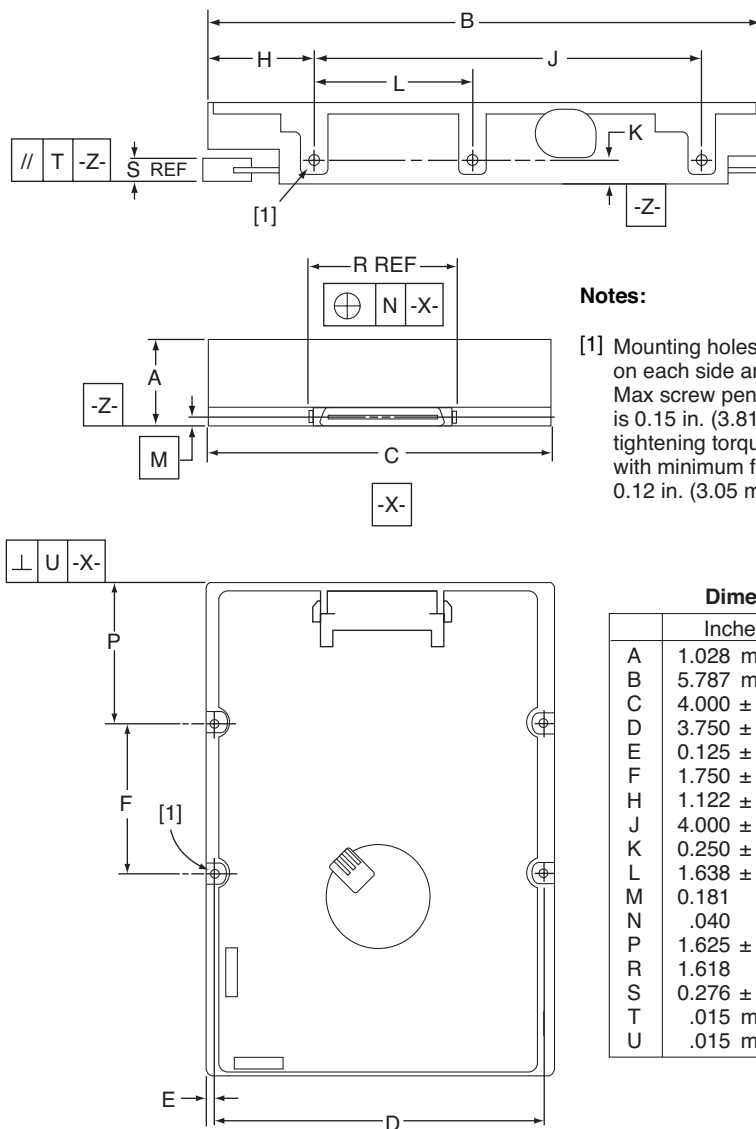

Notes:

[1] Mounting holes are 6-32 UNC 2B, three on each side and four on the bottom. Max screw penetration into side of drive is 0.15 in. (3.81 mm). Max screw tightening torque is 6.0 in-lb (3.32 nm) with minimum full thread engagement of 0.12 in. (3.05 mm).

Dimension Table

	Inches	Millimeters
A	1.028 max	26.10 max
B	5.787 max	147.00 max
C	4.000 ± .010	101.60 ± .25
D	3.750 ± .010	95.25 ± .25
E	0.125 ± .010	3.18 ± .25
F	1.750 ± .010	44.45 ± .25
H	1.122 ± .020	28.50 ± .50
J	4.000 ± .010	101.60 ± .25
K	0.250 ± .010	6.35 ± .25
L	1.638 ± .010	41.60 ± .25
M	0.181	4.60
N	.040	1.02
P	1.625 ± .020	41.28 ± .50
R	1.618	41.10
S	0.276 ± .040	7.00 ± 1.02
T	.015 max	0.38 max
U	.015 max	0.38 max

Figure 9. Mounting configuration dimensions

7.0 Defect and error management

Seagate continues to use innovative technologies to manage defects and errors. These technologies are designed to increase data integrity, perform drive self-maintenance, and validate proper drive operation.

SCSI defect and error management involves drive internal defect/error management and FC system error considerations (errors in communications between the initiator and the drive). In addition, Seagate provides the following technologies used to increase data integrity and drive reliability:

- Background Media Scan (see Section 7.4)
- Media Pre-Scan (see Section 7.5)
- Deferred Auto-Reallocation (see Section 7.6)
- Idle Read After Write (see Section 7.7)

The read error rates and specified storage capacities are not dependent on host (initiator) defect management routines.

7.1 Drive internal defects/errors

During the initial drive format operation at the factory, media defects are identified, tagged as being unusable, and their locations recorded on the drive primary defects list (referred to as the “P” list and also as the ETF defect list). At factory format time, these known defects are also reallocated, that is, reassigned to a new place on the medium and the location listed in the defects reallocation table. The “P” list is not altered after factory formatting. Locations of defects found and reallocated during error recovery procedures after drive shipment are listed in the “G” list (defects growth list). The “P” and “G” lists may be referenced by the initiator using the Read Defect Data command.

Details of the SCSI commands supported by the drive are described in the *Fibre Channel Interface Manual*. Also, more information on the drive Error Recovery philosophy is presented in the *Fibre Channel Interface Manual*.

7.2 Drive error recovery procedures

When an error occurs during drive operation, the drive, if programmed to do so, performs error recovery procedures to attempt to recover the data. The error recovery procedures used depend on the options previously set in the Error Recovery Parameters mode page. Error recovery and defect management may involve using several SCSI commands described in the *Fibre Channel Interface Manual*. The drive implements selectable error recovery time limits required in video applications.

The error recovery scheme supported by the drive provides a way to control the total error recovery time for the entire command in addition to controlling the recovery level for a single LBA. The total amount of time spent in error recovery for a command can be limited using the Recovery Time Limit bytes in the Error Recovery mode page. The total amount of time spent in error recovery for a single LBA can be limited using the Read Retry Count or Write Retry Count bytes in the Error Recovery mode page.

The drive firmware error recovery algorithms consists of 13 levels for read recoveries and five levels for write. Each level may consist of multiple steps, where a step is defined as a recovery function involving a single re-read or re-write attempt. The maximum level used by the drive in LBA recovery is determined by the read and write retry counts.

Table 5 equates the read and write retry count with the maximum possible recovery time for read and write recovery of individual LBAs. The times given do not include time taken to perform reallocations. Reallocations are performed when the ARRE bit (for reads) or AWRE bit (for writes) is one, the RC bit is zero, and the recovery time limit for the command has not yet been met. Time needed to perform reallocation is not counted against the recovery time limit.

When the RC bit is one, reallocations are disabled even if the ARRE or AWRE bits are one. The drive will still perform data recovery actions within the limits defined by the Read Retry Count, Write Retry Count, and Recovery Time Limit parameters. However, the drive does not report any unrecovered errors.

Table 5: Read and write retry count maximum recovery times [1]

Read retry count	Maximum recovery time per LBA (cumulative, msec)	Write retry count	Maximum recovery time per LBA (cumulative, msec)
0	51.87	0	23.94
1	59.85	1	35.91
2	203.49	2	55.86
3	219.45	3	67.83
4	231.42	4	119.79
5	297.38	5 (default)	147.72
6	323.62		
7	355.54		
8	439.39		
9	507.39		
10	539.31		
11	567.24		
12	1,460.86		
13 (default)	1,468.74		

[1] These values are subject to change.

Setting these retry counts to a value below the default setting could result in an increased unrecovered error rate which may exceed the value given in this product manual. A setting of zero (0) will result in the drive not performing error recovery.

For example, suppose the Read/Write Recovery page has the RC bit set to 0, read retry count set to 4, and the recovery time limit field (Mode Sense page 01, bytes 10 and 11) set to FF FF hex (maximum). A four LBA Read command is allowed to take up to 253.11 msec recovery time for each of the four LBAs in the command. If the recovery time limit is set to 00 C8 hex (200 msec decimal) a four LBA read command is allowed to take up to 200 msec for all error recovery within that command. The use of the Recovery Time Limit field allows finer granularity on control of the time spent in error recovery. The recovery time limit only starts counting when the drive is executing error recovery and it restarts on each command. Therefore, each command's total recovery time is subject to the recovery time limit. Note: A recovery time limit of 0 will use the drive's default value of FF FF. Minimum recovery time limit is achieved by setting the Recovery Time Limit field to 00 01.

7.3 FC-AL system errors

Information on the reporting of operational errors or faults across the interface is given in the *Fibre Channel Interface Manual*. The FCP Response returns information to the host about numerous kinds of errors or faults. The Receive Diagnostic Results reports the results of diagnostic operations performed by the drive.

Status returned by the drive to the initiator is described in the *Fibre Channel Interface Manual*. Status reporting plays a role in systems error management and its use in that respect is described in sections where the various commands are discussed.

7.4 Background Media Scan

Background Media Scan (BMS) is a self-initiated media scan. BMS is defined in the T10 document SPC-4 available from the T10 committee. BMS performs sequential reads across the entire pack of the media while the drive is idle. In RAID arrays, BMS allows hot spare drives to be scanned for defects prior to being put into

service by the host system. On regular duty drives, if the host system makes use of the BMS Log Page, it can avoid placing data in suspect locations on the media. Unreadable and recovered error sites will be logged or reallocated per ARRE/AWRE settings.

With BMS, the host system can consume less power and system overhead by only checking BMS status and results rather than tying up the bus and consuming power in the process of host-initiated media scanning activity.

Since the background scan functions are only done during idle periods, BMS causes a negligible impact to system performance. The first BMS scan for a newly manufactured drive is performed as quickly as possible to verify the media and protect data by setting the “Start time after idle” to 5ms, all subsequent scans begin after 500ms of idle time. Other features that normally use idle time to function will function normally because BMS functions for bursts of 800ms and then suspends activity for 100ms to allow other background functions to operate.

BMS interrupts immediately to service host commands from the interface bus while performing reads. BMS will complete any BMS-initiated error recovery prior to returning to service host-initiated commands. Overhead associated with a return to host-servicing activity from BMS only impacts the first command that interrupted BMS, this results in a typical delay of about 1 ms.

7.5 Media Pre-Scan

Media Pre-Scan is a feature that allows the drive to repair media errors that would otherwise have been found by the host system during critical data accesses early in the drive’s life. The default setting for Media Pre-Scan is enabled on standard products. Media Pre-Scan checks each write command to determine if the destination LBAs have been scanned by BMS. If the LBAs have been verified, the drive proceeds with the normal write command. If the LBAs have not been verified by BMS, Pre-Scan will convert the write to a write verify to certify that the data was properly written to the disc.

Note. During Pre-Scan write verify commands, write performance may decrease by 50% until Pre-Scan completes. Write performance testing should be performed after Pre-Scan is complete. This may be checked by reading the BMS status.

To expedite the scan of the full pack and subsequently exit from the Pre-Scan period, BMS will begin scanning immediately when the drive goes to idle during the Pre-Scan period. In the event that the drive is in a high transaction traffic environment and is unable to complete a BMS scan within 24 power on hours BMS will disable Pre-Scan to restore full performance to the system.

7.6 Deferred Auto-Reallocation

Deferred Auto-Reallocation (DAR) simplifies reallocation algorithms at the system level by allowing the drive to reallocate unreadable locations on a subsequent write command. Sites are marked for DAR during read operations performed by the drive. When a write command is received for an LBA marked for DAR, the auto-reallocation process is invoked and attempts to rewrite the data to the original location. If a verification of this rewrite fails, the sector is re-mapped to a spare location.

This is in contrast to the system having to use the Reassign Command to reassign a location that was unreadable and then generate a write command to rewrite the data. DAR is most effective when AWRE and ARRE are enabled—this is the default setting from the Seagate factory. With AWRE and ARRE disabled DAR is unable to reallocate the failing location and will report an error sense code indicating that a write command is being attempted to a previously failing location.

7.7 Idle Read After Write

Idle Read After Write (IRAW) utilizes idle time to verify the integrity of recently written data. During idle periods, no active system requests, the drive reads recently written data from the media and compares it to valid write command data resident in the drives data buffer. Any sectors that fail the comparison result in the invocation of a rewrite and auto-reallocation process. The process attempts to rewrite the data to the original location. If a verification of this rewrite fails, the sector is re-mapped to a spare location.

8.0 Installation

Cheetah 15K.6 FC disc drive installation is a plug-and-play process. There are no jumpers, switches, or terminators on the drive. Simply plug the drive into the host's 40-pin Fibre Channel backpanel connector (FC-SCA)—no cables are required. See Section 9.5 for additional information about this connector.

Use the FC-AL interface to select drive ID and all option configurations for devices on the loop.

If multiple devices are on the same FC-AL and physical addresses are used, set the device selection IDs (SEL IDs) on the backpanel so that no two devices have the same selection ID. This is called the hard assigned arbitrated loop physical address (AL_PA). There are 125 AL_PAs available (see Table 27). If you set the AL_PA on the backpanel to any value other than 0, the device plugged into the backpanel's SCA connector inherits this AL_PA. In the event you don't successfully assign unique hard addresses (and therefore have duplicate selection IDs assigned to two or more devices), the FC-AL generates a message indicating this condition. If you set the AL_PA on the backpanel to a value of 0, the system issues a unique soft-assigned physical address automatically.

Loop initialization is the process used to verify or obtain an address. The loop initialization process is performed when power is applied to the drive, when a device is added or removed from the Fibre Channel loop, or when a device times out attempting to win arbitration.

- Set all option selections in the connector prior to applying power to the drive. If you change options after applying power to the drive, recycle the drive power to activate the new settings.
- It is not necessary to low-level format this drive. The drive is shipped from the factory low-level formatted in 512-byte logical blocks. You need to reformat the drive only if you want to select a different logical block size.

8.1 Drive ID/option selection

All drive options are made through the interface connector (J1). Table 24 provides the pin descriptions for the 40-pin Fibre Channel single connector (J1).

8.2 Drive orientation

The drive may be mounted in any orientation. All drive performance characterizations, however, have been done with the drive in horizontal (discs level) and vertical (drive on its side) orientations, which are the two preferred mounting orientations.

8.3 Cooling

The host enclosure must dissipate heat from the drive. You should confirm that the host enclosure is designed to ensure that the drive operates within the temperature measurement guidelines described in Section 6.4.1. In some cases, forced airflow may be required to keep temperatures at or below the temperatures specified in Section 6.4.1.

If forced air is necessary, possible air-flow patterns are shown in Figure 10. The air-flow patterns are created by fans either forcing or drawing air as shown in the illustrations. Conduction, convection, or other forced air-flow patterns are acceptable as long as the temperature measurement guidelines of Section 6.4.1 are met.

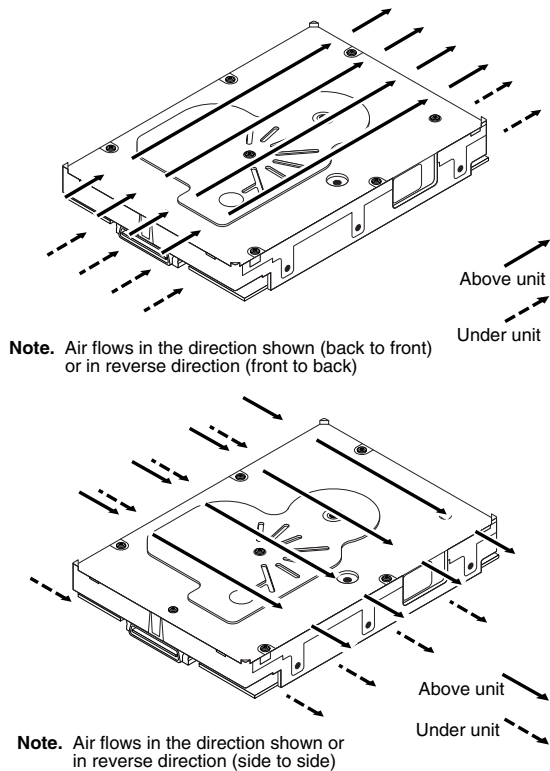

Figure 10. Air flow

8.4 Drive mounting

Mount the drive using the bottom or side mounting holes. If you mount the drive using the bottom holes, ensure that you do not physically distort the drive by attempting to mount it on a stiff, non-flat surface.

The allowable mounting surface stiffness is 80 lb/in (14.0 N/mm). The following equation and paragraph define the allowable mounting surface stiffness:

$$K \times X = F \leq 15\text{lb} = 67\text{N}$$

where K is the mounting surface stiffness (units in lb/in or N/mm) and X is the out-of-plane surface distortion (units in inches or millimeters). The out-of-plane distortion (X) is determined by defining a plane with three of the four mounting points fixed and evaluating the out-of-plane deflection of the fourth mounting point when a known force (F) is applied to the fourth point.

Note. Before mounting the drive in any kind of 3.5-inch to 5.25-inch adapter frame, verify with Seagate Technology that the drive can meet the shock and vibration specifications given herein while mounted in such an adapter frame. Adapter frames that are available may not have a mechanical structure capable of mounting the drive so that it can meet the shock and vibration specifications listed in this manual.

8.5 Grounding

Signal ground (PCBA) and HDA ground are connected together in the drive and cannot be separated by the user. The equipment in which the drive is mounted is connected directly to the HDA and PCBA with no electrically isolating shock mounts. If it is desired for the system chassis to not be connected to the HDA/PCBA ground, the systems integrator or user must provide a nonconductive (electrically isolating) method of mounting the drive in the host equipment.

Increased radiated emissions may result if you do not provide the maximum surface area ground connection between system ground and drive ground. This is the system designer's and integrator's responsibility.

9.0 Interface requirements

This section partially describes the interface requirements as implemented on Cheetah 15K.6 FC drives. Additional information is provided in the *Fibre Channel Interface Manual* (part number 100293070).

9.1 FC-AL features

This section lists the Fibre Channel-specific features supported by Cheetah 15K.6 FC drives.

9.1.1 Fibre Channel link service frames

Table 6 lists the link services supported by Cheetah 15K.6 FC drives.

Table 6: Link services supported

Type of frame	Link service
Basic link service frames	Abort Sequence (ABTS)
Basic link service reply frames	Basic_Accept (BA_ACC) Basic_Reject (BA_RJT)
Extended link service frames	N_Port Login (PLOGI) Fabric Login (FLOGI) Logout (LOGO) Process Login (PRLI) Process Logout (PRL0) Read Link Status (RLS) Fabric Address Notification (FAN) Port Discovery (PDISC) Address Discovery (ADISC) Third-party Process Logout (TRPLO)
Extended link service reply frames	Accept (ACC) Link Service Reject (LS_RJT)
Fibre Channel Services	Register FC-4 Types (RFT_ID)

9.1.2 Fibre Channel task management functions

Table 7 lists the Fibre Channel SCSI Fibre Channel Protocol (FC SCSI FCP) task management functions supported.

Table 7: Fibre Channel SCSI FCP task management functions

Task name	Supported
Terminate task	No
Clear ACA	Yes
Target reset	Yes
Clear task set	Yes
Abort task set	Yes

9.1.3 Fibre Channel task management responses

Table 8 lists the FC SCSI FCP response codes returned for task management functions supported.

Table 8: FC SCSI FCP response codes

Function name	Response code
Function complete	00
Function not supported	04
Function reject	05

9.1.4 Fibre Channel port login

Table 9 identifies the required content of the N_Port Login (PLOGI) payload from an initiator.

Table 9: N_Port login (PLOGI) payload

Bytes																	
0-15	03	00	00	00	09	09	BB	BB	CF	XX	FS	FS	XX	XX	XX	XX	Common
16-31	XX	XX	XX	XX	PN	PN	PN	PN	PN	PN	PN	PN	NN	NN	NN	NN	
32-35	NN	NN	NN	NN													
36-47					XX	XX	XX	XX	XX	XX	XX	XX	XX	XX	XX	XX	Class 1
48-51	XX	XX	XX	XX													
52-63					XX	XX	XX	XX	XX	XX	XX	XX	XX	XX	XX	XX	Class 2
64-67	XX	XX	XX	XX													
68-79					SO	SO	IC	IC	XX	XX	FS	FS	XX	CS	XX	XX	Class 3
80-83	OS	OS	XX	XX													
84-95					XX	XX	XX	XX	XX	XX	XX	XX	XX	XX	XX	XX	Reserved
96-99	XX	XX	XX	XX													
100-111					XX	XX	XX	XX	XX	XX	XX	XX	XX	XX	XX	XX	Vendor
112-115	XX	XX	XX	XX													Version

X Indicates a four-bit (hex) field is not checked.

x Indicates a single bit is not checked.

BB BB-Credit. This field is not checked. The FC-AL drive uses BB-Credit of zero (0).

CF Common features. This binary field selects the common features requested by the initiator login.

MSB	Continuously increasing offset	Must = 1
	Random relative offset	Not checked. Port Login Accept will return a 0—not supported.
	Valid version level	x
	N_Port/F_Port	Must = 0, N_Port
	Alternate credit model	Must = 1
	Other bits reserved	xxx XX

FS Receive buffer field size. The FS field in the common and Class 3 parameters is checked for the range 128 < FS < 2,112 and a multiple of four bytes. For multiple frame sequences, all frames but the last frame of the sequence must be this size. Only the receive buffer field size in the Class 3 parameters is used.

PN Port name (initiator's)—saved with the login parameters. If a change of the port name/AL_PA address association is detected during a Port DISCOVERY, and implicit logout occurs and the initiator returns a LS_RJT.

NN Node name. The node name is not checked or saved by the drive.

SO Service options Class 3 only.

MSB	Class valid	Must = 1
	Intermix	x
	Stacked connection req.	xx
	Sequential delivery	x
	Other bits reserved	xxx XX

IC Initiator control

MSB	XID reassign	xx
	Proc Assc	10 or 11 causes the login to be rejected. Other values are accepted.
	Other bits	XXX

CS Concurrent sequences Must be a value greater than 0.

OS Open sequences per exchange Must be a value greater than 0.

9.1.5 Fibre Channel port login accept

Table 10 identifies the N_Port Login access payload values.

Table 10: N_Port Login Accept (ACC) payload

Bytes																	
0-15	02	00	00	00	09	09	00	00	88	00	FS	FS	00	FF	00	01	Common
16-31	00	00	01	F4	2P	00	CC	CC	CC	UI	UI	UI	20	00	CC	CC	
32-35	CC	UI	UI	UI													
36-47					00	00	00	00	00	00	00	00	00	00	00	00	Class 1
48-51	00	00	00	00													
52-63					00	00	00	00	00	00	00	00	00	00	00	00	Class 2
64-67	00	00	00	00													
68-79					80	00	00	00	00	00	FS	FS	00	FF	00	00	Class 3
80-83	00	01	00	00													
84-95					00	00	00	00	00	00	00	00	00	00	00	00	Reserved
96-99	00	00	00	00													
100-111					00	00	00	00	00	00	00	00	00	00	00	00	Vendor -
112-115	00	00	00	00													Version

CC	Bytes (22, 23 and 24) and (30, 31 and 32) are currently factory set to 00 04 CF respectively (subject to change).															
FS	Receive buffer field size. The drive returns and uses the receive buffer size from the N_Port Login Class 3 receive buffer.															
UI	Unique identifier. This 24-bit field is uniquely assigned to the drive. This same UI appears in the Port Name and Node Name fields.															
P	Byte port identifier field.															
	0	P_LOGI received on Node.														
	1	P_LOGI received on Port A.														
	2	P_LOGI received on Port B.														

9.1.6 Fibre Channel Process Login

Table 11 lists the process login payload data.

Table 11: Process Login (PLRI) payload

Bytes																	
0-15	20	10	00	14	08	00	20	00	XX	XX	XX	XX	XX	XX	XX	XX	XX
16-19	00	00	00	22													

XX Indicates fields that are not used.

9.1.7 Fibre Channel Process Login Accept

Table 12 lists Cheetah 15K.6 FC process login accept payload data.

Table 12: Process Login Accept (ACC) payload

Bytes																
0-15	02	10	00	14	08	00	21	00	00	00	00	00	00	00	00	00
16-31	00	00	00	12												

9.1.8 Fibre Channel fabric login

Table 13 lists the fabric login payload from the drive.

Table 13: Fabric Login (FLOGI) payload

Bytes																	
0-15	04	00	00	00	09	09	00	00	08	00	08	40	00	00	00	00	Common
16-31	00	00	02	F4	2P	00	CC	CC	CC	UI	UI	UI	02	00	CC	CC	
32-35	CC	UI	UI	UI													
36-47					00	00	00	00	00	00	00	00	00	00	00	00	Class 1
48-51	00	00	00	00													
52-63					00	00	00	00	00	00	00	00	00	00	00	00	Class 2
64-67	00	00	00	00													
68-79					80	00	00	00	00	00	08	40	00	00	00	00	Class 3
80-83	00	00	00	00													
84-95					00	00	00	00	00	00	00	00	00	00	00	00	Reserved
96-99	00	00	00	00													
100-111					00	00	00	00	00	00	00	00	00	00	00	00	Vendor -
112-115	00	00	00	00													Version

CC Bytes (22, 23 and 24) and (30, 31 and 32) are currently factory set to 00 04 CF respectively (subject to change).

UI Unique identifier. This 24-bit field is uniquely assigned to the drive. This same UI appears in the Port Name and Node Name fields.

P Port identifier field.

1 FLOGI originated on Port A.

2 FLOGI originated on Port B.

9.1.9 Fibre Channel fabric accept login

Table 14 lists the required content of the Fabric Login Accept (ACC) payload from the fabric.

Table 14: Fabric Login Accept (ACC) payload

Bytes																	
0-15	02	00	00	00	09	09	BB	BB	CF	XX	FS	FS	R_	A_	T0	V_	Common
16-31	E_	D_	T0	V_	PN	PN	PN	PN	PN	PN	PN	PN	NN	NN	NN	NN	
32-35	NN	NN	NN	NN													
36-47					XX	XX	XX	XX	XX	XX	XX	XX	XX	XX	XX	XX	Class 1
48-51	XX	XX	XX	XX													
52-63					XX	XX	XX	XX	XX	XX	XX	XX	XX	XX	XX	XX	Class 2
64-67	XX	XX	XX	XX													
68-79					SO	SO	xx	xx	XX	XX	FS	FS	XX	xx	XX	XX	Class 3
80-83	OS	OS	XX	XX													
84-95					XX	XX	XX	XX	XX	XX	XX	XX	XX	XX	XX	XX	Reserved
96-99	XX	XX	XX	XX													
100-111					XX	XX	XX	XX	XX	XX	XX	XX	XX	XX	XX	XX	Vendor -
112-115	XX	XX	XX	XX													Version

X Indicates a four-bit (hex) field is not checked.

x Indicates a single bit is not checked.

BB BB-Credit. This field is not checked. The FC-AL drive uses BB-Credit of zero (0).

CF Common features. This binary field selects the common features requested by the fabric login.

MSB	Continuously increasing offset	x
	Random relative offset	x
	Valid version level	x
	N_Port/F_Port	Must = 1, F_Port
	Alternate credit model	Must = 1
	Other bits reserved	xxx XX

FS Receive buffer field size. The FS field in the common and Class 3 parameters is checked for the range 128 < FS < 2,112 and a multiple of four bytes. The receive buffer field size in the Class 3 parameters is used. The drive uses the lower FS of Fabric Login Accept or N_Port Login when sending frames to an initiator.

PN Port Name. The fabric port name is saved with the login parameters. If a change of the port name is detected during a FAN, an implicit logout occurs and a LS_RJT is returned to the fabric.

NN Node Name. The drive does not check or save the node name.

SO Service Options—Class 3 only.

MSB	Class valid	Must = 1
	Intermix	x
	Stacked connection req.	xx
	Sequential delivery	Must = 1
	Other bits reserved	xxx XX

9.1.10 Fibre Channel Arbitrated Loop options

Table 15 lists the FC-AL options supported by Cheetah 15K.6 FC drives.

Table 15: FC-AL options supported

Option	Supported
OPEN Half Duplex	Accepted from another device.
OPEN Full Duplex	Sent to open another device. Accepted from another device.
Private Loop	Yes
Public Loop	Yes
Old Port State	No
Loop Position	Yes
Loop Position Report	Yes

9.2 Dual port support

Cheetah 15K.6 FC drives have two independent FC-AL ports. These ports may be connected on independent loops or on the same loop. Port A and Port B may be connected in any order or combination.

- If both ports are connected on independent loops and hard addressing is used, the drive interface address is selected through the interface connector, both ports will seek the same loop address. If no conflict, both ports will have the same loop address.
- If both ports are connected in the same loop and hard addressing is used, at least one port will attempt taking a soft address to prevent an address conflict.

Note. When a Cheetah 15K.6 FC drive is connected in loops with previous Seagate FC drive products:

Barracuda 4LP FC (ST32171FC, ST34371FC, and ST34571FC)

Barracuda 9FC (ST19171FC)

Cheetah 4LP FC (ST34501FC)

Cheetah 9FC (ST19101FC)

the connection of Port A and B for these products must follow the requirements in their product manuals.

Subject to buffer availability, the Cheetah 15K.6 FC drives support:

- Concurrent port transfers—The drive supports receiving transfers on both ports at the same time when the ports are on independent loops.
- Full duplex—The drive supports sending FCP_Data, FCP_RSP, FCP_XFR_RDY and ELS transfers while receiving frames on both ports.

9.3 SCSI commands supported

Table 16 lists the SCSI commands supported by Cheetah 15K.6 FC drives.

Table 16: Supported commands

Command code	Supported [4]	Command name
00h	Y	Test unit ready
01h	Y	Rezero unit
03h	Y	Request sense
	Y	Extended sense
	Y	Field pointer bytes
	Y	Actual retry count bytes
04h	Y	Format unit [1]
07h	Y	Reassign blocks
08h	Y	Read
0Ah	Y	Write
0Bh	Y	Seek
12h	Y	Inquiry
	Y	Vital product data page (00h)
	Y	Unit serial number page (80h)
	Y	Implemented operating def. page (81h)
	Y	Device Identification page (83h)
	Y	Firmware numbers page (C0h)
	Y	Date code page (C1h)
	Y	Jumper settings page (C2h)
	Y	Device Behavior page (C3h)
15h	Y	Mode select (same pages as Mode Sense command shown below) [3]
16h	Y	Reserve
	N	3rd party reserved
	N	Extent reservation
17h	Y	Release
18h	N	Copy
1Ah	Y	Mode sense
	Y	Unit attention page (00h)
	Y	Error recovery page (01h)
	Y	Disconnect/reconnect control (page 02h)
	Y	Format page (03h)
	Y	Rigid disc drive geometry page (04h)

Table 16: Supported commands (continued)

Command code	Supported [4]	Command name
	Y	Verify error recovery page (07h)
	Y	Caching parameters page (08h)
	Y	Control mode page (0Ah)
	Y	Fibre Channel Interface Control page (19h)
	Y	Power control page (1Ah)
	Y	Information exceptions control page (1Ch)
	Y	Background Scan mode subpage (01h)
1Bh	Y	Start unit/stop unit
1Ch	Y	Receive diagnostic results
	Y	Supported diagnostics pages
	Y	Translate page
	Y	Enclosure services page
1Dh	Y	Send diagnostics page
	Y	Supported diagnostics pages
	Y	Translate page
25h	Y	Read capacity
28h	Y	Read extended
	Y	Disable page out
	Y	Force unit access
	N	Relative address
2Ah	Y	Write extended
	Y	Disable page out
	Y	Force unit access
	N	Relative address
2Bh	Y	Seek extended
2Eh	Y	Write and verify
	Y	Disable page out
	Y	Byte check
	N	Relative address
2Fh	Y	Verify
	Y	Disable page out
	Y	Byte check
	N	Relative address
30h	N	Search data high
31h	N	Search data equal

Table 16: Supported commands (continued)

Command code	Supported [4]	Command name
32h	N	Search data low
33h	N	Set limits
34h	N	Prefetch
35h	Y	Synchronize cache
36h	N	Lock-unlock-cache
37h	Y	Read defect data
39h	N	Compare
3Ah	N	Copy and verify
3Bh	Y	Write buffer
	Y	Write combined header and data mode (0)
	Y	Write data mode (2)
	N	Download microcode mode (4)
	Y	Download microcode and save modes (5)
	N	Download microcode with offsets mode (6)
	Y	Download microcode with offsets and save mode (7)
	Y	Firmware download option [2]
3Ch	Y	Read buffer
	Y	Read combined header and data mode (0)
	Y	Read data mode (2)
	Y	Read descriptor mode (3)
3Eh	Y	Read long
3Fh	Y	Write long
40h	N	Change definition
41h	Y	Write same
	N	PBdata
	N	LBdata
42-4Bh	N	Not used
4Ch	Y	Log Select
4Dh	Y	Log Sense
	Y	Support Log page (00h)
	Y	Write Error Counter page (02h)
	Y	Read Error Counter page (03h)
	N	Read Reverse Error Counter page (04h)
	Y	Verify Error Counter page (05h)
	Y	Non-medium Error Counter page (06h)

Table 16: Supported commands (continued)

Command code	Supported [4]	Command name
	Y	Temperature page (0Dh)
	N	Application Client page (0Fh)
	Y	Self Test Results page (10h)
	Y	Background Medium Scan page (15h)
	Y	Cache Statistics Counter page (37h)
	Y	Factory Log page (3Eh)
4E-4Fh	N	Not used
50h	N	XD write
51h	N	XP write
52h	N	XD read
53-54h	N	Not used
55h	Y	Mode Select (10) [3]
56h	Y	Reserved (10)
	Y	3rd party reserve
	N	Extent reservation
57h	Y	Released (10)
58-59h	N	Not used
5Ah	Y	Mode Sense (10) [3]
5B-5Dh	N	Not used
5E	A	Persistent reserve in
5F	A	Persistent reserve out
60-7Fh	N	Not used
80h	N	XD write extended
81h	N	Rebuild
82h	N	Regenerate
83-8Fh	N	Not used
A0h	Y	Report LUNS
C0-DFh	N	Not used
EO-FFh	N	Not used

[1] Cheetah 15K.6 FC drives can format to 512, 520, 524 or 528 bytes per logical block.

[2] **Warning.** Power loss during flash programming can result in firmware corruption. This usually makes the drive inoperable.

[3] Reference Mode Sense command 1Ah for mode pages supported.

[4] Y = Yes. Command is supported.

N = No. Command is not supported.

A = Support is available on special request.

9.3.1 Inquiry data

Table 17 lists the Inquiry command data that the drive should return to the initiator per the format given in the *Fibre Channel Interface Manual*.

Table 17: Cheetah 15K.6 FC inquiry data

Bytes	Data (hex)																
0-15	00	00	xx**	12	8B	00	PP	0A	53	45	41	47	41	54	45	20	Vendor ID
16-31	[53	54	33	34	35	30	38	35	36	46	43] ¹	20	20	20	20	20	Product ID
32-47	R#	R#	R#	R#	S#	S#	S#	S#	S#	S#	S#	S#	00	00	00	00	
48-63	00	00	00	00	00	00	00	00	00	00	00	00	00	00	00	00	
64-79	00	00	00	00	00	00	00	00	00	00	00	00	00	00	00	00	
80-95	00	00	00	00	00	00	00	00	00	00	00	00	00	00	00	00	
96-111	00	43	6F	70	79	72	69	67	68	74	20	28	63	29	20	32*	*Copyright
112-127	30*	30*	37*	20	53	65	61	67	61	74	65	20	41	6C	6C	20	notice
128-143	72	69	67	68	74	73	20	72	65	73	65	72	76	65	64	20	

* Copyright year (changes with actual year).

** SCSI Revision support. Refer to the SPC release documentation for definitions.

PP 50 = Inquiry data for an Inquiry command received on Port A.

70 = Inquiry data for an Inquiry command received on Port B.

R# Four ASCII digits representing the last four digits of the product firmware release number.

S# Eight ASCII digits representing the eight digits of the product serial number.

[] Bytes 18 through 26 reflect model of drive. The table above shows the hex values for Model ST3450856FC.

Refer to the values below for the values of bytes 18 through 26 of you particular model:

ST3300656FC 53 54 33 30 30 30 36 35 36 46 43

ST3146356FC 53 54 33 31 34 36 33 35 36 46 43

9.3.2 Mode Sense data

The Mode Sense command provides a way for the drive to report its operating parameters to the initiator. The drive maintains four sets of mode parameters:

1. Default values

Default values are hard-coded in the drive firmware stored in flash E-PROM (nonvolatile memory) on the drive's PCB. These default values can be changed only by downloading a complete set of new firmware into the flash E-PROM. An initiator can request and receive from the drive a list of default values and use those in a Mode Select command to set up new current and saved values, where the values are changeable.

2. Saved values

Saved values are stored on the drive's media using a Mode Select command. Only parameter values that are allowed to be changed can be changed by this method. Parameters in the saved values list that are not changeable by the Mode Select command get their values from default values storage.

When power is applied to the drive, it takes saved values from the media and stores them as current values in volatile memory. It is not possible to change the current values (or the saved values) with a Mode Select command before the drive achieves operating speed and is "ready." An attempt to do so results in a "Check Condition" status.

On drives requiring unique saved values, the required unique saved values are stored into the saved values storage location on the media prior to shipping the drive. Some drives may have unique firmware with unique default values also.

On standard OEM drives, the saved values are taken from the default values list and stored into the saved values storage location on the media prior to shipping.

3. Current values

Current values are volatile values being used by the drive to control its operation. A Mode Select command can be used to change the values identified as changeable values. Originally, current values are installed from saved or default values after a power on reset, hard reset, or Bus Device Reset message.

4. Changeable values

Changeable values form a bit mask, stored in nonvolatile memory, that dictates which of the current values and saved values can be changed by a Mode Select command. A one (1) indicates the value can be changed. A zero (0) indicates the value is not changeable. For example, in Table 18, refer to Mode page 81, in the row entitled "CHG." These are hex numbers representing the changeable values for Mode page 81. Note in columns 5 and 6 (bytes 04 and 05), there is 00h which indicates that in bytes 04 and 05 none of the bits are changeable. Note also that bytes 06, 07, 09, 10, and 11 are not changeable, because those fields are all zeros. In byte 02, hex value FF equates to the binary pattern 11111111. If there is a zero in any bit position in the field, it means that bit is not changeable. Since all of the bits in byte 02 are ones, all of these bits are changeable.

The changeable values list can only be changed by downloading new firmware into the flash E-PROM.

Note. Because there are often several different versions of drive control firmware in the total population of drives in the field, the Mode Sense values given in the following tables may not exactly match those of some drives.

The following tables list the values of the data bytes returned by the drive in response to the Mode Sense command pages for SCSI implementation (see the *Fibre Channel Interface Manual*).

Definitions:

SAV = Current saved value.

DEF = Default value. Standard OEM drives are shipped configured this way.

CHG = Changeable bits; indicates if default value is changeable.

Table 18: Mode Sense data saved, default and changeable values for ST3450856FC drives

MODE DATA HEADER:

00 be 00 10 00 00 00 08

MODE PAGES:

DEF 81 0a c0 0b ff 00 00 00 05 00 ff ff

CHG 81 0a ff ff 00 00 00 00 ff 00 ff ff

DEF 82 0e 80 80 00 00 00 00 00 00 01 3a 00 00 00 00

CHG 82 0e ff ff 00 00 00 00 00 00 ff ff 00 00 00 00

DEF 83 16 bb d0 00 00 00 00 03 80 04 c4 02 00 00 01 01 09 00 5f 40 00 00 00

CHG 83 16 00

DEF 84 16 02 57 08 08 00 00 00 00 00 00 00 00 00 00 00 00 00 00 3a a7 00 00

CHG 84 16 00

DEF 87 0a 00 0b ff 00 00 00 00 00 ff ff

CHG 87 0a 0f ff 00 00 00 00 00 00 ff ff

DEF 88 12 14 00 ff ff 00 00 ff ff ff ff 80 20 00 00 00 00 00 00

CHG 88 12 a5 00 00 00 ff ff ff ff 00 00 20 00 00 00 00 00 00 00

DEF 8a 0a 02 00 00 00 00 00 00 00 0e c4

CHG 8a 0a 03 f0 00 00 00 00 00 00 00 00

DEF 99 06 00 00 00 00 00 00

CHG 99 06 00 ff 00 00 00 00

DEF 9a 0a 00 02 00 00 00 05 00 00 00 04

CHG 9a 0a 00 03 ff ff ff ff 00 00 00 00

DEF 9c 0a 10 00 00 00 00 00 00 00 00 01

CHG 9c 0a 9d 0f ff ff ff ff ff ff ff

DEF 80 06 00 80 0f 00 00 00

CHG 80 06 b7 c0 0f 00 00 00

READ CAPACITY DATA:

READ BUFFER

0 1 2 3 4 5 6 7 8 9 A B C D E F ASCII

000000: 34 65 F8 6F 00 00 02 00 _ _ _ _ _ _ _ _ 4e.o....

Table 19: Mode Sense data default and changeable values for ST3300656FC drives

MODE DATA HEADER:

00 be 00 10 00 00 00 08

MODE PAGES:

DEF 81 0a c0 0b ff 00 00 00 05 00 ff ff
 CHG 81 0a ff ff 00 00 00 00 ff 00 ff ff

DEF 82 0e 80 80 00 00 00 00 00 00 01 3a 00 00 00 00
 CHG 82 0e ff ff 00 00 00 00 00 00 ff ff 00 00 00 00

DEF 83 16 bb d0 00 00 00 00 03 80 04 c4 02 00 00 01 01 09 00 5f 40 00 00 00
 CHG 83 16 00

DEF 84 16 02 57 08 06 00 00 00 00 00 00 00 00 00 00 00 00 00 00 3a a7 00 00
 CHG 84 16 00

DEF 87 0a 00 0b ff 00 00 00 00 00 ff ff
 CHG 87 0a 0f ff 00 00 00 00 00 ff ff

DEF 88 12 14 00 ff ff 00 00 ff ff ff ff 80 20 00 00 00 00 00 00
 CHG 88 12 a5 00 00 00 ff ff ff ff 00 00 20 00 00 00 00 00 00 00

DEF 8a 0a 02 00 00 00 00 00 00 09 9c
 CHG 8a 0a 03 f0 00 00 00 00 00 00 00

DEF 99 06 00 00 00 00 00
 CHG 99 06 00 ff 00 00 00

DEF 9a 0a 00 02 00 00 00 05 00 00 00 04
 CHG 9a 0a 00 03 ff ff ff ff 00 00 00 00

DEF 9c 0a 10 00 00 00 00 00 00 00 01
 CHG 9c 0a 9d 0f ff ff ff ff ff ff ff

DEF 80 06 00 80 0f 00 00 00
 CHG 80 06 b7 c0 0f 00 00 00

READ CAPACITY DATA:

READ BUFFER

	0	1	2	3	4	5	6	7	8	9	A	B	C	D	E	F	ASCII	
000000:	22	EC	B2	5B	00	00	02	00	__	__	__	__	__	__	__	__	__	"...[....

Table 20: Mode Sense data default and changeable values for ST3146356FC drives

MODE DATA HEADER:

00 be 00 10 00 00 00 08

MODE PAGES:

DEF 81 0a c0 0b ff 00 00 00 05 00 ff ff

CHG 81 0a ff ff 00 00 00 00 ff 00 ff ff

DEF 82 0e 80 80 00 00 00 00 00 00 01 3a 00 00 00 00

CHG 82 0e ff ff 00 00 00 00 00 00 ff ff 00 00 00 00

DEF 83 16 bb d0 00 00 00 00 03 80 04 c4 02 00 00 01 01 09 00 5f 40 00 00 00

CHG 83 16 00

DEF 84 16 02 57 08 03 00 00 00 00 00 00 00 00 00 00 00 00 00 00 3a a7 00 00

CHG 84 16 00

DEF 87 0a 00 0b ff 00 00 00 00 00 ff ff

CHG 87 0a 0f ff 00 00 00 00 00 00 ff ff

DEF 88 12 14 00 ff ff 00 00 ff ff ff ff 80 20 00 00 00 00 00 00

CHG 88 12 a5 00 00 00 ff ff ff ff 00 00 20 00 00 00 00 00 00 00

DEF 8a 0a 02 00 00 00 00 00 00 00 06 cc

CHG 8a 0a 03 f0 00 00 00 00 00 00 00 00

DEF 99 06 00 00 00 00 00 00

CHG 99 06 00 ff 00 00 00 00

DEF 9a 0a 00 02 00 00 00 05 00 00 00 04

CHG 9a 0a 00 03 ff ff ff ff 00 00 00 00

DEF 9c 0a 10 00 00 00 00 00 00 00 00 01

CHG 9c 0a 9d 0f ff ff ff ff ff ff ff

DEF 80 06 00 80 0f 00 00 00

CHG 80 06 b7 c0 0f 00 00 00

READ CAPACITY DATA:

READ BUFFER

0 1 2 3 4 5 6 7 8 9 A B C D E F ASCII

000000: 11 17 73 2F 00 00 02 00 _ _ _ _ _ _ _ _ ..s/....

9.4 Miscellaneous operating features and conditions

Table 21 lists various features and conditions. A “Y” in the support column indicates the feature or condition is supported. An “N” in the support column indicates the feature or condition is not supported.

Table 21: Miscellaneous features

Supported	Feature or condition
Y	FC-AL selective reset (LIP Reset)
N	Automatic contingent allegiance
N	Asynchronous event notification
N	Synchronized (locked) spindle operation
Y	Segmented caching
N	Zero latency read
Y	Queue tagging (up to 128 queue tags supported)
Y	Deferred error handling
Y	Parameter rounding (controlled by Round bit in Mode Select page 0)
Y	Reporting actual retry count in Extended Sense bytes 15, 16, and 17
N	Adaptive caching
Y	SMP = 1 in Mode Select command needed to save RPL and rotational offset bytes

Table 22: Miscellaneous status

Supported	Status
Y	Good
Y	Check condition
Y	Condition met/good
Y	Busy
Y	Intermediate/good
Y	Intermediate/condition met/good
Y	Reservation conflict
Y	Task set full
N	ACA active
N	ACA active, faulted initiator

9.5.2 Connector requirements

Table 23: Recommended mating SCA part numbers

Part description	Positions	Part number	Features
AMP Vertical (SCA sequence)	40	787317-1	With polarization
Berg	40	71781	With polarization
Methode	40	512-220-91-101N	With polarization
Molex	40	717431040	With polarization

The FC-AL SCA device connector is illustrated in Figure 13.

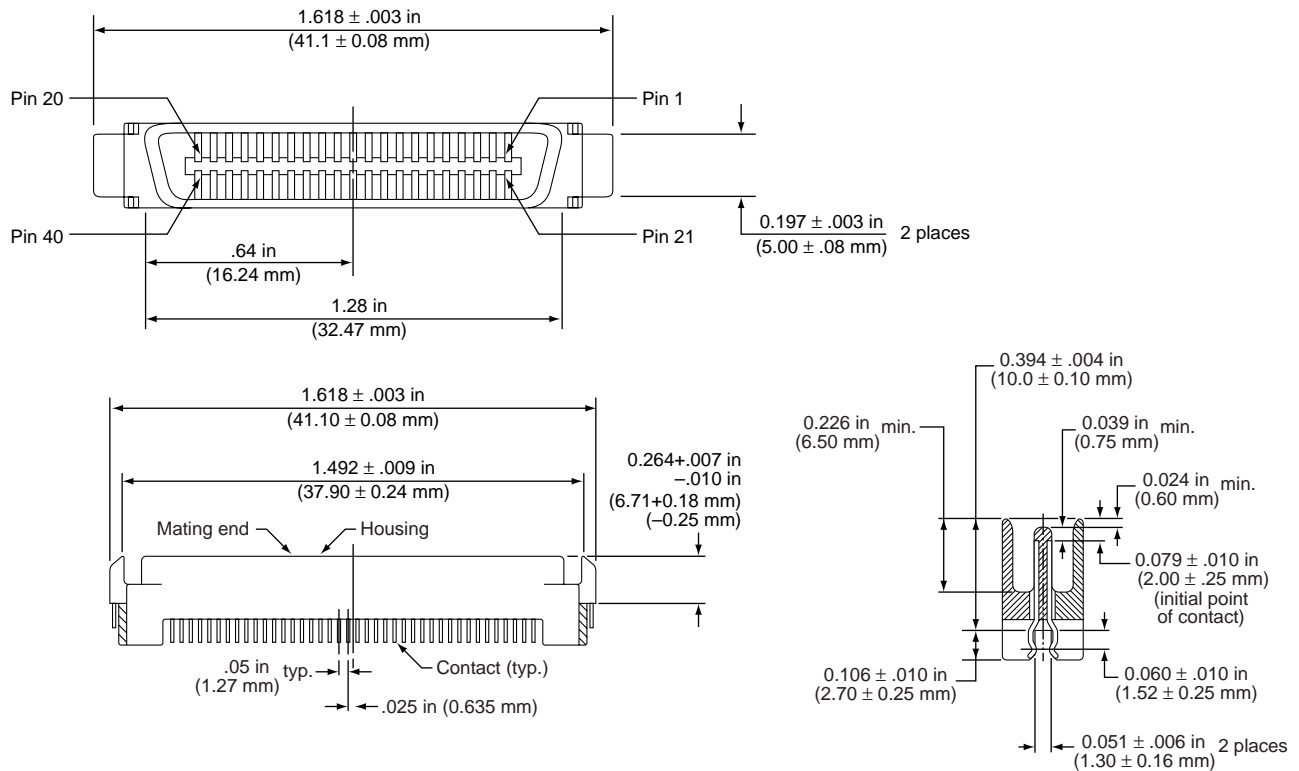

Figure 13. FC-AL SCA device connector dimensions

9.5.3 Electrical description

Fibre Channel drives use the FC-SCA connector for:

- DC power
- FC-AL interface
- Drive select (device identification)
- Option selection
- Enclosure Services interface

This 40-pin connector is designed to plug directly into a backpanel. External cables are not required.

9.5.4 Pin descriptions

This section provides a pin-out of the FC-SCA and a description of the functions provided by the pins.

Table 24: FC-SCA pin descriptions

Pin	Signal name	Signal type
1*	-EN bypass port A	Low Voltage TTL output
2*	12 Volts	
3*	12 Volts	
4*	12 Volts	
5*	-Parallel ESI	
6*	Ground ^[1]	
7*	Active LED out	Open collector out
8*	Reserved	
9*	Start_1 ^[2]	TTL input
10*	Start_2 ^[2]	TTL input
11*	-EN bypass port B	Low Voltage TTL output
12*	SEL_6	TTL input/output
13*	SEL_5	TTL input/output
14*	SEL_4	TTL input
15*	SEL_3	TTL input/output
16*	Fault LED out	Open collector out
17*	DEV_CTRL_CODE_2 ^[2]	TTL input
18*	DEV_CTRL_CODE_1 ^[2]	TTL input
19*	5 Volts	
20*	5 Volts	

Pin	Signal name	Signal type
21	12 Volts charge	
22	Ground	
23	Ground	
24*	+Port A_in	FC Diff. input pair
25*	-Port A_in	
26	Ground	
27*	+Port B_in	FC Diff. input pair
28*	-Port B_in	
29	Ground	
30*	+Port A_out	FC Diff. output pair
31*	-Port A_out	
32	Ground	
33*	+Port B_out	FC Diff. output pair
34*	-Port B_out	
35	Ground	
36	SEL_2	TTL input/output
37	SEL_1	TTL input/output
38	SEL_0	TTL input/output
39	DEV_CTRL_CODE_0 ^[2]	TTL input
40	5 Volts charge	

*Short pins in mating backpanel connector.

- [1] This pin may be connected to external logic to detect the presence of the drive. The drive connects this pin to the common ground.
- [2] Pins 9, 10, 17, 18, and 39 are option select pins and are tied high by the drive circuitry. The preferred electrical connection at the backplane is either open or grounded (open for the '1' setting, grounded for the '0' setting). Alternatively, these pins may be driven by a 3.3V logic device, pulled up to 3.3V through a pull-up resistor (recommended size of 10k ohm), or grounded through some other means.

9.5.5 FC-AL transmitters and receivers

A typical FC-AL differential copper transmitter and receiver pair is shown in Figure 14. The receiver is required to provide the AC coupling to eliminate ground shift noise.

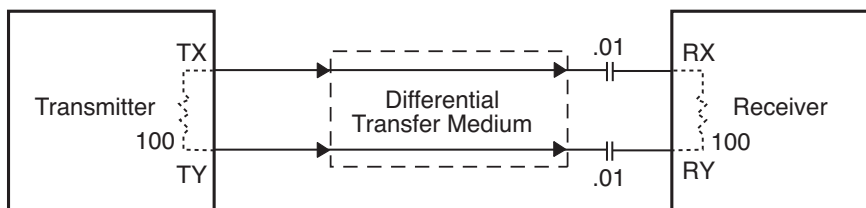

Figure 14. FC-AL transmitters and receivers

9.5.6 Power

Power is supplied through the FC-SCA with support for +5 volts and +12 volts. All of the voltage pins in the drive connector are the same length.

Four 12 volt pins provide +12 volt power to the drive. The current return for the +12 volt power supply is through the common ground pins. The supply current and return current must be distributed as evenly as possible among the pins. The maximum current typically occurs while the drive motor is starting.

Three 5 volt pins provide logic power to the drive. The current return for the +5 volt power supply is through the common ground pins. Distribute supply and return current as evenly as possible among the voltage and ground pins.

The mating connector pins use shorter contacts to achieve power surge reductions and to aid in “hot plugging” the drives. There are longer voltage contacts in the connector to enable the drive filter capacitors to charge. Current to the drive through the long charge pins is limited by the system in which the drive operates. Three of the +12 volt pins are shorter to allow capacitive pre-charging through the longer +12 volt charge pin. Two of the +5 volt pins are shorter to allow capacitive precharging through the longer +5 volt charge pin.

9.5.7 Fault LED Out

The Fault LED Out signal is driven by the drive when:

- the drive detects failure of both ports
- the drive detects an internal failure
- the drive receives the appropriate fault LED command from the host

The Fault LED Out signal is designed to pull down the cathode of an LED. The anode is attached to the proper +5 volt supply through an appropriate current-limiting resistor. The LED and the current-limiting resistor are external to the drive.

9.5.8 Active LED Out

The Active LED Out signal is driven by the drive as indicated in Table 25.

Table 25: Active LED Out conditions

Normal command activity	LED status
Spun down and no activity	Slow blink (20% on and 80% off a 2 sec cycle)
Spun down and activity (command executing)	On
Spun up and no activity	On
Spun up and activity (command executing)	Off
Spinning up or down	Blinks steadily (50% on and 50% off)
Format in progress, each cylinder change	Toggles on/off

The Active LED Out signal is designed to pull down the cathode of an LED. The anode is attached to the proper +5 volt supply through an appropriate current limiting resistor. The LED and the current limiting resistor are external to the drive.

9.5.9 Enable port bypass signals

The – Enable Bypass Port A (– EN BYP Port A) and – Enable Bypass Port B (– EN BYP Port B) signals control the port bypass circuits (PBC) located external to the disc drive. The PBC allows a loop to remain functional in the event of a drive failure or removal. When these signals are active, low, the PBC bypasses the drive on the associated port. When an Enable Bypass signal is active, the corresponding Port Bypass LED signal in connector J1 is driven low by the disc drive. A pull down resistor, 1K, located with the PBC should be used to insure the bypass is enabled if the disc drive is not installed.

The Enable Bypass signal is active under failing conditions within the drive, on detection of the Loop Port Bypass primitive sequence, or on removal of the drive. In the bypass state the drive continues to receive on the inbound fibre. Enable Bypass may be deactivated by detection of a Loop Port Enable primitive sequence if the drive has completed self-test and a hardware failure is not present.

Failure modes detected by the disc drive that will enable bypass include:

- Transmitter/receiver wrap test failure
- Loss of receive clock
- Loss of transmission clock
- Drive interface hardware error

9.5.10 Motor start controls

The drive's motor is started according to the Start_1 and Start_2 signals described in Table 26. The state of these signals can be wired into the backplane socket or driven by logic on the backplane.

Table 26: Motor start control signals

Case	Start_2	Start_1	Motor spin function
1	Low	Low	Motor spins up at DC power on.
2	High	Low	Motor spins up only when SCSI Start command is received.
3	Low	High	Motor spins up after a delay of 12 seconds times the modulo 8 value of the numeric SEL ID of the drive from DC power on.
4	High	High	The drive will not spin up.

9.5.11 SEL_6 through SEL_0 ID lines

The SEL_6 through SEL_0 ID lines determine drive address, and, optionally, for an Enclosure Services Interface. When the Parallel ESI line is high, the enclosure backpanel must provide address information on the SEL line. Refer to table 27 for a mapping of SEL to FC-AL physical addresses (AL_PA). You can think of the SEL lines as the equivalent of a backpanel logic plug. The drives do not provide pull up resistors on these lines. The backpanel is required to provide high and low inputs to the SEL_ID lines per the specifications in table 29 on page 73.

Note. Table 27 gives AL_PA values for each SEL value. The first entry in the table is SEL_ID 00. The last entry is SEL_ID 7D. SEL_ID 7E is AL_PA 00 which is not valid for an NL_Port, so is not included in the table. Also, SEL_ID 7Fh does not map to a valid AL_PA; however, this value signals the drive that physical addresses are not being assigned using the SEL lines and that a “soft” address will be determined by FC-AL loop initialization.

When the Parallel ESI line is low, the enclosure backpanel logic switches to ESI mode if supported. There are two modes of ESI, seven bits of enclosure status and a bidirectional mode. ESI support and the mode are determined by the drive using a discovery process. Refer to the *Fibre Channel Interface Manual* for a description of ESI operation.

9.5.11.1 Parallel Enclosure Services Interface (ESI)

The parallel ESI line is an output from the drive. This line provides the enclosure with an indication of the present function of the SEL lines. A high level, the default state, indicates the drive requires address information on the SEL lines. A low level indicates the drive is attempting an ESI transfer. The enclosure may not support ESI on any or all drive locations. It may only support the address function. Support of ESI is discovered by the drive. Refer to the *Fibre Channel Interface Manual* for a description of ESI operations.

Table 27: Arbitrated loop physical address (AL_PA) values

AL_PA (hex)	SEL ID (hex)	Setting (dec)
EF	00	00
E8	01	01
E4	02	02
E2	03	03
E1	04	04
E0	05	05
DC	06	06
DA	07	07
D9	08	08
D6	09	09
D5	0A	10
D4	0B	11
D3	0C	12
D2	0D	13
D1	0E	14
CE	0F	15
CD	10	16
CC	11	17
CB	12	18
CA	13	19
C9	14	20
C7	15	21
C6	16	22
C5	17	23
C3	18	24
BC	19	25
BA	1A	26
B9	1B	27
B6	1C	28
B5	1D	29
B4	1E	30
B3	1F	31
B2	20	32
B1	21	33
AE	22	34
AD	23	35
AC	24	36
AB	25	37
AA	26	38
A9	27	39
A7	28	40
A6	29	41
A5	2A	42

AL_PA (hex)	SEL ID (hex)	Setting (dec)
A3	2B	43
9F	2C	44
9E	2D	45
9D	2E	46
9B	2F	47
98	30	48
97	31	49
90	32	50
8F	33	51
88	34	52
84	35	53
82	36	54
81	37	55
80	38	56
7C	39	57
7A	3A	58
79	3B	59
76	3C	60
75	3D	61
74	3E	62
73	3F	63
72	40	64
71	41	65
6E	42	66
6D	43	67
6C	44	68
6B	45	69
6A	46	70
69	47	71
67	48	72
66	49	73
65	4A	74
63	4B	75
5C	4C	76
5A	4D	77
59	4E	78
56	4F	79
55	50	80
54	51	81
53	52	82
52	53	83
51	54	84
4E	55	85

AL_PA (hex)	SEL ID (hex)	Setting (dec)
4D	56	86
4C	57	87
4B	58	88
4A	59	89
49	5A	90
47	5B	91
46	5C	92
45	5D	93
43	5E	94
3c	5F	95
3A	60	96
39	61	97
36	62	98
35	63	99
34	64	100
33	65	101
32	66	102
31	67	103
2E	68	104
2D	69	105
2C	6A	106
2B	6B	107
2A	6C	108
29	6D	109
27	6E	110
26	6F	111
25	70	112
23	71	113
1F	72	114
1E	73	115
1D	74	116
1B	75	117
18	76	118
17	77	119
10	78	120
0F	79	121
08	7A	122
04	7B	123
02	7C	124
01	7D	125

9.5.12 Device control codes

The drive inputs a Device Control Code on the DEV_CTRL_CODE lines at power up to determine the link rate on the Fibre Channel ports. Both ports run at the same rate. If the backpanel does not connect to these lines, the drive has 10K ohm pull up resistors that default the device control code to 7 (1.0625 GHz). Table lists the supported codes.

Table 28: Device control code values

2 (pin 17)	1 (pin 18)	0 (pin 39)	Definition
0	0	0	Reserved for power failure warning.
0	0	1	Reserved for auto negotiation of link rate.
0	1	0	Reserved.
0	1	1	Reserved.
1	0	0	Reserved.
1	0	1	4.250 GHz operation on both ports.
1	1	0	2.125 GHz operation on both ports.
1	1	1	1.0625 GHz operation on both ports.

9.6 Signal characteristics

This section describes the electrical signal characteristics of the drive's input and output signals. See Table 24 on page 68 for signal type and signal name information.

9.6.1 TTL input characteristics

Table 29 provides the TTL characteristics.

Table 29: TTL characteristics

State	Voltage	Current
Input high	$1.9 < V_{IH} < 5.5V$	$I_{IH} = \pm 500nA \text{ max.}$
Input low	$-0.5V < V_{IL} < 0.9V$	$I_{OL} = \pm 500nA \text{ max.}$
Output high (-EN Bypass A, B)	$2.4 < V_{OH} < 5.25V$	$I_{OH} < -3mA$
Output low (-EN Bypass A, B)	$V_{OL} < 0.5V$	$I_{OL} < 3mA$
Output high (-Parallel ESI)	$2.4 < V_{OH} < 0.9 V_{CC}$ $V_{OH} > 0.9V_{CC}$	$I_{OH} < -2.4mA$ $I_{OH} < -500\mu A$
Output low (-Parallel ESI)	$0 < V_{OL} < .45V$	$I_{OL} < 2.4mA$
Output high (all other outputs)	$2.4 < V_{OH} < 0.9 V_{CC}$ $V_{OH} > 0.9V_{CC}$	$I_{OH} < -1.6mA$ $I_{OH} < -500\mu A$
Output low (all other outputs)	$0 < V_{OL} < .45V$	$I_{OL} < 1.6mA$

9.6.2 LED driver signals

Fault and Active LED signals are located in the FC-SCA connector (J1). See Table 30 for the output characteristics of the LED drive signals.

Table 30: LED drive signal

State	Current drive available	Output voltage
LED off, high	$0 < I_{OH} < 100\mu A$	
LED on, low	$I_{OL} < -30 \text{ mA}$	$0 < V_{OL} < 0.8V$

9.6.3 FC Differential output

The serial output signal voltage characteristics are provided in Table 31. The outputs are not AC coupled in order to deliver maximum signal without rise and fall time degradation. You must AC couple the receiver to isolate potentially different DC characteristics of the outputs and the receiver.

Table 31: FC Differential output characteristics

Description	Parameter	Notes
Serial output voltage swing	$600 < V_{out} < 1300 \text{ mV}$	Centered at 1.32V

Figure 15 provides the data output valid eye diagram relative to the bit cell time.

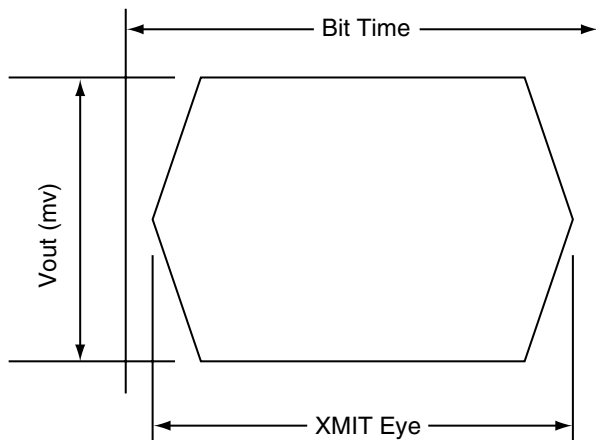

Figure 15. Transmit eye diagram

9.6.4 FC Differential input

The serial input signal voltage characteristics are provided in Table 32.

Table 32: FC Differential input characteristics

Description	Parameter	Notes
Serial input voltage swing	$200 < V_{in} < 1.300 \text{ mV}$	AC coupled

Figure 16 provides the data valid eye diagram for typical and minimum requirements to recover data at the specified interface error rate. The inputs are AC coupled on the drive.

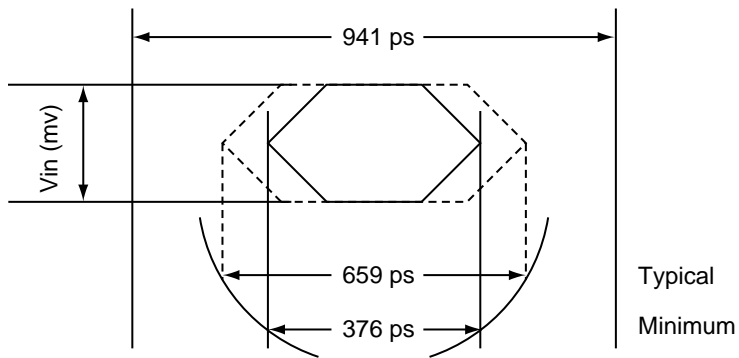

Figure 16. Receive eye diagram

Table 33: Eye diagram data values

		Link rate		
		1 GHz	2 GHz	4 GHz
Bit time		941 ps	470 ps	235 ps
XMIT eye		725 ps min.	315 ps min.	$158^1/113^2$
RCV eye	Typical	659 ps	305 ps	145 ps
	Minimum	395 ps	226 ps	113 ps

1. Short Ideal load.
2. End of compliance channel.

10.0 Seagate Technology support services

Internet

For information regarding Seagate products and services, visit www.seagate.com. Worldwide support is available 24 hours daily by email for your questions.

Presales Support:

Presales@Seagate.com

Technical Support:

DiscSupport@Seagate.com

Warranty Support:

<http://www.seagate.com/support/service/index.html>

mySeagate

my.seagate.com is the industry's first Web portal designed specifically for OEMs and distributors. It provides self-service access to critical applications, personalized content and the tools that allow our partners to manage their Seagate account functions. Submit pricing requests, orders and returns through a single, password-protected Web interface-anytime, anywhere in the world.

spp.seagate.com

spp.seagate.com supports Seagate resellers with product information, program benefits and sales tools. You may register for customized communications that are not available on the web. These communications contain product launch, EOL, pricing, promotions and other channel-related information. To learn more about the benefits or to register, go to spp.seagate.com, any time, from anywhere in the world.

Seagate Service Centers

Presales Support

Our Presales Support staff can help you determine which Seagate products are best suited for your specific application or computer system, as well as product availability and compatibility.

Technical Support

Seagate technical support is available to assist you online at support.seagate.com or through one of our call centers. Have your system configuration information and your "ST" model number available.

SeaTDD™ (+1-405-324-3655) is a telecommunications device for the deaf (TDD). You can send questions or comments 24 hours daily and exchange messages with a technical support specialist during normal business hours for the call center in your region.

Customer Service Operations

Warranty Service

Seagate offers worldwide customer support for Seagate products. Seagate distributors, OEMs and other direct customers should contact their Seagate Customer Service Operations (CSO) representative for warranty-related issues. Resellers or end users of drive products should contact their place of purchase or Seagate warranty service for assistance. Have your serial number and model or part number available.

Data Recovery Services

Seagate offers data recovery services for all formats and all brands of storage media. Our data recovery services labs are currently located throughout the world. . Additional information, including an online request form and data loss prevention resources, is available at <http://services.seagate.com/index.aspx>

Authorized Service Centers

Seagate Service Centers are available on a global basis for the return of defective products. Contact your customer support representative for the location nearest you.

USA/Canada/Latin America support services

For an extensive list of telephone numbers to technical support, presales and warranty service in USA/Canada/Latin America, including business hours, go to the "Contact Us" page on www.seagate.com.

Global Customer Support

Data Recovery Services

Call Center

USA, Canada,
and Mexico

Toll-free

1-800-475-01435

Direct dial

+1-905-474-2162

FAX

1-800-475-0158

+1-905-474-2459

Europe, the Middle East and Africa Support Services

For an extensive list of telephone numbers to technical support, presales and warranty service in Europe, the Middle East and Africa, go to the "Contact Us" page on www.seagate.com.

Asia/Pacific Support Services

For an extensive list of telephone numbers to technical support, presales and warranty service in Asia/Pacific, go to the "Contact Us" page on www.seagate.com.

Index

Numerics

- 12 volt
 - pins 69
- 3rd party reserve command 59
- 5 volt pins 69

A

- Abort Sequence (ABTS) 49
- abort task set function 50
- AC coupling 68
- AC power requirements 23
- ACA active status 65
- ACA active, faulted initiator status 65
- Accept (ACC) 49
- acoustics 35
- active LED Out signal 70
- Actual retry count bytes command 56
- actuator
 - assembly design 7
- adaptive caching 65
- Address Discovery (ADISC) 49
- addresses 66
- AFR 15
- air cleanliness 35
- air flow 46
 - illustrated 46
- Alternate credit model 51, 54
- altitude 32
- ambient 32
- Annualized Failure Rates (AFR) 16
- ANSI documents
 - fibre channel 5
 - SCSI 5
- arbitrated loop physical address (AL_PA) 45
- arbitration 45
- asynchronous event notification 65
- audible noise 3
- auto negotiation of link rate 73
- auto write and read reallocation
 - programmable 8
- automatic contingent allegiance 65
- average idle current 23, 24
- average rotational latency 11

B

- Background Media Scan 41
- backpanel 67
- backplane 70
- basic link service frames 49
- Basic_Accept (BA_ACC) 49
- Basic_Reject (BA_RJT) 49

- BB 51, 54
- BB-Credit 51, 54
- BMS 41
- buffer
 - data 8
 - space 13
- busy status 65
- bypass circuit 16
- Byte check command 57

C

- cache operation 13
- cache segments 13
- Caching parameters page (08h) command 57
- caching write data 13
- Canadian Department of Communications 3
- capacity
 - unformatted 11
- capacity, drive, programmable 9
- CC 52, 53
- CF 51, 54
- Change definition command 58
- character sync 16
- charge pins 69
- check condition status 65
- Class 3 parameters 51, 54
- class B limit 3
- Class valid 51, 54
- clear ACA function 50
- clear task set function 50
- commands supported 56
- Common features 51, 54
- Company ID 52, 53
- Compare command 58
- Concurrent sequences 51
- condensation 32
- condition met/good status 65
- connector
 - illustrated 67
 - requirements 67
- continuous vibration 35
- Continuously increasing offset 51, 54
- control code values 73
- Control mode page (0Ah) command 57
- cooling 45
- Copy and verify command 58
- Copy command 56
- CRC 16
 - error 16
- CS 51
- Current profiles 25
- customer service 21

D

- DAR 42
- data heads
 - read/write 11
- data rate
 - internal 11
- data transfer rate 12
- data valid eye 75
- Date code page command 56
- DC power 67
 - requirements 23
- defect and error management 39
- defects 39
- Deferred Auto-Reallocation 42
- deferred error handling 65
- description 7
- DEV_CTRL_CODE 73
- Device Behavior page command 56
- device control code values 73
- Device Identification page command 56
- device selection IDs 45
- devices 45
- dimensions 37
- Disable page out command 57
- disc rotation speed 11
- Disconnect/reconnect control (page 02h) command 56
- Download microcode and save modes (5) 58
- Download microcode mode (4) 58
- Download microcode with offsets and save mode (7) 58
- Download microcode with offsets mode (6) 58
- drive 35
- drive capacity
 - programmable 9
- drive characteristics 11
- drive ID 45
- drive ID/option select headers 45
- drive mounting 37, 46
- drive orientation 45
- drive select 67
- driver signals 74
- drivers and receivers 8
- dual port support 55

E

- electrical
 - description of connector 67
 - signal characteristics 73
 - specifications 23
- electromagnetic compatibility 3
- electromagnetic susceptibility 36
- EMI requirements 3
- enable bypass

- port A 70
- port B 70
- signal 70
- state 16
- Enclosure Services interface 67
- Enclosure services page command 57
- environmental
 - limits 31
 - requirements 15
- environmental control 35
- error
 - detection mechanisms, FC 16
 - management 39
 - rates 15
- error correction code
 - 96-bit Reed-Solomon 8
- Error recovery page (01h) command 56
- errors 39
- extended link service
 - frames 49
 - reply frames 49
- Extended sense command 56
- Extent reservation command 59

F

- fabric 54
- Fabric Address Notification (FAN) 49
- Fabric Login (FLOGI) 49
- FAN 54
- fault LED out signal 69
- FC differential input 74
- FC-AL
 - document 5
 - interface 45, 67
 - options supported 55
 - physical interface 66
 - SCA device connector, illustrated 67
 - selective reset 65
- FCC rules and regulations 3
- FCP
 - for SCSI, document 5
 - response codes 50
 - task management functions 50
- FC-PH document 5
- features 8
 - interface 49
- Fibre Channel documents 5
- Fibre Channel Interface Control page (19h) 57
- Fibre Channel Interface Manual 1, 3
- Fibre Channel Services 49
- Field pointer bytes command 56
- firmware 8
 - corruption 59
- Firmware download option command 58
- Firmware numbers page command 56

- flawed sector reallocation 8
- FLOGI
 - received on Port A 53
 - received on Port B 53
- Force unit access command 57
- form factor 8
- format 45
- Format command execution time 12
- Format page (03h) command 56
- Format unit command 56
- front panel 37
- FS 51, 52, 54
- function
 - complete, code 00 50
 - not supported, code 05 50
 - reject, code 04 50

G

- Good status 65
- gradient 32
- ground shift noise 68
- grounding 47

H

- hard assigned arbitrated loop physical address (AL_PA) 45
- HDA 47
- heads
 - read/write data 11
- heat removal 45
- host equipment 47
- hot plugging the drive 16
- humidity 32
- humidity limits 31

I

- IC 51
- ID and configuration options 8
- Idle Read After Write 43
- Implemented operating def. page command 56
- Information exceptions control page (1Ch) command 57
- Initiator control 51
- Inquiry command 56
- inquiry data 60
- installation 45
- interface 45
 - commands supported 56
 - description 66
 - error rate 15
 - errors 16
 - illustrated 66
 - physical 66
 - requirements 49
- intermediate/condition met/good status 65
- intermediate/good status 65
- Intermix 51, 54
- internal data rate 11
- internal defects/errors 39
- internal drive characteristics 11
- IRAW 43

J

- J1 connector 45
- Jumper settings page command 56
- jumpers 45

L

- latency
 - average rotational 11, 12
- LBdata 58
- LED driver signals 74
- Link Service Reject (LS_RJT) 49
- link services supported 49
- Lock-unlock-cache command 58
- Log select command 58
- Log sense command 58
- logic power 69
- logical block address 13
- logical block reallocation scheme 8
- logical block size 8, 12
- logical segments 13
- Logout (LOGO) 49
- loop 66, 70
 - disruption 16
 - initialization 45
- loop position
 - FC-AL options 55
- loop position report
 - FC-AL options 55
- LS_RJT 51, 54
- LSI circuitry 9

M

- maintenance 15
- maximum delayed motor start 23, 24
- maximum start current 23, 24
- mean time between failure (MTBF) 16
- media description 8
- Media Pre-Scan 42
- miscellaneous feature support
 - Adaptive caching 65
 - Asynchronous event notification 65
 - Automatic contingent allegiance 65
 - Deferred error handling 65
 - FC-AL selective reset 65
 - Parameter rounding 65
 - Queue tagging 65

- Reporting actual retry count 65
- Segmented caching 65
- SMP = 1 in Mode Select command 65
- Synchronized (locked) spindle operation 65
- Zero latency read 65
- miscellaneous status support
 - ACA active 65
 - ACA active, faulted initiator 65
 - Busy 65
 - Check condition 65
 - Condition met/good 65
 - Good 65
 - Intermediate/condition met/good 65
 - Intermediate/good 65
 - Reservation conflict 65
 - Task set full 65
- miscorrected media data 15
- Mode select
 - (10) command 59
 - command 56
- Mode sense
 - (10) command 59
 - command 56
 - data, table 60, 62
- monitoring state 16
- motor start
 - controls 70
 - option 12
- mounting 46
 - holes 46
 - orientations 45
- mounting configuration 37
- mounting configuration dimensions 37
- MTBF 16

N

- N_Port Login (PLOGI) 49
 - payload 51
 - payload values 52
- NN 51, 54
- Node Name 54
- Node name 51
- noise
 - audible 3
- noise immunity 25
- non-operating 32, 33, 35
 - temperature 32
- non-operating vibration 35

O

- office environment 35
- old port state
 - FC-AL options 55
- OPEN Full Duplex

- FC-AL options 55
- OPEN half duplex
 - FC-AL options 55
- Open sequences per exchange 51
- operating 32, 35
- option configurations 45
- option selection 67
- options 9, 55
- orientation 32
- OS 51
- out-of-plane distortion 46

P

- P_LOGI
 - received on Port A 52
 - received on Port B 52
- package size 33
- package test specification 5
- packaged 33
- parameter rounding 65
- pass-through state 16
- PBC 66, 70
- PBdata 58
- PCBA 47
- peak bits per inch 11
- peak operating current 23, 24
- peak-to-peak measurements 25
- performance characteristics
 - detailed 11
 - general 12
- performance degradation 33
- performance highlights 9
- physical damage 35
- physical interface 66
 - description 66
- physical specifications 23
- PI 52, 53
- pin descriptions 67
- PN 51, 54
- port bypass circuit 16, 17, 66, 70
- Port DIScovery 51
- Port Discovery (PDISC) 49
- port identifier field 52, 53
- port login 51
 - accept 52
- Port Name 54
- Port name (initiator's) 51
- power 69
 - dissipation 29
 - requirements, AC 23
 - requirements, DC 23
 - sequencing 25
- Power control page (1Ah) command 57
- power distribution 3
- power failure warning 73

- Prefetch command 58
- prefetch/multi-segmented cache control 12
- preventive maintenance 15
- private loop
 - FC-AL options 55
- Proc Assc 51
- Process Accept (ACC) 53
- Process Login (PRLI) 49, 52
- Process Login Accept (ACC) payload 53
- process login payload data 52
- Process Logout (PRLO) 49
- programmable drive capacity 9
- public loop
 - FC-AL options 55
- pull down resistor 70

Q

- queue tagging 65

R

- radio interference regulations 3
- Random relative offset 51, 54
- RCD bit 13
- Read buffer command 58
- Read capacity command 57
- Read combined header and data mode (0) 58
- Read command 56
- Read data mode (2) 58
- Read defect data command 58
- Read descriptor mode (3) 58
- read error rates 15, 39
- Read extended command 57
- Read Link Status (RLS) 49
- Read long command 58
- read/write data heads 11
- Reassign blocks command 56
- Receive buffer field size 51, 54
- receive buffer field size 52
- Receive diagnostic results command 57
- receive eye
 - diagram 75
- receivers 68
- recommended mounting 34
- Recoverable Errors 15
- recovered media data 15
- reference
 - documents 5
- Regenerate command 59
- Register FC-4 Types (RFT_ID) 49
- Relative address command 57
- relative humidity 32
- Release command 56
- Released (10) command 59
- reliability 9

- specifications 15
- reliability and service 16
- repair and return information 21
- reporting actual retry count 65
- Request sense command 56
- reservation conflict status 65
- Reserve command 56
- Reserved (10) command 59
- resonance 32
- return information 21
- Rezero unit command 56
- Rigid disc drive geometry page
 - command 56
- rotation speed 11
- running disparity 16

S

- safety 3
- SCA part numbers 67
- SCSI interface
 - commands supported 56
- Search data
 - equal command 57
 - high command 57
 - low command 58
- Seek command 56
- seek error
 - defined 16
 - rate 15
- Seek extended command 57
- seek performance characteristics 11
- seek time
 - average typical 11
 - full stroke typical 11
 - single track typical 11
- segmented caching 65
- SEL ID 45
 - lines 71
 - standard feature 8
- Self-Monitoring Analysis and Reporting Technology 9, 17
- Send diagnostics page command 57
- Sequential delivery 51, 54
- Service Options 54
- Service options 51
- Set limits command 58
- shielding 3
- shipping 21
- shipping container 32
- shock 32, 33
 - and vibration 32
- shock mount 47
- signal
 - characteristics 73
 - LED driver 74

- single-unit shipping pack kit 10
- SMART 9, 17
- SMP = 1 in Mode Select command 65
- SO 51, 54
- spindle brake 8
- Stacked connection req. 51, 54
- standards 3
- Start unit/stop unit command 57
- start/stop time 12
- support services 77
- Supported diagnostics pages command 57
- surface stiffness
 - allowable for non-flat surface 46
- switches 45
- Synchronize cache command 58
- synchronized spindle
 - operation 65
- system chassis 47

T

- target reset function 50
- task management functions 50
 - Abort task set 50
 - Clear ACA 50
 - Clear task set 50
 - Target reset 50
 - terminate task 50
- task management response codes 50
 - Function complete 00 50
 - Function not supported 05 50
 - Function reject 04 50
- task set full status 65
- technical support services 77
- temperature 31, 45
 - limits 31
 - non-operating 32
 - regulation 3
 - See also* cooling
- terminate task function 50
- terminators 45
- Test unit ready command 56
- Third-party Process Logout (TRPLO) 49
- tracks per inch 11
- Translate page command 57
- transmit eye diagram 74
- transmitters 68
- transporting the drive 21
- TTL input characteristics 73

U

- UI 52, 53
- unformatted 9
- unique identifier 52, 53
- Unit attention page (00h) command 56

- Unit serial number page command 56
- Unrecoverable Errors 15
- unrecovered media data 15

V

- Valid version level 51, 54
- Verify command 57
- Verify error recovery page (07h) command 57
- vibration 32, 35
- Vital product data page command 56

W

- warranty 21
- word sync 16
- Write and verify command 57
- Write buffer command 58
- Write combined header and data mode (0) 58
- Write command 56
- Write data mode (2) 58
- Write extended command 57
- Write long command 58
- Write same command 58

X

- XD read 59
- XD write 59
- XD write extended command 59
- XID reassign 51
- XP write 59

Z

- zero latency read 65
- zone bit recording (ZBR) 8



Seagate Technology LLC
920 Disc Drive, Scotts Valley, California 95066-4544, USA
Publication Number: 100465943, Rev. A, Printed in USA