



.....
ST9190 Family:
.....

ST9190AG
.....

ST9140AG
.....

AT Interface Drives
.....

Product Manual
.....

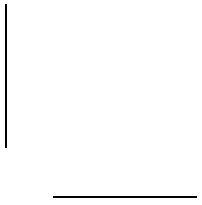
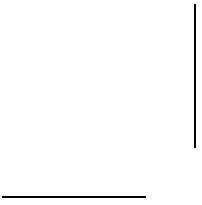

.....
ST9190 Family:
.....

ST9190AG
.....

ST9140AG
.....

AT Interface Drives
.....

Product Manual
.....



©1994 Seagate Technology, Inc. All rights reserved

Publication Number: 36230-001, Rev. B
July 1994

Seagate®, Seagate Technology® and the Seagate logo are registered trademarks of Seagate Technology, Inc. Other product names are registered trademarks or trademarks of their owners.

Seagate reserves the right to change, without notice, product offerings or specifications. No part of this publication may be reproduced in any form without written permission from Seagate Technology, Inc.

Contents

1.0 Drive specifications	1
1.1 Formatted capacity	1
1.2 Physical organization	1
1.3 Logical organization	1
1.4 Default logical geometry	1
1.5 Functional specifications	2
1.6 Physical dimensions	2
1.7 Seek time	2
1.8 Spinup time	3
1.9 Reliability	3
1.10 Environment	4
1.10.1 Acoustics	4
1.10.2 Ambient temperature	4
1.10.3 Temperature gradient	4
1.10.4 Relative humidity	4
1.10.5 Altitude	4
1.10.6 Shock	5
1.10.7 Vibration	5
1.11 Power specifications	6
1.11.1 Power-management modes	6
1.11.2 Power consumption	8
1.11.3 Conducted Noise	9
1.12 UL/CSA listing	9
1.13 FCC verification	9
2.0 Drive mounting and configuration	11
2.1 Handling and static-discharge precautions	11
2.2 Mounting the ST9190 family drives	11
2.3 Master/slave configuration	13

2.4 Remote LED	15
2.5 ECC testing	15
3.0 ATA interface	17
3.1 ATA interface connector	17
3.2 ATA interface signals and connector pins	18
3.2.1 AT bus signal levels	19
3.3 ATA interface commands	20
3.3.1 Identify Drive command	22
3.3.2 Set Features command	25

Figures

Figure 1. Typical current profile for the ST9190 family drives	8
Figure 2. Mounting dimensions for the ST9190 family drives	12
Figure 3. Connector setup for the ST9190 family drives	14
Figure 4. ATA interface connector for the ST9190 family drives . .	17

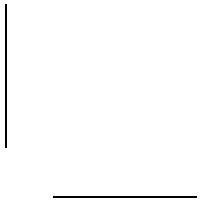
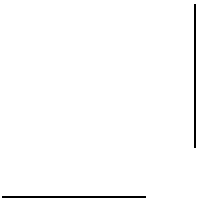

1.0 Drive specifications

1.1 Formatted capacity

	ST9190AG	ST9140AG
Guaranteed Mbytes (1 Mbyte = 10 ⁶ bytes)	171.6	127.9
Guaranteed sectors	335,232	249,900
Bytes per sector	512	512

1.2 Physical organization

	ST9190AG	ST9140AG
Read/Write heads	4	4
Discs	2	2

1.3 Logical organization

The ST9190 family drives support all head, cylinder and sector geometries, subject to the maximums specified below, and to the following condition:

$$(\text{sectors}) \times (\text{heads}) \times (\text{cylinders}) \leq \text{total sectors per drive}$$

	ST9190AG	ST9140AG
Sectors per track (max)	64	64
Read/Write heads (max)	16	16
Cylinders (max)	1,024	1,024

1.4 Default logical geometry

	ST9190AG	ST9140AG
Sectors per track	24	17
Read/Write heads	16	15
Cylinders	873	980

1.5 Functional specifications

Interface	AT
Recording method	RLL (1,7)
Recording density (BPI)	57,120
Flux density (FCI)	42,840
Track density (TPI)	2,760
Spindle speed (RPM) ($\pm 0.5\%$)	3,546
Internal data transfer rate (Mbits per sec max—ZBR)	22.13
I/O data transfer rate (Mbytes per sec max)	5.2
Interleave	1:1
Cache buffer (Kbytes)	120

1.6 Physical dimensions

	ST9190AG	ST9140AG
Height (max) inches (mm)	0.504 (12.80)	0.504 (12.80)
Width (max) inches (mm)	2.760 (70.10)	2.760 (70.10)
Depth (max) inches* (mm)	4.010 (101.85)	4.010 (101.85)
Weight (typical) ounces (kg)	5.7 (0.161)	5.7 (0.161)

* Excludes I/O connector pins, which may extend up to 0.010 inches beyond the edge of the head/disc assembly.

1.7 Seek time

All seek times are measured using a 25-MHz 486 AT computer (or faster) with a 8.3-MHz I/O bus. The measurements are taken with nominal power at sea level and 25°C ambient temperature. The specifications in the table on page 3 are defined as follows:

- Track-to-track seek time is an average of all possible single-track seeks in both directions.
- Average seek time is a true statistical random average of at least 5,000 measurements of seeks between random tracks, less overhead.
- Full-stroke seek time is one-half the time needed to seek from the first data cylinder to the maximum data cylinder and back to the first data cylinder. The full-stroke average is determined by measuring 100 full-stroke seeks in both directions.

Seek type	Typical read (msec)	Typical write (msec)
Track-to-track	6	7
Average	16	20
Full-stroke	26	28

Average latency: 8.46 msec

1.8 Spinup time

Power-on to Ready (sec)	5* typical
Standby to Ready (sec)	3 typical

* The drive will respond to selection and status commands within 2 seconds after power-up.

1.9 Reliability

Nonrecoverable read errors	1 per 10^{13} bits read
Mean time between failures	300,000 power-on hours (nominal power, at sea level, 25°C ambient temperature)
Preventive maintenance	None required
Mean time to repair	10 minutes
Service life	5 years

1.10 Environment

1.10.1 Acoustics

Drive acoustics are measured as sound pressure 1 meter from the drive.

Idle Mode (dBA, maximum)	30
Seek (dBA, maximum)	30

1.10.2 Ambient temperature

Operating	5° to 55°C (41° to 131°F)
Nonoperating	−40° to 70°C (−40° to 158°F)

1.10.3 Temperature gradient

Operating	30°C/hr (54°F/hr) max, without condensation
Nonoperating	30°C/hr (54°F/hr) max, without condensation

1.10.4 Relative humidity

Operating	8% to 80% noncondensing (10% per hour max) Max. wet bulb temperature: 29.4°C (85°F)
Nonoperating	8% to 90% noncondensing (10% per hour max) Max. wet bulb temperature: 40°C (104°F)

1.10.5 Altitude

Operating	−1,000 ft to 10,000 ft (−304 m to 3,048 m)
Nonoperating	−1,000 ft to 40,000 ft (−304 m to 12,192 m)

1.10.6 Shock

All shock specifications assume that the drive is mounted in an approved orientation with the input levels at the drive mounting screws. The nonoperating specifications assume that the read/write heads are positioned in the shipping zone.

Note. At power-down, the read/write heads automatically move to the shipping zone. The head and slider assembly park inside of the maximum data cylinder. When power is applied, the heads recalibrate to Track 0.

1.10.6.1 Operating shock

The ST9190 family drives, which incorporate SafeRite™ components, can withstand a maximum operating shock of 100 Gs without nonrecoverable data errors (based on half-sine shock pulses of 2 and 4 msec).

1.10.6.2 Nonoperating shock

The maximum nonoperating shock that the ST9190 family drives can experience without incurring physical damage or degradation in performance when subsequently put into operation is 150 Gs (based on half-sine shock pulses of 2 and 11 msec).

1.10.7 Vibration

All vibration specifications assume that the drive is mounted in an approved orientation with the input levels at the drive mounting screws. The nonoperating specifications assume that the read/write heads are positioned in the shipping zone.

1.10.7.1 Operating vibration

The following table lists the maximum vibration levels that ST9190 family drives may experience without incurring physical damage or degradation in performance.

5–22 Hz	0.020-inch displacement (double amplitude)
22–450 Hz	0.5 Gs acceleration (peak)
450–22 Hz	0.5 Gs acceleration (peak)
22–5 Hz	0.020-inch displacement (double amplitude)

1.10.7.2 Nonoperating vibration

The following table lists the maximum nonoperating vibration that ST9190 family drives may experience without incurring physical damage or degradation in performance when the drive is put into operation.

5–22 Hz	0.162-inch displacement (double amplitude)
22–450 Hz	4 Gs acceleration (peak)
450–22 Hz	4 Gs acceleration (peak)
22–5 Hz	0.162-inch displacement (double amplitude)

1.11 Power specifications

ST9190 family drives receive DC power (+5V) through pin 41 and pin 42 of the AT interface connector.

1.11.1 Power-management modes

Power management is required for low-power and portable computer systems. In most systems, you can control power management through the system setup program. The ST9190 family drives feature several power-management modes, which are described briefly below:

Active mode. The drive is in Active mode during the read/write and seek operations.

Idle mode. At power-on, the drive sets the idle timer to enter Idle mode after 5 seconds of inactivity. You can set the idle timer delay using the system setup utility. In Idle mode, the spindle remains up to speed. The heads are parked away from the data zones for maximum data safety. The buffer remains enabled, and the drive accepts all commands and returns to Active mode any time disc access is necessary.

Standby mode. The drive enters Standby mode when the host sends a Standby Immediate command. If the standby timer has been set by the host system, the drive can also enter Standby mode automatically after the drive has been inactive for a specifiable length of time. The standby timer delay is system-dependent and is usually established using the system setup utility. In Standby mode, the buffer remains enabled, the heads are parked and the spindle is at rest. The drive accepts all commands and returns to Active mode any time disc access is necessary.

Sleep mode. The drive enters Sleep mode after receiving a Sleep Immediate command from the host. The heads are parked and the spindle is at rest. The drive leaves Sleep mode when a Hard Reset or

Soft Reset command is received from the host. After receiving a soft reset, the drive exits Sleep mode and enters Standby mode with all current emulation and translation parameters intact.

Idle and standby timers. The drive sets the default time delay for the idle timer at power-on. In most systems, you can set this delay using the system setup utility. Each time the drive performs an Active function (read, write or seek), the idle and standby timers are reinitialized and begin counting down from their specified delay times to zero. If the idle timer reaches zero before any drive activity is required, the drive makes a transition to Idle mode. If the host has set the standby timer, the standby countdown continues. If the host has not set the standby timer, the drive remains in Idle mode. If the standby timer reaches zero before any drive activity is required, the drive makes a transition to Standby mode. In both Idle and Standby mode, the drive accepts all commands and returns to Active mode when disc access is necessary.

Deferred spinup. ST9190 family drives may be factory-configured for deferred spinup. If configured for deferred spinup, the drive does not spin up immediately after power-on, but waits until a command is received from the host. At power-on, the drive posts a status of 80H and all master/slave protocols are completed before the drive reports a status of 50H. After the drive receives a command from the host, it executes the normal spinup/upload process. If the host issues a soft reset prior to drive spinup, the drive responds normally, except that it does not spin up until it receives a command from the host.

1.11.2 Power consumption

Power requirements for the ST9190 family drives are listed in the table below. Typical power measurements are based on an average of drives tested under nominal conditions, using 5.0V input voltage at 25°C ambient temperature at sea level. Active mode current and power are measured with two spindle rotations between each operation and the drive in default logical geometry. Startup power is measured from the time the drive is powered on to the time the drive is ready for normal operation. Seeking power and currents are measured during one-third-stroke buffered seeks. Read/Write power and current are measured with the heads on track.

Mode	Typical watts RMS (at nominal voltage)	Typical amps RMS (at nominal voltage)
Startup	3.000	0.600
Active: Seek	1.650	0.330
Read/Write	1.600	0.320
Idle	0.700	0.140
Standby	0.155	0.031
Sleep	0.085	0.017

1.11.2.1 Typical current profile

A typical startup and current profile for an ST9190 family drive is shown in Figure 1.

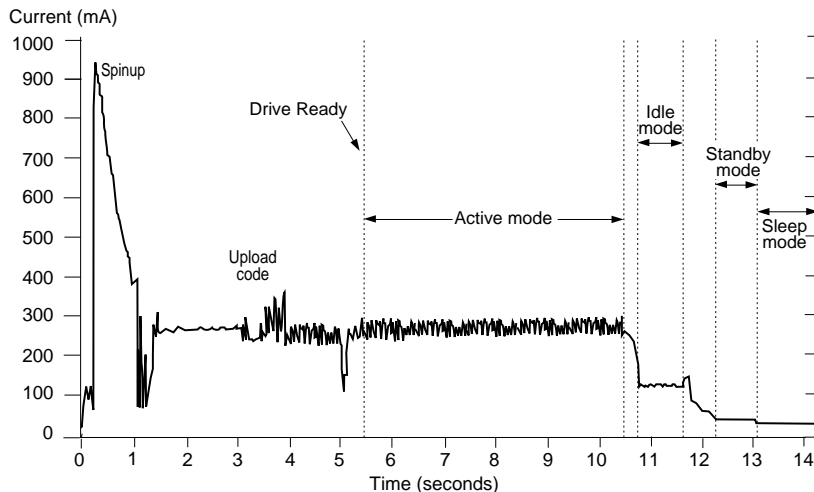

Figure 1. Typical current profile for the ST9190 family drives

1.11.3 Conducted Noise

The drive will operate with a maximum permitted conducted noise of:

- 150 mV peak-to-peak triangular wave injected noise at the power connector. The frequency is 10 Hz to 100 KHz with equivalent resistive loads.
- 100 mV peak-to-peak triangular wave injected noise at the power connector. The frequency is 100 KHz to 10 MHz with equivalent resistive loads.

Note. Equivalent resistance is calculated by dividing the respective voltage by the typical RMS read/write current.

Voltage tolerance	+5V
(including noise):	+5%, -10%

1.12 UL/CSA listing

The ST9190 family drives are listed in accordance with UL 1950 and CSA C22.2 (950-M89) and meet all applicable sections of IEC 380, IEC 435, IEC 950, VDE 0806/08.81 and EN 60950 as tested by TUV-Rheinland, North America.

1.13 FCC verification

The ST9190 family drives are intended to be contained solely within a personal computer or similar enclosure (not attached to an external device). As such, each drive is considered to be a subassembly even when it is individually marketed to the customer. As a subassembly, no Federal Communications Commission verification or certification of the device is required.

Seagate Technology, Inc. has tested this device in enclosures as described above to ensure that the total assembly (enclosure, disc drive, motherboard, power supply, etc.) does comply with the limits for a Class B computing device, pursuant to Subpart J, Part 15 of the FCC rules. Operation with noncertified assemblies is likely to result in interference to radio and television reception.

Radio and Television Interference. This equipment generates and uses radio frequency energy and if not installed and used in strict accordance with the manufacturer's instructions, may cause interference to radio and television reception.

This equipment is designed to provide reasonable protection against such interference in a residential installation. However, there is no guarantee that interference will not occur in a particular installation. If this equipment does cause interference to radio or television, which can be determined by turning the equipment on and off, you are encouraged to try one or more of the following corrective measures:

- Reorient the receiving antenna.
- Move the device to one side or the other of the radio or TV.
- Move the device farther away from the radio or TV.
- Plug the computer into a different outlet so that the receiver and computer are on different branch outlets.

If necessary you should consult your dealer or an experienced radio/television technician for additional suggestions. You may find helpful the following booklet prepared by the Federal Communications Commission: *How to Identify and Resolve Radio-Television Interference Problems*. This booklet is available from the Superintendent of Documents, U.S. Government Printing Office, Washington, DC 20402. Refer to publication number 004-000-00345-4.

2.0 Drive mounting and configuration

2.1 Handling and static-discharge precautions

After unpacking, and prior to installation, the drive may be exposed to potential handling and ESD hazards. Observe standard static-discharge precautions. A grounded wrist-strap is preferred.

Handle the drive only by the sides of the head/disc assembly. Avoid contact with the printed circuit board, all electronic components and the interface connector. Do not apply pressure to the top cover. Always rest the drive on a padded antistatic surface until you mount it in the host system.

2.2 Mounting the ST9190 family drives

You can mount ST9190 family drives in any orientation. Allow a minimum clearance of 0.030 inches (0.76 mm) around the entire perimeter of the drive for cooling.

Figure 2 on page 12 provides mounting dimensions for the ST9190 family drives. These drives conform to the industry-standard MCC direct-mounting specifications and require the use of MCC-compatible connectors in direct-mounting applications.

Note. The I/O connector pins may extend up to 0.010 inches beyond the edge of the head/disc assembly.

Caution. To avoid damaging the drive:

- Use M3X0.5 *metric* mounting screws *only*.
- Do not insert mounting screws more than 0.150 inches (3.81 mm) into the mounting holes.
- Do *not* overtighten the screws (maximum torque: 3 inch-lb).

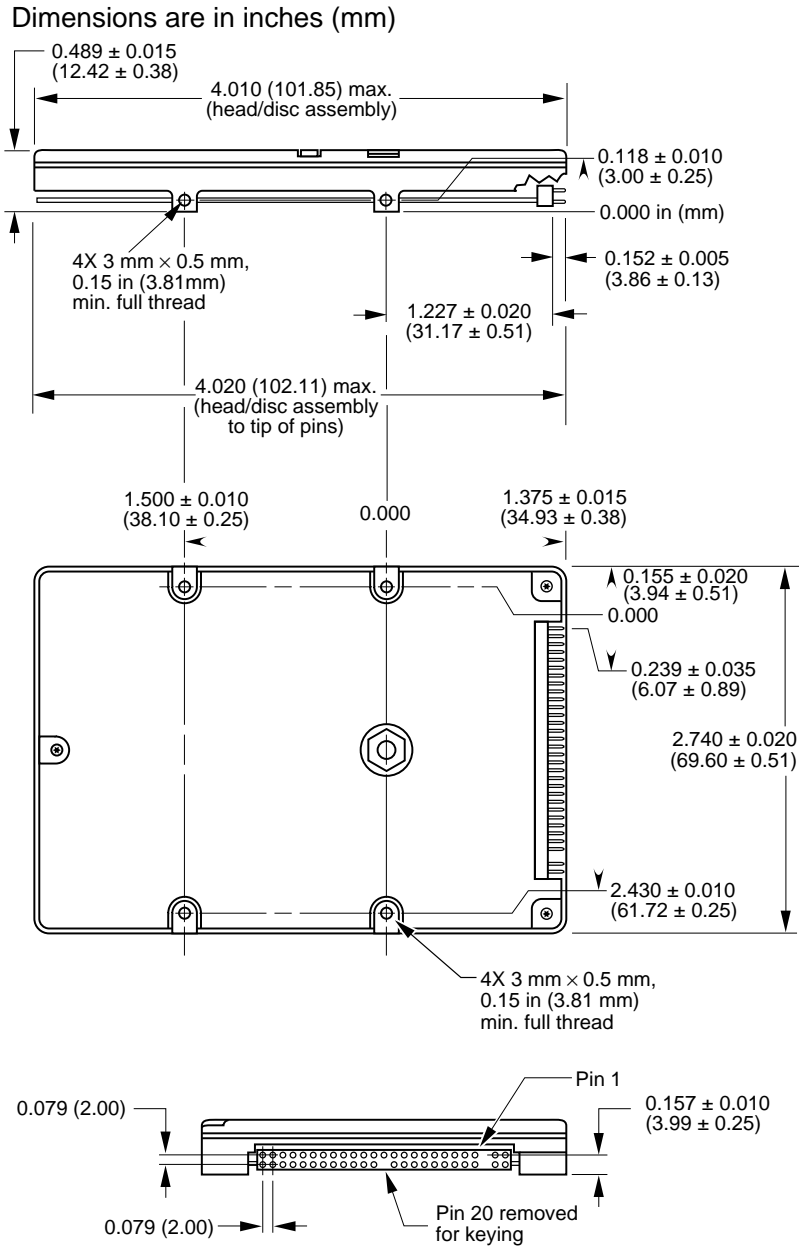

Figure 2. Mounting dimensions for the ST9190 family drives

2.3 Master/slave configuration

A master/slave relationship must be established between multiple drives attached to a single AT bus. You can configure a drive to become a master or slave by setting the master/slave jumpers as described below and shown in Figure 3 on page 14.

If only one jumper is installed or if neither jumper is installed, then the jumper settings on each drive determine whether that drive is a master or a slave.

Alternatively, you can configure an ST9190 family drive as a master or slave using the cable select option. This requires a specialized daisy-chain cable that grounds pin 28 (CSEL) on one of its two drive connectors. If you attach the drive to the grounded CSEL connector, it becomes a master. If you attach the drive to the ungrounded CSEL connector, it becomes a slave. To use this option, the host system and both drives must support cable select. To configure an ST9190 family drive for cable select, install both master/slave jumpers.

Regardless of which jumper settings are used, the slave drive must assert the DASP $\bar{}$ signal at power up and the master drive must monitor DASP $\bar{}$ at power up for the slave to be recognized.

Jumper for pins A and B	Jumper for pins C and D	Configuration
Removed	Removed	Drive is master; slave drive may be detected using DASP $\bar{}$ signal. CSEL is ignored.
Removed	Installed	Drive is master; slave drive is present. CSEL is ignored.
Installed	Removed	Drive is slave (a master drive should be present also). CSEL is ignored.
Installed	Installed	Differentiate master and slave drives using cable select. If a drive is attached to a connector in which pin 28 is grounded, it becomes a master. If a drive is attached to a connector in which pin 28 is ungrounded, it becomes a slave.

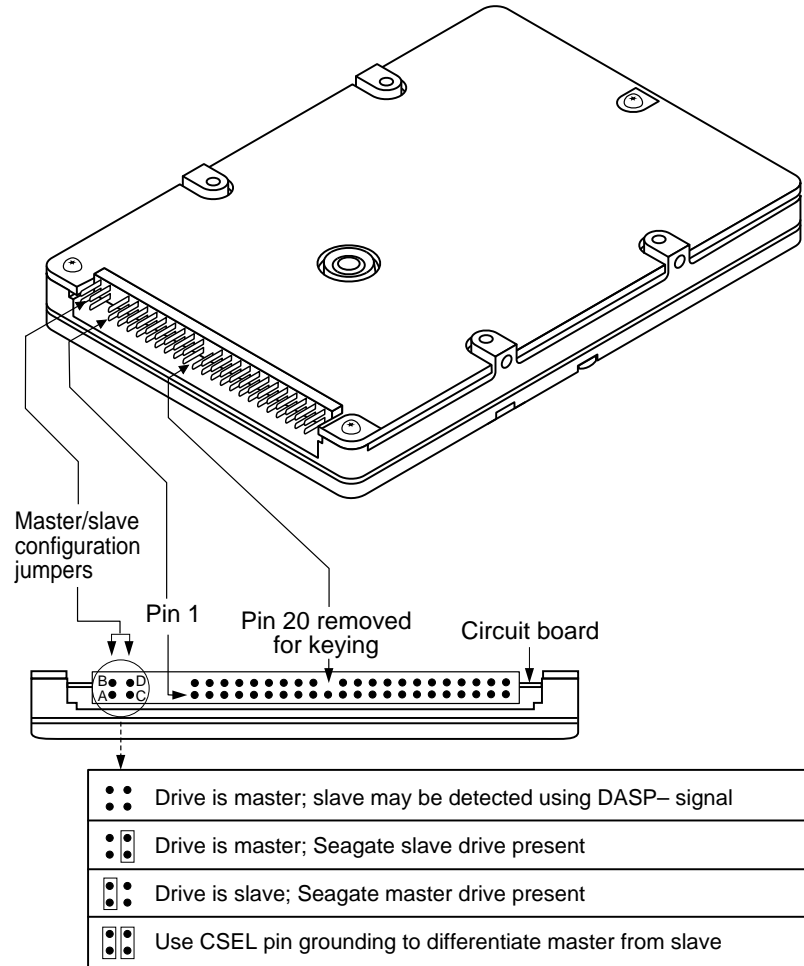

Figure 3. Connector setup for the ST9190 family drives

2.4 Remote LED

The drive indicates activity to the host through the DASP– line (pin 39) on the ATA interface. This line may be connected to a drive status indicator driving an LED at 5V. The line has a 30 mA nominal current limit.

Note. If the drive is configured to use the DASP– signal to determine master/slave configuration, this signal is shared with the LED. In this configuration, DASP– signals will be visible as LED flashes.

2.5 ECC testing

When an ST9190 family drive performs hardware-based ECC error correction on-the-fly, the drive does not report an ECC error. This allows ECC correction without degrading drive performance. Some older drive diagnostic programs test ECC features by creating small data errors and then checking to see if they are reported. Such tests, when run on an ST9190 family drive, may incorrectly report an ECC-detection failure because the drive hardware corrects the data automatically, avoiding the error rather than reporting it. Such a report does not indicate a drive malfunction.

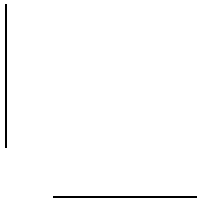
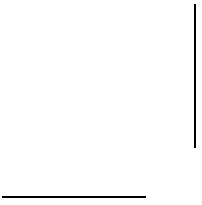

3.0 ATA interface

The ST9190 family drives use the industry-standard ATA task file interface. The drives support both 8-bit and 16-bit data transfers. They support ATA programmed input/output (PIO) modes 0 and 1, but do not support DMA data transfers.

The drives can differentiate between a hard reset and a soft reset while in Sleep mode. You can connect up to two drives on the same AT host bus. For detailed information regarding Seagate's implementation of the ATA interface, see the *Seagate ATA Interface Reference Manual*.

3.1 ATA interface connector

The drive connector is a 44-conductor connector with 2 rows of 22 male pins on 0.079-inch (2 mm) centers (see Figure 4). The mating cable connector is a 44-conductor, nonshielded connector with 2 rows of 22 female contacts on 0.079-inch (2 mm) centers. The connectors should provide strain relief and should be keyed with a plug in place of pin 20.

The ST9190 family drives are designed to support the industry standard MCC direct-mounting specifications. When installing these drives in fixed mounting applications, use only MCC-compatible connectors such as Molex part number 87368-442x. For applications involving flexible cables or printed circuit cables (PCCs), use Molex part number 87259-4413 or equivalent to connect the drive to the system. For applications that require the use of the master/slave configuration jumpers, select a connector that provides adequate clearance for the jumpers. The ATA interface cable should be no more than 18 inches long.

Dimensions are in inches (mm)

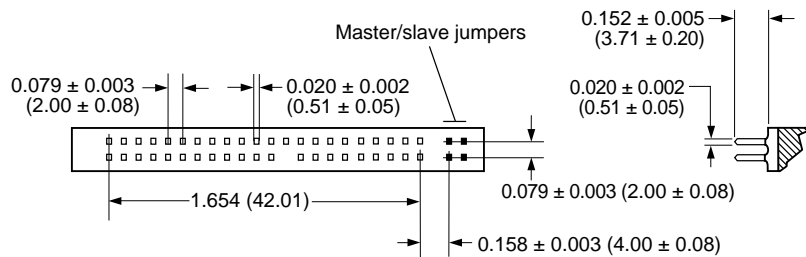

Figure 4. ATA interface connector for the ST9190 family drives

Note. The I/O connector pins may extend up to 0.010 inches beyond the edge of the head/disc assembly.

3.2 ATA interface signals and connector pins

The following diagram summarizes the signals on the ATA interface connector that are supported by the ST9190 family drives. For a detailed description of these signals, refer to the *Seagate ATA Interface Reference Manual*.

Drive pin #	Signal name	Host pin # and signal description
1	Reset-	1 Host Reset
2	Ground	2 Ground
3	DD7	3 Host Data Bus Bit 7
4	DD8	4 Host Data Bus Bit 8
5	DD6	5 Host Data Bus Bit 6
6	DD9	6 Host Data Bus Bit 9
7	DD5	7 Host Data Bus Bit 5
8	DD10	8 Host Data Bus Bit 10
9	DD4	9 Host Data Bus Bit 4
10	DD11	10 Host Data Bus Bit 11
11	DD3	11 Host Data Bus Bit 3
12	DD12	12 Host Data Bus Bit 12
13	DD2	13 Host Data Bus Bit 2
14	DD13	14 Host Data Bus Bit 13
15	DD1	15 Host Data Bus Bit 1
16	DD14	16 Host Data Bus Bit 14
17	DD0	17 Host Data Bus Bit 0
18	DD15	18 Host Data Bus Bit 15
19	Ground	19 Ground
20	(removed)	20 (No Pin)
21	Reserved	21 Reserved
22	Ground	22 Ground
23	DIOW-	23 Host I/O Write
24	Ground	24 Ground
25	DIOR-	25 Host I/O Read
26	Ground	26 Ground
27	Reserved	27 Reserved
28	CSEL	28 Cable Select
29	Reserved	29 Reserved
30	Ground	30 Ground
31	INTRQ	31 Host Interrupt Request
32	IOCS16-	32 Host 16 Bit I/O
33	DA1	33 Host Address Bus Bit 1
34	PDIAG-	34 Passed Diagnostics
35	DA0	35 Host Address Bus Bit 0
36	DA2	36 Host Address Bus Bit 2
37	CS1FX-	37 Host Chip Select 0
38	CS3FX-	38 Host Chip Select 1
39	DASP-	39 Drive Active/Slave Present
40	Ground	40 Ground
41	Power	41 +5 volts DC (logic)
42	Power	42 +5 volts DC (motor)
43	Ground	43 Ground for power pins
44	Reserved	44 Reserved

Pins 28, 34 and 39 are used for master-slave communication (details shown below).

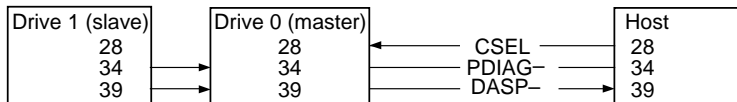

3.2.1 AT bus signal levels

Signals that the drive sends have the following output characteristics at the drive connector:

Logic low	0.0V to 0.4V
Logic high	2.5V to 5.25V

Signals that the drive receives must have the following input characteristics, measured at the drive connector:

Logic low	0.0V to 0.8V
Logic high	2.0V to 5.25V

3.3 ATA interface commands

The following table lists ATA-standard and Seagate-specific drive commands that are supported by the ST9190 family drives. For a detailed description of these commands, refer to the *Seagate ATA Interface Reference Manual*.

Command name	Command code	Supported by ST9190 family drives
ATA-standard commands		
Execute Drive Diagnostics	90H	Yes
Format Track	50H	Yes
Identify Drive	EC _H	Yes
Initialize Drive Parameters	91H	Yes
NOP	00H	No
Read Buffer	E4 _H	Yes
Read DMA (w/retry)	C8 _H	No
Read DMA (no retry)	C9 _H	No
Read Long (w/retry)	22 _H	Yes
Read Long (no retry)	23 _H	Yes
Read Multiple	C4 _H	No
Read Sectors (w/retry)	20 _H	Yes
Read Sectors (no retry)	21 _H	Yes
Read Verify Sectors (w/retry)	40 _H	Yes
Read Verify Sectors (no retry)	41 _H	Yes
Recalibrate	1 _{xH}	Yes
Seek	7 _{xH}	Yes
Set Features	EF _H	Yes
Set Multiple Mode	C6 _H	No
Write Buffer	E8 _H	Yes
Write DMA (w/retry)	CA _H	No

Command name	Command code	Supported by ST9190 family drives
Write DMA (no retry)	CB _H	No
Write Long (w/retry)	32 _H	Yes
Write Long (no retry)	33 _H	Yes
Write Multiple	C5 _H	No
Write Same	E9 _H	No
Write Sectors (w/retry)	30 _H	Yes
Write Sectors (no retry)	31 _H	Yes
Write Verify	3C _H	No
ATA-standard power management commands		
Check Power Mode	98 _H or E5 _H	Yes
Idle	97 _H or E3 _H	Yes
Idle Immediate	95 _H or E1 _H	Yes
Sleep	99 _H or E6 _H	Yes
Standby	96 _H or E2 _H	Yes
Standby Immediate	94 _H or E0 _H	Yes
Seagate-specific power management commands		
Active and Set Idle Timer	FB _H	Yes
Active Immediate	F9 _H	Yes
Check Idle Mode	FD _H	Yes
Idle Immediate	F8 _H	Yes
Idle and Set Idle Timer	FA _H	Yes

The following commands are specific to the ST9190 family drives or contain drive-specific features.

3.3.1 Identify Drive command

The Identify Drive command (command code EC_H) transfers information about the drive to the host after power up. The data is organized as a single 512-byte block of data, whose contents are shown in the table below. All reserved bits or words should be set to zero. Parameters listed with an “x” are drive specific or vary with the state of the drive. See Section 1 of this manual for default parameter settings for the ST9190 family drives.

Word	Description	ST9190AG	ST9140AG
0	Configuration information: Bit 10: disc transfer > 10 Mbits/sec Bit 6: fixed drive Bit 4: head switch time > 15 μsec Bit 3: not MFM encoded Bit 1: hard sectored disc	045A _H	045A _H
1	Number of fixed cylinders (default logical emulation)	0369 _H	03D4 _H
2	ATA reserved	0000 _H	0000 _H
3	Number of heads (default)	0010 _H	000F _H
4	Number of unformatted bytes per track	8D90 _H	8D90 _H
5	Number of unformatted bytes per sector	0248 _H	0248 _H
6	Number of sectors per track (default logical emulation)	0018 _H	0011 _H
7–9	ATA reserved	0000 _H	0000 _H
10–19	Serial Number: (20 ASCII characters, 0000 _H = none)	ASCII	ASCII
20	Controller type = dual-ported multisector buffer with caching	0003 _H	0003 _H
21	Buffer size (number of 512-byte sectors)	00F0 _H	00F0 _H

Word	Description	ST9190AG	ST9140AG
22	Number of ECC bytes available (16)	0010H	0010H
23–26	Firmware revision (8 ASCII character string): <i>xx</i> = ROM version, <i>ss.tt</i> = RAM version	<i>xx.ss.tt</i>	<i>xx.ss.tt</i>
27–46	Drive model number: (40 ASCII characters, padded to end of string)	ST9190AG	ST9140AG
47	Maximum sectors per interrupt on read/write multiple	0000H	0000H
48	Double word I/O (not supported)	0000H	0000H
49	DMA data transfer and IORDY (supported)	0000H	0000H
50	ATA reserved	0000H	0000H
51	PIO data transfer cycle timing mode	0000H	0000H
52	DMA transfer cycle timing mode	0000H	0000H
53	Validity of words 54–58 and words 64–70 (1 indicates words 54–58 may be valid)	0001H	0001H
54	Number of cylinders (current emulation mode)	<i>xxxxH</i>	<i>xxxxH</i>
55	Number of heads (current emulation mode)	<i>xxxxH</i>	<i>xxxxH</i>
56	Number of sectors per track (current emulation mode)	<i>xxxxH</i>	<i>xxxxH</i>
57–58	Number of sectors (current emulation mode)	<i>xxxxH</i>	<i>xxxxH</i>
59	Read Multiple/Write Multiple setting (not supported).	0000H	0000H
60–61	ATA reserved	0000H	0000H
62	Single-word DMA settings (DMA not supported)	0000H	0000H

continued

continued from previous page

Word	Description	ST9190AG	ST9140AG
63	Multiword DMA settings (DMA not supported)	0000 _H	0000 _H
64	Advanced PIO mode settings (not supported)	0000 _H	0000 _H
65	Minimum multiword DMA transfer cycle time per word (not supported)	0000 _H	0000 _H
66	Recommended multiword DMA transfer cycle time per word (not supported)	0000 _H	0000 _H
67	Minimum PIO cycle time without IORDY flow control (not supported)	0000 _H	0000 _H
68	Minimum PIO cycle time with IORDY flow control (not supported)	0000 _H	0000 _H
69-127	ATA reserved	0000 _H	0000 _H
128-159	Seagate reserved	xxxx _H	xxxx _H
160-255	ATA reserved	0000 _H	0000 _H

3.3.2 Set Features command

This command controls the implementation of various features supported by the drive. When the drive receives this command, it sets BSY, checks the contents of the Features register, clears BSY and generates an interrupt. If the value in the register does not represent a feature supported by the drive, the command is aborted. Power-on default has the read look-ahead and write caching features enabled and 4 bytes of ECC. The acceptable values for the Features register are defined as follows:

- 02_H Enable write cache (*default*)
- 44_H 16 bytes of ECC apply on read long and write long commands
- 55_H Disable read look-ahead (read cache) feature
- 66_H Disable reverting to power-on defaults
- 82_H Disable write cache
- AA_H Enable read look-ahead (read cache) feature (*default*)
- BB_H 4 bytes of ECC apply on read long and write long commands (*default*)
- CC_H Enable reverting to power-on defaults (*default*)

At power-on, or after a hardware reset, the default values of the features are as indicated above. A software reset also changes the features to default values unless a 66_H command has been received.

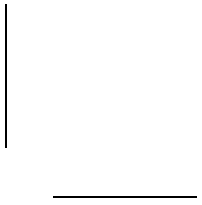
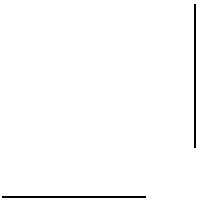

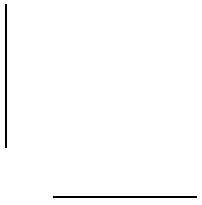
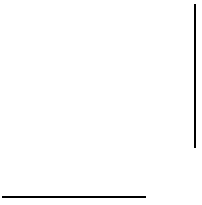



Seagate Technology, Inc.
920 Disc Drive, Scotts Valley, California 95066, USA

Publication Number: 36230-001, Rev. B, Printed in USA