



.....
Medalist 17242, Medalist 13032
.....

Medalist 10232, Medalist 8422
.....

Medalist 4312
.....

Ultra ATA Interface Drives
.....

Product Manual
.....

.....
Medalist 17242, Medalist 13032
.....

Medalist 10232, Medalist 8422
.....

Medalist 4312
.....

Ultra ATA Interface Drives
.....

Product Manual
.....



© 1999 Seagate Technology, Inc. All rights reserved

Publication Number: 20400143-001, Rev. A, March 1999

Seagate, Seagate Technology, the Seagate logo, Medalist and the Medalist logo are registered trademarks of Seagate Technology, Inc. Other product names are registered trademarks or trademarks of their owners.

Seagate reserves the right to change, without notice, product offerings or specifications. No part of this publication may be reproduced in any form without written permission from Seagate Technology, Inc.

Contents

1.0 Drive specifications	5
1.1 Formatted capacity	5
1.1.1 Default logical geometry	5
1.1.2 Supported CHS translation geometries	6
1.2 Physical organization	6
1.3 Recording and interface technology	6
1.4 Physical characteristics	7
1.5 Seek time	7
1.6 Start/stop times	8
1.7 Power specifications	8
1.7.1 Power consumption	8
1.7.2 Conducted noise	10
1.7.3 Voltage tolerance	10
1.7.4 Power-management modes	10
1.8 Environmental tolerances	11
1.8.1 Ambient temperature	11
1.8.2 Temperature gradient	11
1.8.3 Humidity	11
1.8.4 Altitude	12
1.8.5 Shock	12
1.8.6 Vibration	12
1.9 Drive acoustics	13
1.10 Electromagnetic susceptibility	13
1.11 Reliability	14
1.12 Agency certification	14
1.12.1 Safety certification	14
1.12.2 Electromagnetic Compatibility	14
1.12.3 FCC verification	15
2.0 Drive mounting and configuration	17

2.1 Handling and static-discharge precautions	17
2.2 Jumper settings	17
2.2.1 Master/slave configuration	17
2.2.2 Alternate capacity jumper	18
2.3 Ultra ATA/66 cable	18
2.4 Drive mounting	19
3.0 ATA interface	22
3.1 ATA interface signals and connector pins	22
3.2 ATA Interface commands	24
3.2.1 Supported ATA commands	24
3.2.2 Identify Drive command	26
3.2.3 Set Features command	30
3.2.4 S.M.A.R.T. commands	31

Figures

Figure 1. Typical startup and operation current profile	9
Figure 2. Alternate capacity jumper and master/slave jumper	19
Figure 3. Mounting dimensions—top, side and end view	20
Figure 4. I/O pins and supported ATA signals.	23

Introduction

This manual describes the functional, mechanical and interface specifications for the Medalist® 17242 (ST317242A), Medalist 13032 (ST313032A), Medalist 10232 (ST310232A), Medalist 8422 (ST38422A) and the Medalist 4312 (ST34312A). These drives are referred to throughout this manual by their model numbers. These drives provide the following key features:

- Low power consumption
- Quiet operation
- Support for S.M.A.R.T. drive monitoring and reporting
- High instantaneous (burst) data-transfer rates (up to 66.6 Mbytes per second) using Ultra DMA mode 4
- Full-track multiple-sector transfer capability without local processor intervention
- 512-Kbyte cache
- State-of-the-art cache and on-the-fly error-correction algorithms
- Support for Read Multiple and Write Multiple commands
- Support for autodetection of master/slave drives that use cable select (CSEL)
- These drives use MR recording heads and EPRML technology, which provide the drives with increased areal density.

Specification summary table

The specifications listed in this table are for quick reference. For details on specification measurement or definition, see the appropriate section of this manual.

Drive Specification	ST317242A	ST313032A	ST310232A	ST38422A	ST34312A
Guaranteed Mbytes ($\times 10^6$ bytes)	17,245	13,022	10,242	8,622	4,311
Guaranteed sectors	33,683,328	25,434,228	20,005,650	16,841,664	8,420,832
Bytes per sector	512				
Default sectors per track	63				
Default read/write heads	16				
Default cylinders	16,383	16,383	16,383	16,383	8,354
Physical read/write heads	8	6	6	4	2
Discs	4	3	3	2	1
Recording density (bits/inch max)	239,000				
Track density (tracks/inch)	13,405				
Areal density (Mbits/inch ²)	3,200				
Spindle speed (RPM)	5,400				
Internal data-transfer rate (Mbits/sec max)	188				
I/O data-transfer rate (Mbytes/sec max)	66.6				
ATA data-transfer modes supported	PIO modes 0, 1, 2, 3, 4; Multiword DMA modes 0, 1, 2; Ultra DMA modes 0, 1, 2, 3, 4				
Cache buffer (Kbytes)	512				
Height (mm max)	26.10				
Width (mm max)	101.85				

Drive Specification	ST317242A	ST313032A	ST310232A	ST38422A	ST34312A
Length (mm max)	147.00				
Weight (grams typical)	558				
Track-to-track seek time (msec typical)	1.3 (read), 2.1 (write)				
Average seek time (msec typical)	9.0 (read), 10.5 (write)				
Full-stroke seek time (msec typical)	18 (read), 20 (write)				
Average latency (msec)	5.6				
Power-on to ready (sec typical)	12				
Standby to ready (sec typical)	12				
Startup current: 12V (peak) 5V (RMS)	2.2 amps 0.6 amps				
Seek power and current (mean)	8.5 watts				
Read/Write power and current (typical)	5.5 watts				
Idle mode power and current (typical)	5.5 watts				
Standby mode power and current (typical)	1.1 watts				
Sleep mode power and current (typical)	1.1 watts				
Voltage tolerance (including noise)	5V \pm 5% 12V \pm 10%				
Ambient temperature	0° to 55°C (op.), -40° to 70°C (nonop.)				
Temperature gradient (per hour max)	20°C				
Relative humidity (op. and nonop.)	8% to 80% (op.) 5% to 95% (nonop.)				

Drive Specification	ST317242A	ST313032A	ST310232A	ST38422A	ST34312A
Relative humidity gradient	10% per hour max				
Wet bulb temperature (max)	29.4°C (op.), 29.4°C (nonop.)				
Altitude (meters below mean sea level, max)	-122 to 3,048 (op.) -122 to 12,192 (nonop.)				
Shock, operating (Gs max at 2 msec)	63				
Shock, nonoperating (Gs max at 2 msec)	300				
Vibration, operating	0.50 G (0 to peak, 22–350 Hz)				
Vibration, nonoperating	5.0 Gs (0 to peak, 22–350 Hz)				
Drive acoustics (bels—sound power) Idle mode (dBA—sound pressure)	3.3 (typical), 3.8 (max) 30 (typical)				
Drive acoustics (bels—sound power) Read/Write mode (dBA—sound pressure)	3.7 (typical), 4.1 (max) 32 (typical)				
Nonrecoverable read errors	1 per 10 ¹⁴ bits read				
Mean time between failures (power-on hours)	400,000				
Contact start-stop cycles (25°C, 40% relative humidity)	40,000				
Service life (years)	5				

1.0 Drive specifications

Unless otherwise noted, all specifications are measured under ambient conditions, at 25°C, and nominal power. For convenience, the phrases *the drive* and *this drive* are used throughout this manual to indicate the ST317242A, ST313032A, ST310232A, ST38422A and the ST34312A.

1.1 Formatted capacity

Drive Model	Guaranteed Mbytes (1 Mbyte = 10 ⁶ bytes)	Guaranteed sectors	Bytes per sector
ST317242A	17,245	33,683,328	512
ST313032A	13,022	25,434,228	512
ST310232A	10,242	20,005,650	512
ST38422A	8,622	16,841,664	512
ST34312A	4,311	8,420,832	512

Note. DOS systems cannot access more than 528 Mbytes on a drive unless 1) the host system supports and is configured for LBA addressing or for extended CHS addressing, 2) the host system contains a specialized drive controller, or 3) the host system runs BIOS translation software. Contact your Seagate® representative for details.

1.1.1 Default logical geometry

CHS Mode	Cylinders	Read/Write heads	Sectors per track
ST317242A	16,383	16	63
ST313032A	16,383	16	63
ST310232A	16,383	16	63
ST38422A	16,383	16	63
ST34312A	8,354	16	63

LBA Mode

When addressing either drive in LBA mode, all blocks (sectors) are consecutively numbered from 0 to $n-1$, where n is the number of guaranteed sectors as defined above.

1.1.2 Supported CHS translation geometries

These drives support any translation geometry that satisfies *all* of the following conditions:

- Sectors per track ≤ 63
- Cylinders $\leq 16,383$ (for drives over 8.4 Gbytes)
- Read/Write heads ≤ 16

Note. The CHS addressing supports capacities up to 8.4 Gbytes. To see the full capacity of drives greater than 8.4 Gbytes, use the LBA addressing mode.

The ST317242A logical cylinders are:

Logical cylinders=33,683,328/(logical sectors per track \times logical heads)

The ST313032A logical cylinders are:

Logical cylinders=25,434,228/(logical sectors per track \times logical heads)

The ST310232A logical cylinders are:

Logical cylinders=20,005,650/(logical sectors per track \times logical heads)

The ST38422A logical cylinders are:

Logical cylinders=16,841,664/(logical sectors per track \times logical heads)

The ST34312A logical cylinders are:

Logical cylinders=8,420,832/(logical sectors per track \times logical heads)

1.2 Physical organization

Drive Model	Read/Write heads (MR)	Number of discs
ST317242A	8	4
ST313032A	6	3
ST310232A	6	3
ST38422A	4	2
ST34312A	2	1

1.3 Recording and interface technology

Interface	ATA
Recording method	EPRML (16,17)
Recording density (bits/inch)	239,000
Track density (tracks/inch)	13,405

Areal density (Mbits/inch ²)	3,200
Spindle speed (RPM) (± 0.2%)	5,400
Internal data-transfer rate (Mbits per second max)	188
I/O data-transfer rate (Mbytes per second max)	16.6 (PIO mode 4 with IORDY) 16.6 (multiword DMA mode 2) 66.6 (Ultra DMA mode 4)
Interleave	1:1
Cache buffer (Kbytes)	512

1.4 Physical characteristics

Drive Specification	ST317242A, ST313032A, ST310232A, ST38422A, ST34312A
Maximum height (mm) (inches)	26.10 1.028
Maximum width (mm) (inches)	101.85 4.010
Maximum length (mm) (inches)	147.00 5.787
Typical weight (grams) (pounds)	558 1.2

1.5 Seek time

The measurements are taken with nominal power at 25°C ambient temperature. All times are measured using drive diagnostics. The specifications in the table below are defined as follows:

- Track-to-track seek time is an average of all possible single-track seeks in both directions.
- Average seek time is a true statistical random average of at least 5,000 measurements of seeks between random tracks, less overhead.
- Full-stroke seek time is one-half the time needed to seek from the first data cylinder to the maximum data cylinder and back to the first data cylinder. The full-stroke typical value is determined by averaging 100 full-stroke seeks in both directions.

Seek type	Read (msec, typ.)	Write (msec, typ.)
Track-to-track	1.3	2.1
Average	9.0	10.5
Full-stroke	18	20
Average latency: 5.6 msec		

Note. These drives are designed to consistently meet the seek times represented in this manual. Physical seeks, regardless of mode (such as track-to-track and average) are expected to meet or exceed the noted values. Due to the manner in which these drives are formatted, however, benchmark tests that include command overhead or that measure logical seeks may produce results that vary from these specifications.

1.6 Start/stop times

Power-on to Ready (sec)	12 (typical)
Standby to Ready (sec)	12 (typical)
Ready to spindle stop (sec)	12 (typical)

1.7 Power specifications

The drive receives DC power (+5V or +12V) through a four-pin standard drive power connector.

1.7.1 Power consumption

Power requirements for the drives are listed in the table on page 9. Typical power measurements are based on an average of drives tested, under nominal conditions, using 5.0V input voltage at 25°C ambient temperature.

Spinup power is measured from the time of power-on to the time that the drive spindle reaches operating speed.

During Seek mode, the read/write actuator arm moves toward a specific position on the disc surface and does not execute a read or write operation. Servo electronics are active. Seek mode power represents the worst-case power consumption, using only random seeks with read or write latency time. This mode is not typical and is provided for worst-case information.

Read/Write power and current are measured with the heads on track, based on a 16-sector write followed by a 32-msec delay, then a 16-sector read followed by a 32-msec delay.

Operating power and current are measured using 40 percent random seeks, 40 percent read/write mode (1 write for each 10 reads), and 20 percent drive inactive.

Idle mode power is measured with the drive up to speed, with servo electronics active, and with the heads in a random track location.

During Standby mode, the drive accepts commands, but the drive is not spinning, and servo and read/write electronics are in power-down mode.

Mode	Typical Watts RMS	Typical Amps RMS	
		5V	12V
Spinup	—	0.6 (Peak)	2.2 (Peak)
Seek (Random, no read/write)	8.5	0.5	0.5
Read/Write	5.5	0.5	0.25
Operating	7.3	0.5	0.4
Idle	5.5	0.5	0.25
Standby	1.08	0.2	0.007
Sleep	1.08	0.2	0.007

1.7.1.1 Typical current profile

Figure 1 shows a typical current profile.

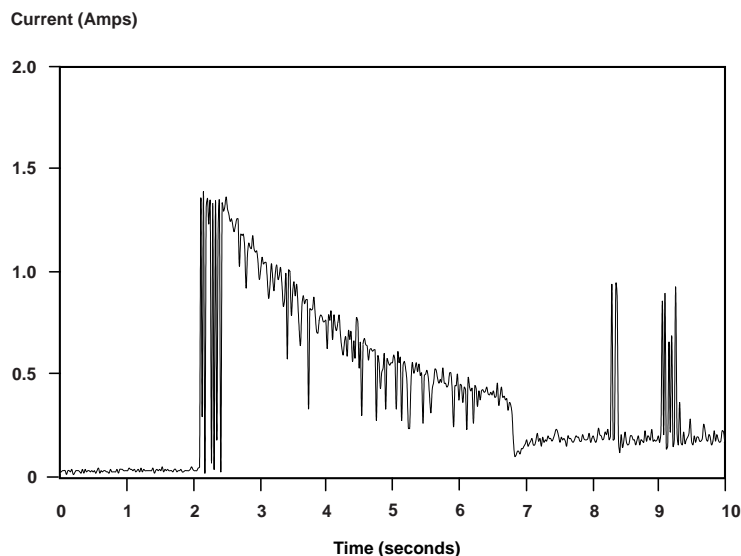

Figure 1. Typical startup and operation current profile

1.7.2 Conducted noise

Input noise ripple is measured at the host system power supply across an equivalent 80-ohm resistive load on the +12 volt line or an equivalent 15-ohm resistive load on the +5 volt line.

- Using 12-volt power, the drive is expected to operate with a maximum of 120 mV peak-to-peak square-wave injected noise at up to 10 MHz.
- Using 5-volt power, the drive is expected to operate with a maximum of 100 mV peak-to-peak square-wave injected noise at up to 10 MHz.

Note. Equivalent resistance is calculated by dividing the nominal voltage by the typical RMS read/write current.

1.7.3 Voltage tolerance

Voltage tolerance (including noise): 5V \pm 5% and 12V \pm 10%

1.7.4 Power-management modes

These drives provide programmable power management to provide greater energy efficiency. In most systems, you can control power management through the system setup program. These Seagate drives feature several power-management modes, which are summarized in the following table and described in more detail below:

Mode	Heads	Spindle	Buffer
Active	Tracking	Rotating	Enabled
Idle	Tracking	Rotating	Enabled
Standby	Parked	Stopped	Enabled
Sleep	Parked	Stopped	Disabled

Active mode. The drive is in Active mode during the read/write and seek operations.

Idle mode. The buffer remains enabled, and the drive accepts all commands and returns to Active mode any time disc access is necessary.

Standby mode. The drive enters Standby mode when the host sends a Standby Immediate command. If the host has set the standby timer, the drive can also enter Standby mode automatically after the drive has been inactive for a specifiable length of time. The standby timer delay is established using a Standby or Idle command. In Standby mode, the heads are parked and the spindle is at rest. The drive accepts all commands and returns to Active mode any time disc access is necessary.

Sleep mode. The drive enters Sleep mode after receiving a Sleep command from the host. The heads are parked and the spindle is at rest. The drive leaves Sleep mode after it receives a Hard Reset or Soft Reset from the host. After receiving a reset, the drive exits Sleep mode and enters Active mode with all current translation parameters intact.

Idle and Standby timers. Each time the drive performs an Active function (read, write or seek), the standby timer is reinitialized and begins counting down from its specified delay times to zero. If the standby timer reaches zero before any drive activity is required, the drive makes a transition to Standby mode. In both Idle and Standby mode, the drive accepts all commands and returns to Active mode when disc access is necessary.

1.8 Environmental tolerances

1.8.1 Ambient temperature

Operating	0° to 55°C (32° to 131°F)
Nonoperating	−40° to 70°C (−40° to 158°F)

Note. Above 1,000 feet (305 meters), the maximum temperature is derated linearly to 112°F (44°C) at 10,000 feet (3,048 meters). Operating ambient temperature is defined as the temperature of the environment immediately surrounding the drive.

1.8.2 Temperature gradient

Operating	20°C/hour (36°F/hour) max, without condensation
Nonoperating	20°C/hour (36°F/hour) max, without condensation

1.8.3 Humidity

1.8.3.1 Relative Humidity

Operating	8% to 80% noncondensing (10% per hour max)
Nonoperating	5% to 95% noncondensing (10% per hour max)

1.8.3.2 Wet bulb temperature

Operating	29.4°C (84°F) max
Nonoperating	29.4°C (84°F) max

1.8.4 Altitude

Operating	-122 m to 3,048 m (-400 ft to 10,000+ ft)
Nonoperating	-122 m to 12,192 m (-400 ft to 40,000+ ft)

1.8.5 Shock

During shock tests, the drive was mounted securely with the input shock applied at the drive mounting screws. Shock may be applied in the X, Y or Z axis.

1.8.5.1 Operating shock

These drives comply with the performance levels specified in this document when subjected to a maximum operating shock of 63 Gs (based on half-sine shock pulses of 2 msec). Shocks are not to be repeated more than two times per second.

1.8.5.2 Nonoperating shock

The nonoperating shock level that the drive can experience without incurring physical damage or degradation in performance when subsequently put into operation is 300 Gs (based on a nonrepetitive half-sine shock pulse of 2 msec duration). Shock pulses are defined by MIL-STD-202F.

1.8.6 Vibration

During vibration tests, the drive was mounted securely with the input vibration applied at the drive mounting screws. Vibration may be applied in the X, Y or Z axis.

1.8.6.1 Operating vibration

The following table lists the maximum vibration levels that the drive may experience while meeting the performance standards specified in this document.

5–22 Hz	0.020-inch displacement (peak to peak)
22–350 Hz	0.50 Gs acceleration (zero to peak)

1.8.6.2 Nonoperating vibration

The following table lists the maximum nonoperating vibration that the drive may experience without incurring physical damage or degradation in performance when subsequently put into operation.

5–22 Hz	0.20-inch displacement (peak to peak)
22–350 Hz	5.0 Gs acceleration (zero to peak)

1.9 Drive acoustics

Drive acoustics were measured as overall A-weighted acoustic sound power levels (no pure tones). All measurements are generally consistent with ISO document 7779. Sound power measurements were taken under essentially free-field conditions over a reflecting plane. For all tests, the drive was oriented with the cover facing upward.

For the Seek mode, the drive was placed in seek only. Currently for these drives, the approximate number of seeks per second is 26.6. The number of seeks per second is defined by the following equation:

$$\text{Number of seeks per second} = 0.4 / (\text{average latency} + \text{average access time}).$$

Mode	Typical sound power (bels)	Maximum sound power (bels)
Idle	3.3	3.8
Read/Write	3.7	4.1

1.10 Electromagnetic susceptibility

The drive operates without errors when subjected to the following:

Radiated noise	≤ 3 volt/meter, 30 Hz to 500 MHz
Electrostatic discharge*	≤ 10 KVolts
Magnetic field strength	≤ 5 Gauss

* Electrostatic discharge susceptibility is measured with the drive mounted in a representative computer system (mounted to a ground plane with earth grounding). Discharges are applied to the bezel or other external surfaces on the ground plane.

1.11 Reliability

Nonrecoverable read errors	1 per 10 ¹⁴ bits read, max
Mean time between failures	400,000 power-on hours (nominal power, 25°C ambient temperature)
Contact start-stop cycles	40,000 cycles (at nominal voltage and temperature, with 60 cycles per hour and a 50% duty cycle)
Preventive maintenance	None required

1.12 Agency certification

1.12.1 Safety certification

The drives are recognized in accordance with UL 1950 and CSA C22.2 (950) and meet all applicable sections of IEC950 and EN 60950 as tested by TUV North America.

1.12.2 Electromagnetic Compatibility

Hard drives that display the CE marking comply with European Union requirements specified in Electromagnetic Compatibility Directives. Testing is performed to standards EN50082-1 and EN55022-B.

Seagate uses an independent laboratory to confirm compliance with the EC directives specified in the previous paragraph. Drives are tested in representative end-user systems. Although CE-marked Seagate drives comply with the directives when used in the test systems, we cannot guarantee that all systems will comply with the directives. The drive is designed for operation inside a properly designed enclosure, with properly shielded I/O cable (if necessary) and terminators on all unused I/O ports. Computer manufacturers and system integrators should confirm EMC compliance and provide CE marking for their products.

Australian C-Tick

If these models have the C-Tick marking, they comply with the Australia/New Zealand Standard AS/NZS3548 1995 and meet the Electromagnetic Compatibility (EMC) Framework requirements of Australia's Spectrum Management Agency (SMA).

1.12.3 FCC verification

These drives are intended to be contained solely within a personal computer or similar enclosure (not attached as an external device). As such, each drive is considered to be a subassembly even when it is individually marketed to the customer. As a subassembly, no Federal Communications Commission verification or certification of the device is required.

Seagate Technology, Inc. has tested this device in enclosures as described above to ensure that the total assembly (enclosure, disc drive, motherboard, power supply, etc.) does comply with the limits for a Class B computing device, pursuant to Subpart J, Part 15 of the FCC rules. Operation with noncertified assemblies is likely to result in interference to radio and television reception.

Radio and Television Interference. This equipment generates and uses radio frequency energy and if not installed and used in strict accordance with the manufacturer's instructions, may cause interference to radio and television reception.

This equipment is designed to provide reasonable protection against such interference in a residential installation. However, there is no guarantee that interference will not occur in a particular installation. If this equipment does cause interference to radio or television, which can be determined by turning the equipment on and off, you are encouraged to try one or more of the following corrective measures:

- Reorient the receiving antenna.
- Move the device to one side or the other of the radio or TV.
- Move the device farther away from the radio or TV.
- Plug the computer into a different outlet so that the receiver and computer are on different branch outlets.

If necessary, you should consult your dealer or an experienced radio/television technician for additional suggestions. You may find helpful the following booklet prepared by the Federal Communications Commission: *How to Identify and Resolve Radio-Television Interference Problems*. This booklet is available from the Superintendent of Documents, U.S. Government Printing Office, Washington, DC 20402. Refer to publication number 004-000-00345-4.

2.0 Drive mounting and configuration

2.1 Handling and static-discharge precautions

After unpacking, and before installation, the drive may be exposed to potential handling and electrostatic discharge (ESD) hazards. Observe the following standard handling and static-discharge precautions:

Caution:

- Keep the drive in its static-shielded bag until you are ready to complete the installation. Do not attach any cables to the drive while it is in its static-shielded bag.
- Before handling the drive, put on a grounded wrist strap, or ground yourself frequently by touching the metal chassis of a computer that is plugged into a grounded outlet. Wear a grounded wrist strap throughout the entire installation procedure.
- Handle the drive by its edges or frame *only*.
- The drive is extremely fragile—handle it with care. Do not press down on the drive top cover.
- Always rest the drive on a padded, antistatic surface until you mount it in the computer.
- Do not touch the connector pins or the printed circuit board.
- Do not remove the factory-installed labels from the drive or cover them with additional labels. Removal voids the warranty. Some factory-installed labels contain information needed to service the drive. Other labels are used to seal out dirt and contamination.

2.2 Jumper settings

2.2.1 Master/slave configuration

You must establish a master/slave relationship between two drives that are attached to a single AT bus. You can configure a drive as a master or slave by setting the master/slave jumpers, shown in Figure 2 on page 19.

These drives support master/slave configuration using the cable select option. This requires a special daisy-chain cable that grounds pin 28 (CSEL) on one of its two drive connectors. If you attach the drive to the grounded CSEL connector, it is a master. If you attach the drive to the ungrounded CSEL connector, it is a slave. To use this option, the host system and both drives must support cable select, and both drives must

be configured for cable select. To configure this drive for cable select, install a jumper as shown in Figure 2.

For the master drive to recognize the slave drive using the DASP– signal, the slave drive must assert the DASP– signal at power up, and the master drive must monitor DASP– at power up.

2.2.2 Alternate capacity jumper

Some older computers may “hang” if their BIOS detects a hard drive that has more than 4,092 cylinders at startup. To allow these computers to recognize the ST317242A, ST313032A, ST310232A, ST38422A or the ST34312A, these drives include a capacity-limiting jumper, which sets the drive’s default translation geometry to 4,092 cylinders. This limits the drive’s capacity to 2.1 Gbytes, unless third-party software is used.

2.3 Ultra ATA/66 cable

An 80-conductor 40-pin cable is required to run Ultra DMA mode 3 and 4. This cable uses even-numbered conductors connected to the ground pins to improve signal integrity.

Note. The drive supports both host and drive cable detection. The host detects the 80-conductor cable by sampling pin 34, CBLID—, on the interface bus. The drive detects the 80-conductor cable by sensing a capacitor at the host side through the CBLID— signal. The result is reported in a Fast Rise Detected bit (bit 13 of word 93 in the Identify drive parameter block).

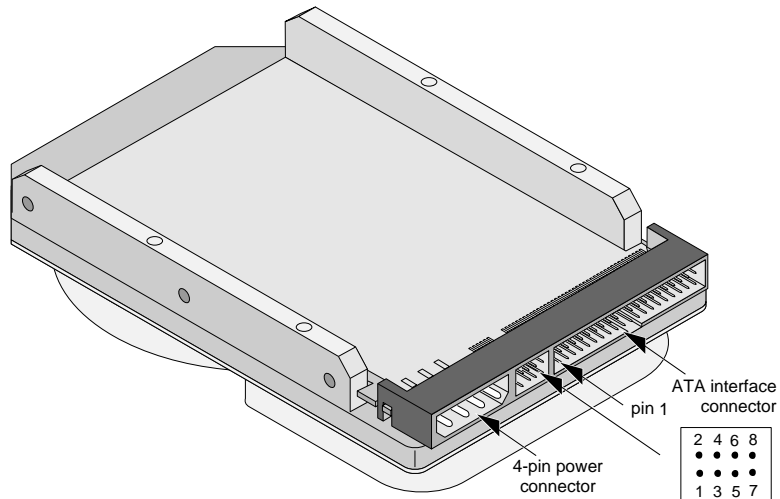

Alternate capacity and master/slave jumper settings

1. The drive is shipped with a jumper on pins 7 and 8. This configures the drive for master or single drive operation.
2. Consult your computer manual to determine whether your computer supports cable select.
3. Use this jumper setting *only* if the drive does not work with a jumper on pins 7 and 8.
4. Use this jumper setting if your computer fails to boot because it cannot recognize drives with more than 4,092 cylinders.

Slave	••••
Master or single drive ¹	•••••
Enable cable select ²	•••••
Master with non-ATA compatible slave ³	•••••
Limit capacity to 2.1 Gbytes (4,092 cylinders) ⁴	•••••

Figure 2. Alternate capacity jumper and master/slave jumper

2.4 Drive mounting

You can mount the drive in any orientation using four screws in the side-mounting holes or four screws in the bottom-mounting holes. See Figure 3 on page 20 for drive mounting dimensions.

Important mounting precautions:

- Allow a minimum clearance of 0.030 inches (0.76 mm) around the entire perimeter of the drive for cooling.
- Use only 6-32 UNC mounting screws.
- The screws should be inserted no more than 0.22 inch (5.58 mm) into the bottom mounting holes and no more than 0.20 inch (5.0 mm) into the side mounting holes.
- Do not overtighten the mounting screws (maximum torque: 3 inch-lb, 0.34 N.m, 3.45 kgf.cm).
- Do not use a drive interface cable that is more than 18 inches (457 mm) long.

Note. Dimensions are shown in mm (inches)

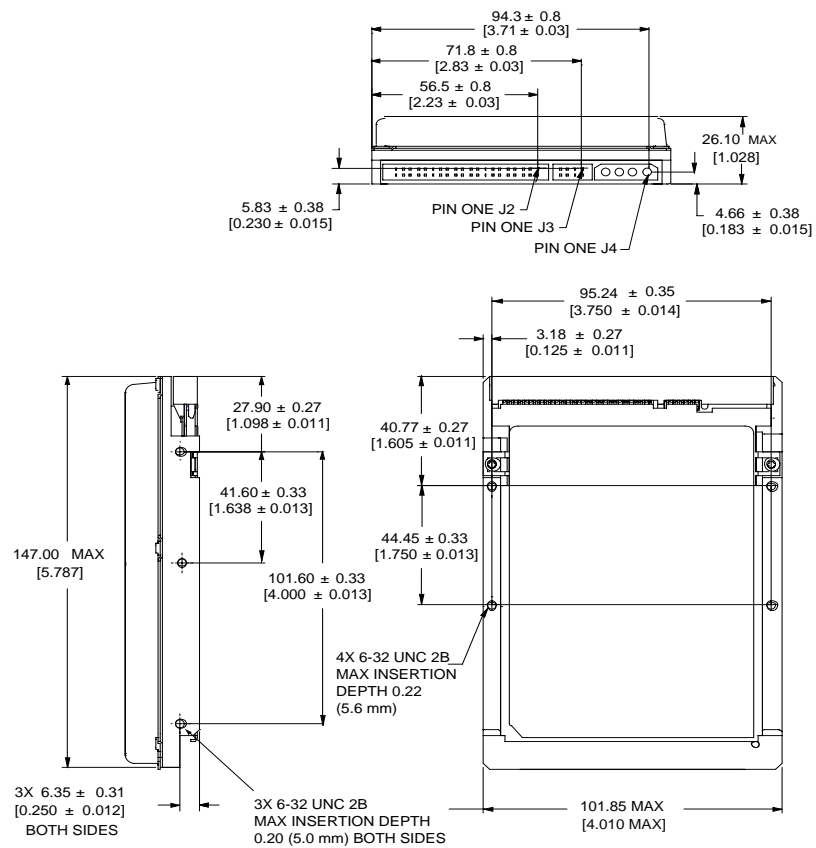

Figure 3. Mounting dimensions—top, side and end view

3.0 ATA interface

These drives use the industry-standard ATA task file interface that supports 16-bit data transfers. It supports ATA programmed input/output (PIO) modes 0, 1, 2, 3 and 4; multiword DMA modes 0, 1 and 2; and Ultra DMA modes 0, 1, 2, 3 and 4. The drive also supports the use of the IORDY signal to provide reliable high-speed data transfers.

You can use a daisy-chain cable to connect two drives to a single AT host bus. For detailed information about the ATA interface, refer to the draft of *AT Attachment with Packet Interface Extension (ATA/ATAPI-4)*, *NCITS T13 1153D*, subsequently referred to as the *Draft ATA-4 Standard*.

3.1 ATA interface signals and connector pins

Figure 4 on page 23 summarizes the signals on the ATA interface connector that the drive supports. For a detailed description of these signals, refer to the *Draft ATA-4 Standard*.

Drive pin #	Signal name	Host pin # and signal description
1	Reset	1 Hardware Reset
2	Ground	2 Ground
3	DD7	3 Host Data Bus Bit 7
4	DD8	4 Host Data Bus Bit 8
5	DD6	5 Host Data Bus Bit 6
6	DD9	6 Host Data Bus Bit 9
7	DD5	7 Host Data Bus Bit 5
8	DD10	8 Host Data Bus Bit 10
9	DD4	9 Host Data Bus Bit 4
10	DD11	10 Host Data Bus Bit 11
11	DD3	11 Host Data Bus Bit 3
12	DD12	12 Host Data Bus Bit 12
13	DD2	13 Host Data Bus Bit 2
14	DD13	14 Host Data Bus Bit 13
15	DD1	15 Host Data Bus Bit 1
16	DD14	16 Host Data Bus Bit 14
17	DD0	17 Host Data Bus Bit 0
18	DD15	18 Device Data (15:0)
19	Ground	19 Ground
20	(removed)	20 (No Pin)
21	DMARQ	21 DMA Request
22	Ground	22 Ground
23	DIOW-	23 Device I/O Write: Stop Ultra DMA Burst
24	Ground	24 Ground
25	DIOR-	25 Device I/O Read: Host Ultra DMA Ready: Host Ultra DMA Data Strobe
26	Ground	26 Ground
27	IORDY	27 I/O Channel Ready
	DDMARDY-	Device Ultra DMA Ready
	DSTROBE	Device Ultra DMA Data Strobe
28	CSEL	28 Cable Select
29	DMACK-	29 DMA Acknowledge
30	Ground	30 Ground
31	INTRQ	31 Device Interrupt
32	IOCS16-	32 Reserved
33	DA1	33 Host Address Bus Bit 1
34	PDIAG-	34 Passed Diagnostics
	CBLID-	Cable Assembly Type Identifier
35	DA0	35 Device Address (2:0)
36	DA2	36 Device Address (2:0)
37	CS0-	37 Chip Select (1:0)
38	CS1-	38 Chip Select (1:0)
39	DASP-	39 Drive Active/Slave Present
40	Ground	40 Ground

Pins 28, 34 and 39 are used for master-slave communication (details shown below).

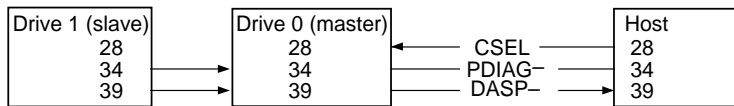

Figure 4. I/O pins and supported ATA signals

3.2 ATA Interface commands

3.2.1 Supported ATA commands

The following table lists ATA-standard commands that the drive supports. For a detailed description of the ATA commands, refer to the *Draft ATA-4 Standard*. See Section 3.2.4 on page 31 for details and subcommands used in the S.M.A.R.T. implementation.

Command name	Command code	Supported by ST317242A, ST313032A, ST310232A, ST38422A, ST34312A
ATA-standard commands		
Download Microcode	92 _H	Yes
Execute Device Diagnostics	90 _H	Yes
Flush Cache	E7 _H	Yes
Format Track	50 _H	Yes
Identify Device	EC _H	Yes
Initialize Device Parameters	91 _H	Yes
Read Buffer	E4 _H	Yes
Read DMA	C8 _H , C9 _H	Yes
Read Multiple	C4 _H	Yes
Read Sectors	20 _H , 21 _H	Yes
Read Verify Sectors	40 _H , 41 _H	Yes
Recalibrate	10 _H	Yes
Seek	70 _H	Yes
Set Features	EF _H	Yes
Set Multiple Mode	C6 _H	Yes
S.M.A.R.T.	B0 _H	Yes
Write Buffer	E8 _H	Yes

Command name	Command code	Supported by ST317242A, ST313032A, ST310232A, ST38422A, ST34312A
Write DMA	CA _H , CB _H	Yes
Write Multiple	C5 _H	Yes
Write Sectors	30 _H , 31 _H	Yes
ATA-standard power-management commands		
Check Power Mode	98 _H or E5 _H	Yes
Idle	97 _H or E3 _H	Yes
Idle Immediate	95 _H or E1 _H	Yes
Sleep	99 _H or E6 _H	Yes
Standby	96 _H or E2 _H	Yes
Standby Immediate	94 _H or E0 _H	Yes

The following commands contain drive-specific features that may not be described in the *Draft ATA-4 Standard*.

3.2.2 Identify Drive command

The Identify Drive command (command code EC_H) transfers information about the drive to the host following power up. The data is organized as a single 512-byte block of data, whose contents are shown in the table below. All reserved bits or words should be set to zero. Parameters listed with an “x” are drive-specific or vary with the state of the drive. See drive specifications in Section 1 of this manual for default parameter settings.

Note. If the alternate capacity jumper is installed on these drives, the drive capacity is reduced in word 1 to 4,092 cylinders.

Word	Description	Value
0	Configuration information: • Bit 15: 0 = ATA; 1 = ATAPI • Bit 7: removable media • Bit 6: removable controller • Bit 0: reserved	0C5A _H
1	Number of logical cylinders: 16,383 (ST317242A) 16,383 (ST313032A) 16,383 (ST310232A) 16,383 (ST38422A) 8,354 (ST34312A)	3FFF _H (ST317242A) (ST313032A) (ST310232A) (ST38422A) 20A2 _H (ST34312A)
2	ATA-reserved	0000 _H
3	Number of logical heads: 16 (ST317242A, ST313032A, ST310232A, ST38422A, ST34312A)	0010 _H
4	Retired	0000 _H
5	Retired	0000 _H
6	Number of logical sectors per logical track: 63	003F _H
7–9	Retired	0000 _H
10–19	Serial number: (20 ASCII characters, 0000 _H = none)	ASCII

Word	Description	Value
20	Retired	0000 _H
21	Retired	0400 _H
22	Obsolete	0000 _H
23–26	Firmware revision (8 ASCII character string, padded with blanks to end of string)	x.xx
27–46	Drive model number: (40 ASCII characters, padded with blanks to end of string)	ST317242A ST313032A ST310232A ST38422A or ST34312A
47	(Bits 7–0) Maximum sectors per interrupt on Read multiple and Write multiple (16)	8010 _H
48	Reserved	0000 _H
49	Standard Standby timer, IORDY supported and may be disabled	2F00 _H
50	ATA-reserved	0000 _H
51	PIO data-transfer cycle timing mode	0200 _H
52	Retired	0200 _H
53	Words 54–58, 64–70 and 88 are valid	0007 _H
54	Number of current logical cylinders	xxxx _H
55	Number of current logical heads	xxxx _H
56	Number of current logical sectors per logical track	xxxx _H
57–58	Current capacity in sectors	xxxx _H
59	Number of sectors transferred during a Read Multiple or Write Multiple command	xxxx _H

Word	Description	Value
60–61	Total number of user-addressable LBA sectors available: 33,683,328 (ST317242A) 25,434,228 (ST313032A) 20,005,650 (ST310232A) 16,841,664 (ST38422A) 8,420,832 (ST34312A)	F780 _H 0201 _H (ST317242A) 1874 _H 0184 _H (ST313032A) 4312 _H 0131 _H (ST310232A) FBC0 _H 0100 _H (ST38422A) 7DE0 _H 0080 _H (ST34312A)
62	Retired	0000 _H
63	Multiword DMA active and modes supported (see note following this table)	xx07 _H
64	Advanced PIO modes supported (modes 3 and 4 supported)	0003 _H
65	Minimum multiword DMA transfer cycle time per word (120 nsec)	0078 _H
66	Recommended multiword DMA transfer cycle time per word (120 nsec)	0078 _H
67	Minimum PIO cycle time without IORDY flow control (240 nsec)	00F0 _H
68	Minimum PIO cycle time with IORDY flow control (120 nsec)	0078 _H
69–74	ATA-reserved	0000 _H
75	Queue depth	0000 _H
76–79	ATA-reserved	0000 _H
80	Major version number	001E _H
81	Minor version number	0000 _H
82	Command sets supported	3069 _H
83	Command sets supported	4001 _H
84	Command sets support extension	4000 _H
85	Command sets enabled	30xx _H

Word	Description	Value
86	Command sets enabled	0001 _H
87	Command sets enable extension	4000 _H
88	Ultra DMA support and current mode	xx1F _H
89	Security erase time	0000 _H
90	Enhanced security erase time	0000 _H
91–127	ATA-reserved	0000 _H
128	Security status	0000 _H
129–159	Seagate-reserved	xxxx _H
160–255	ATA-reserved	0000 _H

Note. See the bit descriptions below for words 63, 88 and 93 of the Identify Drive data:

Description (if bit is set to 1)

Bit Word 63

- 0 Multiword DMA mode 0 is supported.
- 1 Multiword DMA mode 1 is supported.
- 2 Multiword DMA mode 2 is supported.
- 8 Multiword DMA mode 0 is currently active.
- 9 Multiword DMA mode 1 is currently active.
- 10 Multiword DMA mode 2 is currently active.

Bit Word 88

- 0 Ultra DMA mode 0 is supported.
- 1 Ultra DMA mode 1 is supported.
- 2 Ultra DMA mode 2 is supported.
- 3 Ultra DMA mode 3 is supported.
- 4 Ultra DMA mode 4 is supported.

- 8 Ultra DMA mode 0 is currently active.
- 9 Ultra DMA mode 1 is currently active.
- 10 Ultra DMA mode 2 is currently active.
- 11 Ultra DMA mode 3 is currently active.
- 12 Ultra DMA mode 4 is currently active.

Bit Word 93

- 13 1=80-conductor cable detected, CBLID above V_{IH}
0=40-conductor cable detected, CBLID below V_{IL}

3.2.3 Set Features command

This command controls the implementation of various features that the drive supports. When the drive receives this command, it sets BSY, checks the contents of the Features register, clears BSY and generates an interrupt. If the value in the register does not represent a feature that the drive supports, the command is aborted. Power-on default has the read look-ahead and write caching features enabled. The acceptable values for the Features register are defined as follows:

- 02_H Enable write cache (*default*).
- 03_H Set transfer mode (based on value in Sector Count register).
Sector Count register values:
 - 00_H Set PIO mode to default (PIO mode 2).
 - 01_H Set PIO mode to default and disable IORDY (PIO mode 2).
 - 08_H PIO mode 0
 - 09_H PIO mode 1
 - 0A_H PIO mode 2 (*default*)
 - 0B_H PIO mode 3
 - 0C_H PIO mode 4
 - 20_H Multiword DMA mode 0
 - 21_H Multiword DMA mode 1
 - 22_H Multiword DMA mode 2

40 _H	Ultra DMA mode 0
41 _H	Ultra DMA mode 1
42 _H	Ultra DMA mode 2
43 _H	Ultra DMA mode 3
44 _H	Ultra DMA mode 4
55 _H	Disable read look-ahead (read cache) feature.
82 _H	Disable write cache.
AA _H	Enable read look-ahead (read cache) feature (<i>default</i>).
F1 _H	Report full capacity available.

At power-on, or after a hardware reset, the default values of the features are as indicated above. A software reset also changes the features to default values.

3.2.4 S.M.A.R.T. commands

S.M.A.R.T. provides near-term failure prediction for disc drives. When S.M.A.R.T. is enabled, the drive monitors predetermined drive attributes that are susceptible to degradation over time. If self-monitoring determines that a failure is likely, S.M.A.R.T. makes a status report available to the host. Not all failures are predictable. S.M.A.R.T. predictability is limited to the attributes the drive can monitor. For more information on S.M.A.R.T. commands and implementation, see the *Draft ATA-4 Standard*.

These drives are shipped with S.M.A.R.T. features disabled. You must have a recent BIOS or software package that supports S.M.A.R.T. to enable the feature. The table below shows the S.M.A.R.T. command codes that these drives use.

Code in Features Register	S.M.A.R.T. Command	Supported by ST317242A ST313032A ST310232A ST38422A ST34312A
D0 _H	S.M.A.R.T. Read Data	Yes
D1 _H	Vendor-specific	Yes
D2 _H	S.M.A.R.T. Enable/Disable Attribute Autosave	Yes

Code in Features Register	S.M.A.R.T. Command	Supported by ST317242A ST313032A ST310232A ST38422A ST34312A
D3 _H	S.M.A.R.T. Save Attribute Values	Yes
D4 _H	S.M.A.R.T. Execute Off-line Immediate	Yes
D7 _H	Vendor-specific	Yes
D8 _H	S.M.A.R.T. Enable Operations	Yes
D9 _H	S.M.A.R.T. Disable Operations	Yes
DA _H	S.M.A.R.T. Return Status	Yes

Note. If an appropriate code is not written to the Features Register, the command is aborted and 0x04 (abort) is written to the Error register.



Seagate Technology, Inc.
920 Disc Drive, Scotts Valley, California 95066, USA

Publication Number: 20400143-001, Rev. A, Printed in USA