



.....  
***Cheetah 9LP FC Disc Drive***  
.....

***ST39102FC***  
.....

.....  
***Product Manual, Volume 1***  
.....



.....  
***Cheetah 9LP FC Disc Drive***  
.....

***ST39102FC***  
.....

.....  
***Product Manual, Volume 1***  
.....

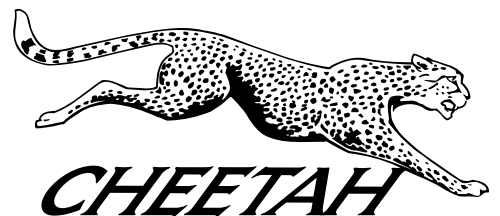

© 1997, 1998 Seagate Technology, Inc. All rights reserved  
November 1998  
Publication number: 83329350, Rev. C

Seagate, Seagate Technology, and the Seagate logo are registered trademarks of Seagate Technology, Inc. Barracuda, SeaFAX, SeaFONE, SeaBOARD, and SeaTDD are either trademarks or registered trademarks of Seagate Technology, Inc. or one of its subsidiaries. All other trademarks or registered trademarks are the property of their respective owners.

No part of this publication may be reproduced in any form without written permission from Seagate Technology, Inc.

Printed in the United States of America

# Revision status summary sheet

<b>Revision</b>	<b>Date</b>	<b>Writer/Engineer</b>	<b>Sheets Affected</b>
A	06/01/98	L. Newman/P. Kassel	1/1, v-viii, 1-64.
B	07/24/98	L. Newman/P. Kassel	4, 6, 7, 9, 10, 13, 14, 15, 19, 23, 30, 34, 38, 41, 46, 49, and 52.
C	11/05/98	L. Newman/P. Kassel	7, 13, 14, 17, 20, 30, 53, 55, 56, and 57.



## Contents

<b>1.0</b>	<b>Scope</b> .....	<b>1</b>
<b>2.0</b>	<b>Applicable standards and reference documentation</b> .....	<b>3</b>
2.1	Standards .....	3
2.1.1	Electromagnetic compatibility .....	3
2.2	Reference documents .....	4
<b>3.0</b>	<b>General description</b> .....	<b>5</b>
3.1	Standard features .....	6
3.2	Media description .....	6
3.3	Performance .....	6
3.4	Reliability .....	6
3.5	Unformatted and formatted capacities .....	7
3.6	Factory-installed accessories .....	7
3.7	Factory-installed options .....	7
3.8	User-installed accessories .....	7
<b>4.0</b>	<b>Performance characteristics</b> .....	<b>9</b>
4.1	Internal drive characteristics .....	9
4.2	Seek performance characteristics .....	9
4.2.1	Access time .....	9
4.2.2	Format command execution time for $\geq 512$ -byte sectors .....	9
4.2.3	General performance characteristics .....	10
4.3	Start/stop time .....	10
4.4	Prefetch/multi-segmented cache control .....	10
4.5	Cache operation .....	10
4.5.1	Caching write data .....	11
<b>5.0</b>	<b>Reliability specifications</b> .....	<b>13</b>
5.1	Error rates .....	13
5.1.1	Environmental interference .....	13
5.1.2	Interface errors .....	13
5.1.3	Write errors .....	13
5.1.4	Seek errors .....	13
5.2	S.M.A.R.T. ....	14
5.3	Reliability and service .....	15
5.3.1	Mean time between failure (MTBF) .....	15
5.3.2	Field failure rate vs time .....	15
5.3.3	Preventive maintenance .....	16
5.3.4	Service life .....	16
5.3.5	Service philosophy .....	16
5.3.6	Service tools .....	16
5.3.7	Product warranty .....	16
5.3.8	Hot plugging the drive .....	16
<b>6.0</b>	<b>Physical/electrical specifications</b> .....	<b>19</b>
6.1	AC power requirements .....	19
6.2	DC power requirements .....	19
6.2.1	Conducted noise immunity .....	20
6.2.2	Power sequencing .....	20
6.2.3	Current profiles .....	20
6.3	Power dissipation .....	20
6.4	Environmental limits .....	21
6.4.1	Temperature .....	21
6.4.2	Relative humidity .....	21
6.4.3	Effective altitude (sea level reference) .....	21
6.4.4	Shock and vibration .....	21

6.4.5	Air cleanliness	22
6.5	Electromagnetic susceptibility	23
6.6	Mechanical specifications	23
6.7	Acoustics	23
<b>7.0</b>	<b>Defect and error management</b>	<b>25</b>
7.1	Drive internal defects/errors	25
7.2	Drive error recovery procedures	25
7.3	FC-AL system errors	26
<b>8.0</b>	<b>Installation</b>	<b>27</b>
8.1	Drive ID/option selection	27
8.2	LED connections	27
8.2.1	J6 connector requirements	28
8.3	Drive orientation	28
8.4	Cooling	28
8.4.1	Air flow	29
8.5	Drive mounting	31
8.6	Grounding	31
<b>9.0</b>	<b>Interface requirements</b>	<b>33</b>
9.1	FC-AL features	33
9.1.1	Fibre Channel link service frames	33
9.1.2	Fibre Channel task management functions	33
9.1.3	Fibre Channel task management responses	33
9.1.4	Fibre Channel port login	34
9.1.5	Fibre Channel port login accept	35
9.1.6	Fibre Channel Process Login (PRLI)	35
9.1.7	Fibre Channel Process Accept (ACC)	35
9.1.8	Fibre Channel fabric login	36
9.1.9	Fibre Channel fabric accept login	37
9.1.10	Fibre Channel Arbitrated Loop options	38
9.2	Dual port support	38
9.3	SCSI commands supported	39
9.3.1	Inquiry data	42
9.3.2	Mode Sense data	42
9.4	Miscellaneous operating features and conditions	45
9.5	FC-AL physical interface	46
9.5.1	Physical characteristics	46
9.5.2	Connector requirements	47
9.5.3	Electrical description	48
9.5.4	Pin descriptions	48
9.5.5	FC-AL transmitters and receivers	49
9.5.6	Power	49
9.5.7	Fault LED Out	49
9.5.8	Active LED Out	49
9.5.9	Enable port bypass signals	50
9.5.10	Motor start controls	50
9.5.11	SEL_6 through SEL_0 ID lines	50
9.6	Signal characteristics	53
9.6.1	TTL input characteristics	53
9.6.2	LED driver signals	53
9.6.3	Differential PECL output	53
9.6.4	Differential PECL input	54
<b>10.0</b>	<b>Seagate Technology support services</b>	<b>55</b>



## List of Figures

Figure 1.	Cheetah 9LP FC family disc drive . . . . .	1
Figure 2.	Cheetah 9LP FC disc drive . . . . .	5
Figure 3.	Typical Cheetah 9LP FC drive +12V current profile . . . . .	20
Figure 4.	Mounting configuration dimensions . . . . .	23
Figure 5.	Physical interface . . . . .	27
Figure 6.	LED indicator connector . . . . .	28
Figure 7.	Air flow . . . . .	29
Figure 8.	PCBA temperature measurement locations . . . . .	30
Figure 9.	HDA case temperature measurement location . . . . .	30
Figure 10.	Physical interface . . . . .	46
Figure 11.	Port bypass circuit physical interconnect . . . . .	46
Figure 12.	FC-AL SCA device connector dimensions . . . . .	47
Figure 13.	J6 connector dimensions . . . . .	47
Figure 14.	FC-AL transmitters and receivers . . . . .	49
Figure 15.	Transmit eye diagram . . . . .	54
Figure 16.	Receive eye diagram . . . . .	54



## 1.0 Scope

This manual describes Seagate® Cheetah 9LP FC (Fibre Channel) disc drives.

Cheetah 9LP FC drives support the Fibre Channel Arbitrated Loop and SCSI Fibre Channel Protocol specifications to the extent described in this manual. The *Fibre Channel Interface Manual* (part number 77767496) describes the general Fibre Channel Arbitrated Loop characteristics of this and other Seagate Fibre Channel drives.

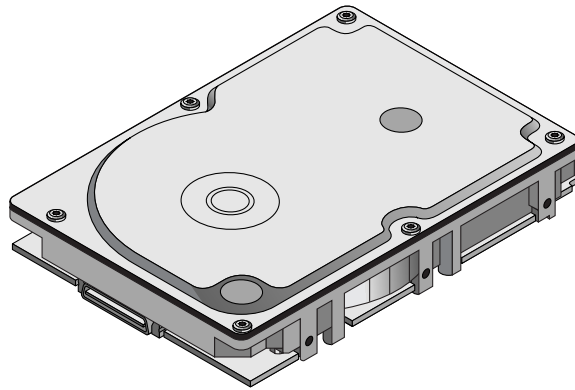

Figure 1. Cheetah 9LP FC family disc drive



## 2.0 Applicable standards and reference documentation

The drive has been developed as a system peripheral to the highest standards of design and construction. The drive depends upon its host equipment to provide adequate power and environment in order to achieve optimum performance and compliance with applicable industry and governmental regulations. Special attention must be given in the areas of safety, power distribution, shielding, audible noise control, and temperature regulation. In particular, the drive must be securely mounted in order to guarantee the specified performance characteristics. Mounting by bottom holes must meet the requirements of Section 8.5.

### 2.1 Standards

The Cheetah 9LP FC family complies with Seagate standards as noted in the appropriate sections of this manual and the Seagate *Fibre Channel Interface Manual*, part number 77767496.

The Cheetah 9LP FC disc drive is a UL recognized component per UL1950, CSA certified to CAN/CSA C22.2 No. 950-95, and VDE certified to VDE 0805 and EN60950.

#### 2.1.1 Electromagnetic compatibility

The drive, as delivered, is designed for system integration and installation into a suitable enclosure prior to use. As such the drive is supplied as a subassembly and is not subject to Subpart B of Part 15 of the FCC Rules and Regulations nor the Radio Interference Regulations of the Canadian Department of Communications.

The design characteristics of the drive serve to minimize radiation when installed in an enclosure that provides reasonable shielding. As such, the drive is capable of meeting the Class B limits of the FCC Rules and Regulations of the Canadian Department of Communications when properly packaged. However, it is the user's responsibility to assure that the drive meets the appropriate EMI requirements in their system. Shielded I/O cables may be required if the enclosure does not provide adequate shielding. If the I/O cables are external to the enclosure, shielded cables should be used, with the shields grounded to the enclosure and to the host controller.

##### 2.1.1.1 Electromagnetic susceptibility

As a component assembly, the drive is not required to meet any susceptibility performance requirements. It is the responsibility of those integrating the drive within their systems to perform those tests required and design their system to ensure that equipment operating in the same system as the drive or external to the system does not adversely affect the performance of the drive. See Section 5.1.1 on page 13 and Table 1, DC power requirements, on page 19.

Electromagnetic compliance

Seagate uses an independent laboratory to confirm compliance with the directives/standards for CE Marking and C-Tick Marking. The drive was tested in a representative system for typical applications. The selected system represents the most popular characteristics for test platforms. The system configurations include:

- 486, Pentium, and PowerPC microprocessors
- 3.5-inch floppy disc drive
- Keyboard
- Monitor/display
- Printer
- External modem
- Mouse

Although the test system with this Seagate model complies with the directives/standards, we cannot guarantee that all systems will comply. The computer manufacturer or system integrator shall confirm EMC compliance and provide the appropriate marking for their product.

#### Electromagnetic compliance for the European Union

If this model has the CE Marking it complies with the European Union requirements of the Electromagnetic Compatibility Directive 89/336/EEC of 03 May 1989 as amended by Directive 92/31/EEC of 28 April 1992 and Directive 93/68/EEC of 22 July 1993.

## Australian C-Tick

If this model has the C-Tick Marking it complies with the Australia/New Zealand Standard AS/NZS3548 1995 and meets the Electromagnetic Compatibility (EMC) Framework requirements of Australia's Spectrum Management Agency (SMA).

## 2.2 Reference documents

*Cheetah 9LP FC Installation Guide*

Seagate part number: 83329340

*Fibre Channel Interface Manual*

Seagate part number: 77767496

### ANSI Fibre Channel Documents

X3.230-1994	FC Physical and Signaling Interface (FC-PH)
X3.297.1997	FC-PH-2 Fibre Channel Physical and Signaling Interface-2
X3.303.199X	FC-PH-3 Fibre Channel Physical and Signaling Interface-3
X3.272-1996	FC Arbitrated Loop (FC-AL)
X3.269-1996	Fibre Channel Protocol for SCSI (FCP)
NCITS TR-19	Private Loop SCSI Direct Attach
NCITS TR-20	Fabric Loop Attachment (FC-FLA)
SFF-8045	Specification for 40-pin SCA-2 Connector with Parallel Selection.
SFF-8067	Specification for 40-pin SCA-2 Connector with Bidirectional Enclosure Services Interface.

### ANSI Small Computer System Interface (SCSI) Documents

X3.131-1994	(SCSI-2)
X3.270-199X	(SCSI-3) Architecture Model
X3.XXX-199X	(SCSI-3) Enclosure Services
30553-001	Specification for Acoustic Test Requirement and Procedures

In case of conflict between this document and any referenced document, this document takes precedence.

### 3.0 General description

Cheetah™ 9LP FC drives are random access storage devices designed to support the Fibre Channel Arbitrated Loop (FC-AL) and SCSI Fibre Channel Protocol as described in the ANSI specifications, this document, and the *Fibre Channel Interface Manual* (part number 77767496) which describes the general interface characteristics of this drive. ST39102FC drives are classified as intelligent peripherals and provide level 2 conformance (highest level) with the ANSI SCSI-1 standard.

You can view the Fibre Channel interface as a transport vehicle for the supported command set (ST39102FC drives use the SCSI command set). In fact, the Fibre Channel interface is unaware of the content or meaning of the information being transported. It simply packs the SCSI commands in frames, transports them to the appropriate devices, and provides error checking to ensure that the information reaches its destination accurately. Refer to the documents referenced in Section 2.2 if you require additional information about the Fibre Channel interface, FC-AL topology, or the SCSI fibre channel protocol.

The head and disc assembly (HDA) is environmentally sealed at the factory. Air recirculates within the HDA through a non-replaceable filter to maintain a contamination-free HDA environment.

See Figure 2 for an exploded view of the drive. Never disassemble the HDA. This exploded view is for information only. Do not attempt to service items in the sealed enclosure (heads, media, actuator, etc.) as this requires special facilities. The drive contains no parts replaceable by the user and opening the HDA for any reason voids your warranty.

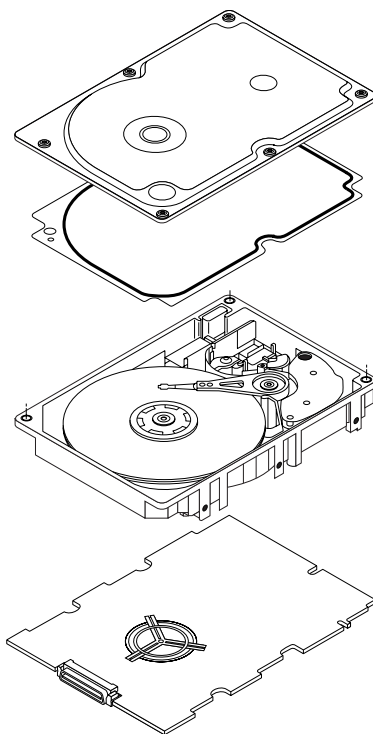

**Figure 2. Cheetah 9LP FC disc drive**

Cheetah 9LP FC drives use a dedicated landing zone at the innermost radius of the media to eliminate the possibility of destroying or degrading data by landing in the data zone. The heads automatically go to the landing zone when power is removed from the drive.

An automatic shipping lock prevents potential damage to the heads and discs that results from movement during shipping and handling. The shipping lock disengages and the head load process begins when power is applied to the drive.

The drives also use a high-performance actuator assembly design that provides excellent performance with minimum power dissipation.

### 3.1 Standard features

Cheetah 9LP FC drives have the following standard features:

- Integrated dual port FC-AL controller
- Concurrent dual port transfers
- Support for FC arbitrated loop and private and public loop attachment
- Differential copper FC drivers and receivers
- Downloadable firmware using the FC-AL interface
- Drive selection ID and configuration options are set on the FC-AL backpanel or through interface commands. Jumpers are not used on the drive.
- Fibre Channel worldwide name uniquely identifies the drive and each port
- User-selectable logical block size (512 to 4,096 bytes per logical block)
- Selectable frame sizes from 128 to 2,112 bytes
- Industry standard 3.5-inch low profile form factor dimensions
- Programmable logical block reallocation scheme
- Flawed logical block reallocation at format time
- Programmable auto write and read reallocation
- Reed-Solomon error correction code
- Sealed head and disc assembly (HDA)
- No preventive maintenance or adjustments required
- Dedicated head landing zone
- Automatic shipping lock
- Embedded Grey Code track address to eliminate seek errors
- Self-diagnostics performed at power on
- 1:1 interleave
- Zone bit recording (ZBR)
- Vertical, horizontal, or top down mounting
- Dynamic spindle brake
- 1,024 Kbyte data buffer. See Section 4.5
- Embedded servo design
- Supports SCSI enclosure services via interface connector
- 128-deep task set (queue)
- Supports up to 32 initiators
- Reallocation of defects on command (Post Format)
- Fibre Channel interface transports SCSI protocol
- Supports SCSI Enclosure Services through the interface connector

### 3.2 Media description

The media used on the drive has a diameter of approximately 84 mm (approximately 3.4 inches). The aluminum substrate is coated with a thin film magnetic material, overcoated with a proprietary protective layer for improved durability and environmental protection.

### 3.3 Performance

- Programmable multi-segmentable cache buffer
- 106 Mbytes/sec maximum instantaneous data transfers per port.
- 10,025 RPM spindle; average latency = 2.99 msec
- Command queuing of up to 128 commands
- Background processing of queue
- Supports start and stop commands
- Adaptive seek velocity; improved seek performance

### 3.4 Reliability

- 1,000,000 hour MTBF
- LSI circuitry



- Balanced low mass rotary voice coil actuator
- Self-Monitoring Analysis and Reporting Technology (S.M.A.R.T.)
- Dithering

### 3.5 Unformatted and formatted capacities

Standard OEM models are formatted to 512 bytes per block. You can order other capacities by requesting a different sparing scheme and logical block size.

The standard OEM model capacities are listed below.

	<b>Formatted</b>	<b>Unformatted</b>
ST39102FC	9.105 Gbytes	11.27 Gbytes

Users having the necessary equipment may modify the data block size before issuing a format command and obtain different formatted capacities than those listed. The ST39102FC uses a zone sparing scheme. The drive is divided into frequency zones with a variable number of spares in each zone.

### 3.6 Factory-installed accessories

OEM standard drives are shipped with the *Cheetah 9LP FC Installation Guide* (part number 83329340).

### 3.7 Factory-installed options

You may order the following items which are incorporated at the manufacturing facility during production or packaged before shipping:

- Single-unit shipping pack. The drive is normally shipped in bulk packaging to provide maximum protection against transit damage. Units shipped individually require additional protection as provided by the single unit shipping pack. Users planning single unit distribution should specify this option.

### 3.8 User-installed accessories

The following accessories are available. All kits may be installed in the field.

- Evaluation kit, part number 73473641.  
This kit provides an adapter card ("T-card") to allow cable connections for two FC ports and DC power. Two twin axial cables, 6 feet in length, are included for the input and output connections to the FC interface.



## 4.0 Performance characteristics

This section provides detailed information concerning performance-related characteristics and features of Cheetah 9LP FC drives.

### 4.1 Internal drive characteristics

		ST39102FC
Drive capacity		11.27 ..... Gbytes (unformatted)
		9.105 ..... Gbytes (formatted with 512-byte logical blocks)
Read/write data heads		12
Bytes per track		104,840 - 159,008 .... Bytes (average, unformatted)
Bytes per surface		939 ..... Mbytes (unformatted)
Cylinders/tracks per surface		6,962 ..... Tracks (user accessible)
Tracks per inch		8,962 ..... TPI
Internal data rate		152-231 ..... Mbits/sec (variable with zone)
Disc rotation speed		10,025 ..... rpm ( $\pm$ 0.5%)
Avg rotational latency		2.99 ..... msec

### 4.2 Seek performance characteristics

See Section 9.5, "FC-AL physical interface" on page 46 and the *Fibre Channel Interface Manual* (part number 77767496) for additional timing details.

#### 4.2.1 Access time

		Including controller overhead <sup>1, 2</sup> (msec)	
		Read	Write
Average	Typical <sup>3,4</sup>	5.4	6.2
Single track	Typical <sup>3,4</sup>	0.8	1.1
Full stroke	Typical <sup>3,4</sup>	<12.2	<13.2

1. Execution time measured from receipt of the FCP Command to the FCP Response.
2. Assumes no errors and no sector has been relocated.
3. Typical access times are measured under nominal conditions of temperature, voltage, and horizontal orientation as measured on a representative sample of drives.
4. Access time = controller overhead + average seek time.  
Access to data = controller overhead + average seek time + latency time.

#### 4.2.2 Format command execution time for $\geq$ 512-byte sectors

		ST39102FC
Maximum (with verify)		30 minutes
Maximum (without verify)		15 minutes

### 4.2.3 General performance characteristics

	ST39102FC
Minimum sector interleave	1 to 1
Data buffer to/from disc media (one 512-byte logical block)*	
Minimum	19.0 MBytes/sec
Average	23.9 MBytes/sec
Maximum	28.4 MBytes/sec
Fibre Channel Interface maximum instantaneous transfer rate	106 Mbytes/sec*per port (dual port = 212 Mbytes/sec*)
Logical block sizes	
Default is 512-byte data blocks	
Variable 512 to 4,096 bytes per sector in multiples of 4 bytes.	
Read/write consecutive sectors on a track	Yes
Overhead time for head switch in sequential mode	0.8 msec
Overhead time for one track cylinder switch in sequential mode	1.2 msec (typical)
Average rotational latency	2.99 msec

\*Assumes no errors and no relocated logical blocks. Rate measured from the start of the first logical block transfer to or from the host.

### 4.3 Start/stop time

If the Motor Start option is disabled, the drive becomes ready within 30 seconds after DC power is applied. If a recoverable error condition is detected during the start sequence, the drive executes a recovery procedure and the time to become ready may exceed 30 seconds. During the start sequence, the drive responds to some commands over the FC-AL interface. Stop time is less than 30 seconds (maximum) from removal of DC power.

If the Motor Start option is enabled, the internal controller accepts the commands listed in the *Fibre Channel Interface Manual* less than 3 seconds after DC power has been applied. After the Motor Start command has been received, the drive becomes ready for normal operations within 30 seconds (excluding the error recovery procedure). The Motor Start command can also be used to command the drive to stop the spindle.

There is no power control switch on the drive.

### 4.4 Prefetch/multi-segmented cache control

The drive provides a prefetch/multi-segmented cache algorithm that in many cases can enhance system performance. To select this feature the host sends the Mode Select command with the proper values in the applicable bytes in page 08h. Default is prefetch and read cache enabled.

If the Prefetch feature is enabled, data in contiguous logical blocks on the disc immediately beyond that which was requested by a Read command are retrieved and stored in the buffer for immediate transfer from the buffer to the host on subsequent Read commands that request those logical blocks (this is true even if cache operation is disabled). To enable Prefetch, use Mode Select page 08h, byte 12, bit 5 (Disable Read Ahead - DRA bit). DRA bit = 0 enables prefetch.

Since data that is prefetched replaces data already in some buffer segments, the host can limit the amount of prefetch data to optimize system performance. The Max Prefetch field (bytes 8 and 9) limits the amount of prefetch. The drive does not use the Prefetch Ceiling field (bytes 10 and 11).

### 4.5 Cache operation

**Note.** Refer to the *Fibre Channel Interface Manual* for more detail concerning the cache bits.

Of the 1,024 Kbytes physical buffer space in the drive, 967.5 Kbytes can be used as a cache. The cache can be divided into logical segments from which data is read and to which data is written.

The drive keeps track of the logical block addresses of the data stored in each segment of the cache. If the cache is enabled (see RCD bit in the *Fibre Channel Interface Manual*), data requested by the host with a read command is retrieved from the cache, if possible, before any disc access is initiated. Data in contiguous logical blocks immediately beyond that requested by the Read command can be retrieved and stored in the cache for immediate transfer to the initiator on subsequent read commands. This is referred to as the prefetch operation. Since data that is prefetched may replace data already in the cache segment, an initiator can limit the amount of prefetch data to optimize system performance. The drive never prefetches more sectors than the number specified in bytes 8 and 9 of Mode page 08h. If the cache is not enabled, 967.5 Kbytes of the buffer are used as a circular buffer for read/writes, with no prefetch operation and no segmented cache operation.

The following is a simplified description of the prefetch/cache operation:

**Case A**—read command is received and the first logical block is already in cache:

1. Drive transfers to the initiator the first logical block requested plus all subsequent contiguous logical blocks that are already in the cache. This data may be in multiple segments.
2. When a requested logical block is reached that is not in any segment, the drive fetches it and any remaining requested logical block addresses from the disc and puts them in a segment of the cache. The drive transfers the remaining requested logical blocks from the cache to the initiator in accordance with the “buffer-full” ratio specification given in Mode Select Disconnect/Reconnect parameters, page 02h.
3. The drive prefetches additional logical blocks contiguous to those transferred in step 2 above and stores them in the segment. The drive stops filling the segment when the maximum prefetch value has been transferred.

**Case B**—read command is received and the first logical block address requested is not in any segment of the cache.

1. The drive fetches the requested logical blocks from the disc and transfers them into a segment, and then from there to the initiator in accordance with the “buffer-full” ratio specification given in Mode Select Disconnect/Reconnect parameters, page 02h.
2. The drive prefetches additional logical blocks contiguous to those transferred in Case A, step 2 above and stores them in the segment. The drive stops filling the segment when the maximum prefetch value has been transferred.

During a prefetch, the drive crosses a cylinder boundary to fetch data only if the Discontinuity (DISC) bit is set to 1 in bit 4 of byte 2 of the Mode Select parameters page 08h. Default is zero for bit 4.

Each cache segment is actually a self-contained circular buffer whose length is an integer number of logical blocks. The wrap-around capability of the individual segments greatly enhances the cache's overall performance, allowing a wide range of user-selectable configurations. The drive supports operation of any integer number of segments from 1 to 16. Divide the 967.5 Kbytes in the buffer by the number of segments to get the segment size. Default is 3 segments.

**Note.** The size of each segment is not reported by Mode Sense command page 08h, bytes 14 and 15. The value 0XFFFF is always reported regardless of the actual size of the segment. Sending a size specification using the Mode Select command (bytes 14 and 15) does not set up a new segment size. If the STRICT bit in Mode page 00h (byte 2, bit 1) is set to one, the drive responds as it does for any attempt to change an unchangeable parameter.

#### 4.5.1 Caching write data

Write caching is a write operation by the drive that makes use of a drive buffer storage area where the data to be written to the medium is stored while the drive performs the Write command.

Write caching is enabled independently of read caching. Write caching is enabled by default. To disable the write cache, use the Write Caching Enable (WCE) bit.

For write caching, the same buffer space and segmentation is used as set up for read functions. When a write command is issued, the cache is first checked to see if any logical blocks that are to be written are already

stored in the cache from a previous read or write command. If there are, the respective cache segments are cleared. The new data is cached for subsequent read commands.

If a 10-byte CDB Write command (2Ah) is issued with the data page out (DPO) bit set to 1, no write data is cached, but the cache segments are still checked and cleared, if need be, for any logical blocks that are being written.

If the number of write data logical blocks exceeds the size of the segment being written into when the end of the segment is reached, the data is written into the beginning of the same cache segment, overwriting the data that was written there at the beginning of the operation. However, the drive does not overwrite data that has not yet been written to the medium.

## 5.0 Reliability specifications

The following reliability specifications assume correct host and drive operational interface, including all interface timings, power supply voltages, and environmental requirements.

Seek error rate:	Less than 10 errors in $10^8$ seeks
Recoverable media error rate (using OEM default settings):	Less than 10 errors in $10^{12}$ bits transferred
Unrecovered media data:	Less than 1 sector in $10^{15}$ bits transferred
Miscorrected media data:	Less than 1 sector in $10^{21}$ bits transferred
Interface error rate:	Less than 1 error in $10^{12}$ bits transferred with minimum receive eye. Less than 1 error in $10^{14}$ bits transferred with typical receive eye. See Section 9.6.4, "Differential PECL input." on page 54
MTBF:	1,000,000 hours
Service life:	5 years
Preventive maintenance:	None required

### 5.1 Error rates

The error rates stated in this manual assume the following:

- The drive is operated in accordance with this manual using DC power as defined in paragraph 6.2, "DC power requirements."
- The drive has been formatted with the FC-AL Format command.
- Errors caused by media defects or host system failures are excluded from error rate computations.

#### 5.1.1 Environmental interference

When evaluating systems operation under conditions of electromagnetic interference (EMI), the performance of the drive within the system is considered acceptable if the drive does not generate an unrecoverable condition.

An unrecoverable error, or condition, is defined as one that:

- is not detected and corrected by the drive itself
- is not detected from the error or fault status provided through the drive or FC-AL interface
- is not recovered by normal drive or system recovery procedures without operator intervention

#### 5.1.2 Interface errors

An interface error is defined as a failure of the receiver on a port to recover the data as transmitted by the device port connected to the receiver. The error may be detected as a running disparity error, illegal code, loss of word sync, or CRC error. The total error rate for a loop of devices is the sum of the individual device error rates.

#### 5.1.3 Write errors

Write errors can occur as a result of media defects, environmental interference, or equipment malfunction. Therefore, write errors are not predictable as a function of the number of bits passed.

If an unrecoverable write error occurs because of an equipment malfunction in the drive, the error is classified as a failure affecting MTBF. Unrecoverable write errors are those that cannot be corrected within two attempts at writing the record with a read verify after each attempt (excluding media defects).

#### 5.1.4 Seek errors

A seek error is defined as a failure of the drive to position the heads to the addressed track. If the error recovery fails, a seek positioning error (15h) is reported with a Medium (03h) or Hardware Error (04h) reported in the sense key. This is an unrecoverable seek error. Unrecoverable seek errors are classified as failures for MTBF calculations.

## 5.2 S.M.A.R.T.

S.M.A.R.T. is an acronym for Self-Monitoring Analysis and Reporting Technology. This technology is intended to recognize conditions that indicate imminent drive failure and is designed to provide sufficient warning of a failure to allow you to back up the data before an actual failure occurs.

**Note.** The drive's firmware monitors specific attributes for degradation over time but can't predict instantaneous drive failures.

Each monitored attribute has been selected to monitor a specific set of failure conditions in the operating performance of the drive and the thresholds are optimized to minimize "false" and "failed" predictions.

### Controlling S.M.A.R.T.

The operating mode of S.M.A.R.T. is controlled by the DEXCPT and PERF bits on the Informational Exceptions Control mode page (1Ch). Use the DEXCPT bit to enable or disable the S.M.A.R.T. feature. Setting the DEXCPT bit disables all S.M.A.R.T. functions. When enabled, S.M.A.R.T. collects on-line data as the drive performs normal read and write operations. When the PERF bit is set, the drive is considered to be in "On-line Mode Only" and will not perform off-line functions.

You can measure off-line attributes and force the drive to save the data by using the Rezero Unit command. Forcing S.M.A.R.T. resets the timer so that the next scheduled interrupt is in two hours.

You can interrogate the drive through the host to determine the time remaining before the next scheduled measurement and data logging process occurs. To accomplish this, issue a Log Sense command to log page 0x3E. This allows you to control when S.M.A.R.T. interruptions occur. Forcing S.M.A.R.T. with the RTZ command resets the timer.

### Performance impact

S.M.A.R.T. attribute data is saved to the disc so that the events that caused a predictive failure can be recreated. The drive measures and saves parameters once every two hours subject to an idle period on the FC-AL bus. The process of measuring off-line attribute data and saving data to the disc is uninterruptable. The maximum on-line only (DEXCPT = 0; PERF = 1) processing delay is 35 ms. The maximum fully-enabled (DEXCPT = 0, PERF = 0) processing delay is 220 ms.

### Reporting control

Reporting is controlled by the MRIE bits in the Informational Exceptions Control mode page (1Ch). Subject to the reporting method, the firmware will issue to the host an 01-5Dxx sense code. The error code is preserved through bus resets and power cycles.

### Determining rate

S.M.A.R.T. monitors the rate at which errors occur and signals a predictive failure if the rate of degraded errors increases to an unacceptable level. To determine rate, error events are logged and compared to the number of total operations for a given attribute. The interval defines the number of operations over which to measure the rate. The counter that keeps track of the current number of operations is referred to as the Interval Counter.

S.M.A.R.T. measures error rates. All errors for each monitored attribute are recorded. A counter keeps track of the number of errors for the current interval. This counter is referred to as the Failure Counter.

Error rate is the number of errors per operation. The algorithm that S.M.A.R.T. uses to record rates of error is to set thresholds for the number of errors and their interval. If the number of errors exceeds the threshold before the interval expires, the error rate is considered to be unacceptable. If the number of errors does not exceed the threshold before the interval expires, the error rate is considered to be acceptable. In either case, the interval and failure counters are reset and the process starts over.

### Predictive failures

S.M.A.R.T. signals predictive failures when the drive is performing unacceptably for a period of time. The firmware keeps a running count of the number of times the error rate for each attribute is unacceptable. To accomplish this, a counter is incremented each time the error rate is unacceptable and decremented (not to exceed zero) whenever the error rate is acceptable. If the counter continually increments such that it reaches the predictive threshold, a predictive failure is signaled. This counter is referred to as the Failure History Counter. There is a separate Failure History Counter for each attribute.



### 5.3 Reliability and service

The reliability of Cheetah 9LP FC disc drives can be enhanced by ensuring that the drive receives adequate cooling. This section provides recommended air-flow information, temperature measurements, and other information, which you can use to enhance the service life of the drive.

#### 5.3.1 Mean time between failure (MTBF)

The production disc drive achieves an MTBF of 1,000,000 hours when operated in an environment that ensures the case temperatures specified in Section 8.4.1 are not exceeded. Short-term excursions up to the specification limits of the operating environment will not affect MTBF performance. Operating the drive at case temperatures above these values will adversely affect the drive's ability to meet specifications. See Section 6.4, "Environmental limits" on page 21.

The following expression defines MTBF:

$$\text{MTBF} = \frac{\text{Estimated power-on operating hours in the period}}{\text{Number of drive failures in the period}}$$

Estimated power-on operating hours means the estimated total power-on hours for all drives in service. Drive failure means any stoppage or substandard performance caused by drive malfunction.

MTBF is based on the following criteria:

- 8,760 power-on hours per year
- 250 average on/off cycles per year
- Read/seek/write operation during 20% of power-on hours
- Operating at nominal voltages
- System provides adequate cooling to ensure the case temperatures specified in Figures 8 and 9 are not exceeded. Short term excursions up to the specification limits of the operating environment will not affect MTBF performance.

Data is calculated on a rolling-average base for a minimum period of six months.

A S.M.A.R.T. predictive failure indicates that the drive is deteriorating to an imminent failure and is considered an MTBF hit.

Drive failure means any stoppage or substandard performance caused by drive malfunction.

#### 5.3.2 Field failure rate vs time

The expected field failure rate is listed below. Drive utilization will vary. An estimate range of utilization is:

- 720 power-on hours (POH) per month
- 250 on/off cycles per year
- Read/seek/write operation 20% of POH
- System provides adequate cooling to ensure the case temperatures specified in Figures 8 and 9 are not exceeded. Short term excursions up to the specification limits of the operating environment will not affect MTBF performance.

Month	Parts per million (PPM)
1	2,364
2	1,422
3	1,403
4	1,391
5	1,317
6	1,255
7	1,162
8+	1,025

Failure rate is calculated as follows:

- No system-induced failures counted
- PPM targets include 30% no defect found and handling failures
- Based on 1,000,000 MTBF and 720 POH per month
- Month 1's rate includes a 300 PPM installation failure

### **5.3.3 Preventive maintenance**

No routine scheduled preventive maintenance is required.

### **5.3.4 Service life**

The drive has a useful service life of five years. Depot repair or replacement of major parts is permitted during the lifetime.

### **5.3.5 Service philosophy**

Special equipment is required to repair the drive HDA. To achieve the above service life, repairs must be performed only at a properly equipped and staffed Seagate service and repair facility. Troubleshooting and repair of PCBs in the field is not recommended because of the extensive diagnostic equipment required for effective servicing. The drive warranty is voided if the HDA is opened.

### **5.3.6 Service tools**

No special tools are required for site installation or recommended for site maintenance. The depot repair philosophy of the drive precludes the necessity for special tools. Field repair of the drive is not practical because users cannot purchase individual parts for the drive.

### **5.3.7 Product warranty**

Beginning on the date of shipment to the customer and continuing for a period of five years, Seagate warrants that each product (including components and subassemblies) that fails to function properly under normal use due to defect in materials or workmanship or due to nonconformance to the applicable specifications will be repaired or replaced, at Seagate's option and at no charge to the customer, if returned by customer at customer's expense to Seagate's designated facility in accordance with Seagate's warranty procedure. Seagate will pay for transporting the repair or replacement item to the customer. For more detailed warranty information, refer to the standard terms and conditions of purchase for Seagate products on your purchase documentation.

The remaining warranty for a particular drive can be determined by calling Seagate Customer Service at 1-800-468-3472. You can also determine remaining warranty using the Seagate web site ([www.seagate.com](http://www.seagate.com)). The drive serial number is required to determine remaining warranty information.

## **Shipping**

When transporting or shipping a drive, use only a Seagate-approved container. Keep your original box. Seagate approved containers are easily identified by the Seagate Approved Package label. Shipping a drive in a non-approved container voids the drive warranty.

Seagate repair centers may refuse receipt of components improperly packaged or obviously damaged in transit. Contact your authorized Seagate distributor to purchase additional boxes. Seagate recommends shipping by an air-ride carrier experienced in handling computer equipment.

## **Product repair and return information**

Seagate customer service centers are the only facilities authorized to service Seagate drives. Seagate does not sanction any third-party repair facilities. Any unauthorized repair or tampering with the factory seal voids the warranty.

### **5.3.8 Hot plugging the drive**

Inserting and removing the drive on the FC-AL will interrupt loop operation. The interruption occurs when the receiver of the next device in the loop must synchronize to a different input signal. FC error detection mechanisms, character sync, running disparity, word sync, and CRC are able to detect any error. Recovery is initiated based on the type of error.

The disc drive defaults to the FC-AL Monitoring state, Pass-through state, when it is powered-on by switching the power or hot plugged. The control line to an optional port bypass circuit (external to the drive), defaults to the Enable Bypass state. If the bypass circuit is present, the next device in the loop will continue to receive the output of the previous device to the newly inserted device. If the bypass circuit is not present, loop operation is temporarily disrupted until the next device starts receiving the output from the newly inserted device and regains synchronization to the new input.

The Pass-through state is disabled while the drive performs self test of the FC interface. The control line for an external port bypass circuit remains in the Enable Bypass state while self test is running. If the bypass circuit is present, loop operation may continue. If the bypass circuit is not present, loop operation will be halted while the self test of the FC interface runs.

When the self test completes successfully, the control line to the bypass circuit is disabled and the drive enters the FC-AL Initializing state. The receiver on the next device in the loop must synchronize to output of the newly inserted drive.

If the self-test fails, the control line to the bypass circuit remains in the Enable Bypass state.

**Note.** It is the responsibility of the systems integrator to assure that no temperature, energy, voltage hazard, or ESD potential hazard is presented during the hot connect/disconnect operation. Discharge the static electricity from the drive carrier prior to inserting it into the system.

**Caution.** The drive motor must come to a complete stop prior to changing the plane of operation. This time is required to insure data integrity.



## 6.0 Physical/electrical specifications

This section provides information relating to the physical and electrical characteristics of the drive.

### 6.1 AC power requirements

None.

### 6.2 DC power requirements

The voltage and current requirements for a single drive are shown below. On-board +3.3V current is derived entirely from the +5V supply. Values indicated apply at the drive connector. Parameters, others than spindle start, are measured after a 10-minute warm-up.

**Table 1: DC power requirements**

Voltage regulation	Notes [5]	ST39102FC	
		+5V ±5% (Amps)	+12V ±5% <sup>[2]</sup> (Amps)
Avg idle current	[1] [8]	0.692	0.844
Max start current (peak DC)	[3] [6]	0.812	2.084
Delayed motor start (max)	[1] [4]	0.755	0.325
Operating current:			
Typical	[1] [7]	0.736	0.995
Maximum	[1]	0.817	1.117
Max (peak)		1.133	2.850

- [1] Measured with average reading DC ammeter. Instantaneous +12V current peaks will exceed these values.
- [2] A -10% tolerance is allowed during initial spindle start but must return to ±5% before reaching 10,000 RPM. The ±5% must be maintained after the drive signifies that its power-up sequence has been completed and that the drive is able to accept selection by the host initiator.
- [3] See +12V current profile in Figure 3.
- [4] This condition occurs when the Motor Start option is enabled and the drive has not yet received a Start Motor command.
- [5] See paragraph 6.2.1, "Conducted noise immunity." Specified voltage tolerance includes ripple, noise, and transient response.
- [6] At power up, the motor current regulator limits the 12 volt current to an average value of less than 2.1 amperes, although instantaneous peaks may exceed this value. These peaks should measure 5 msec duration or less.
- [7] Operating condition is defined as a third stroke seek at OD and Read One track. Command issued every 42 ms.
- [8] During idle, the heads are relocated every 60 seconds to a random location within the band from track 0 to one-fourth of maximum track. This will result in a random variation in the +12 volt idle current of 0.0152 Amperes (0.182 Watts).

#### General DC power requirement notes.

1. Minimum current loading for each supply voltage is not less than 2% of the maximum operating current shown.
2. The +5V and +12V supplies should employ separate ground returns.
3. Where power is provided to multiple drives from a common supply, careful consideration for individual drive power requirements should be noted. Where multiple units are powered on simultaneously, the peak starting current must be available to each device.

### 6.2.1 Conducted noise immunity

Noise is specified as a periodic and random distribution of frequencies covering a band from DC to 10 MHz. Maximum allowed noise values given below are peak-to-peak measurements and apply at the drive power connector.

	+5V	+12V (with spindle motor not running)
0 to 100 kHz	150mV	150mV
100 kHz to 10 MHz	100mV	100mV

### 6.2.2 Power sequencing

The drive does not require power sequencing. The drive protects against inadvertent writing during power-up and down.

### 6.2.3 Current profiles

Figure 3 identifies the drive +12V current profile. The current during the various times is as shown:

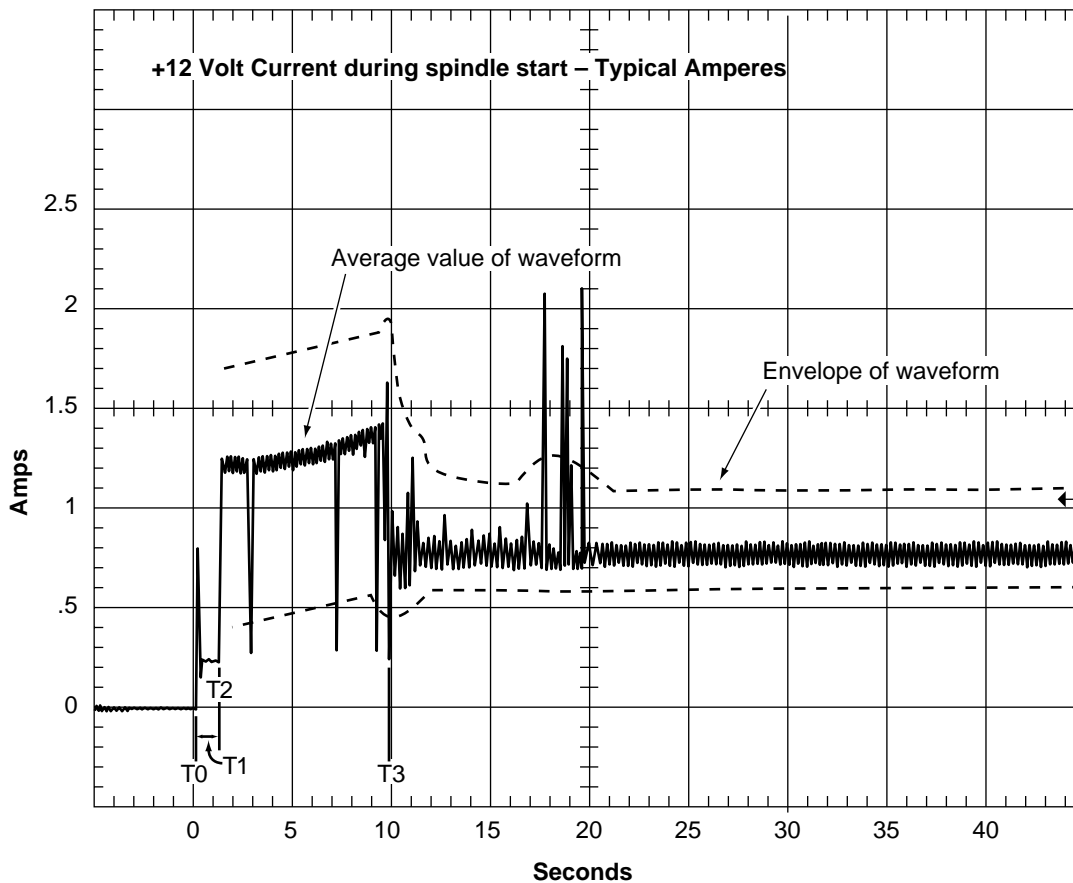

**Figure 3. Typical Cheetah 9LP FC drive +12V current profile**

- T0 Power is applied to the drive.
- T1 Controller self-tests are performed.
- T2 Spindle begins to accelerate under current limiting after performing internal diagnostics.
- T3 Spindle is up to speed and the Head-Arm restraint is unlocked.

**Note:** All times and currents are typical. See Table 1 for maximum current requirements.

### 6.3 Power dissipation

Typical seek power dissipation is 15.6 watts (53 BTUs per hour) of DC power average at nominal voltages. Typical power dissipation under idle conditions is 13.7 watts (47 BTUs per hour).

## 6.4 Environmental limits

Temperature and humidity values experienced by the drive must be such that condensation does not occur on any drive part. Altitude and atmospheric pressure specifications are referenced to a standard day at 58.7°F (14.8°C). Maximum wet bulb temperature is 82°F (28°C).

### 6.4.1 Temperature

#### a. Operating

The MTBF specification for the drive is based on operating at a local ambient temperature of 86°F (30°C). Occasional excursions to drive ambient temperatures to 122°F (50°C) or 41°F (5°C) may occur without impact to specified MTBF. The enclosure for the drive should be designed such that the PCBA and case temperatures listed in Section 8.4.1 and illustrated in Figures 8 and 9 on page 30 are not exceeded. Air flow may be needed to achieve these temperature values. Continual or sustained operation at case temperatures above these values will degrade MTBF.

The drive meets all specifications over a 41°F to 122°F (5°C to 50°C) drive ambient temperature range with a maximum gradient of 36°F (20°C) per hour when the case temperature limits specified above are not exceeded.

#### b. Non-operating

Non-operating temperature should remain between –40°F to 158°F (–40°C to 70°C) package ambient with a maximum gradient of 36°F (20°C) per hour. This assumes that the drive is packaged in the shipping container designed by Seagate.

### 6.4.2 Relative humidity

The values below assume that no condensation on the drive occurs.

#### a. Operating

5% to 95% relative humidity with a maximum gradient of 10% per hour.

#### b. Non-operating

5% to 95% relative humidity.

### 6.4.3 Effective altitude (sea level reference)

#### a. Operating

–1,000 to +10,000 feet (–305 to +3,048 meters)

#### b. Non-operating

–1,000 to +40,000 feet (–305 to +12,210 meters)

### 6.4.4 Shock and vibration

Shock and vibration limits specified in this document are measured directly on the drive chassis. If the drive is installed in an enclosure to which the stated shock and/or vibration criteria are applied, resonances may occur internally to the enclosure resulting in drive movement in excess of the stated limits. If this situation is apparent, it may be necessary to modify the enclosure to minimize drive movement.

The limits of shock and vibration defined within this document are specified with the drive mounted in a vertical or horizontal position and in accordance with the restrictions of Section 8.4. Orientation of the side nearest the LED may be up or down.

#### 6.4.4.1 Shock

##### a. Operating (normal)

The drive, as installed for normal operation, will operate error free while subjected to intermittent shock not exceeding 2.0 Gs at a maximum duration of 11 msec (half sinewave). Shock may be applied in the X, Y, or Z axis.

##### b. Operating (abnormal)

Equipment as installed for normal operation will not incur physical damage while subjected to intermittent shock not exceeding 10 Gs at a maximum duration of 11 msec (half sinewave). Shock occurring at abnor-

mal levels may promote degraded operational performance during the abnormal shock period. Specified operational performance will continue when normal operating shock levels resume. Shock may be applied in the X, Y, or Z axis. Shock is not to be repeated more than two times per second.

c. Non-operating

The limits of non-operating shock apply to all conditions of handling and transportation. This includes both isolated drives and integrated drives.

The drive subjected to non-repetitive shock not exceeding 75 Gs at a maximum duration of 11 msec (half sinewave) will not exhibit device damage or performance degradation. Shock may be applied in the X, Y, or Z axis.

The drive subjected to non-repetitive shock not exceeding 140 Gs at a maximum of 2 msec (half sinewave) will not exhibit device damage or performance degradation. Shock may be applied in the X, Y, or Z axis.

d. Packaged

Disc drives shipped as loose load (not palletized) general freight will be packaged to withstand drops from heights as defined in the table below. For additional details, refer to Seagate specifications 30190-001 (under 100 lbs/45 kg) or 30191-001 (over 100 lbs/45 kg).

Package size	Packaged/product weight	Drop height
<600 cu in (<9,800 cu cm)	Any	60 in (1,524 mm)
600 to 1,800 cu in (9,800 to 19,700 cu cm)	0 to 20 lb (0 to 9.1 kg)	48 in (1,219 mm)
>1,800 cu in (>19,700 cu cm)	0 to 20 lb (0 to 9.1 kg)	42 in (1,067 mm)
>600 cu in (>9,800 cu cm)	20 to 40 lb (9.1 to 18.1 kg)	36 in (914 mm)

#### 6.4.4.2 Vibration

a. Operating (normal)

The drive as installed for normal operation will operate error free while subjected to continuous vibration not exceeding:

5–350 Hz @ 0.5 G

Vibration may be applied on the X, Y, or Z axis.

b. Operating (abnormal)

Equipment as installed for normal operation will not incur physical damage while subjected to periodic vibration not exceeding:

15 minutes of duration at major resonant frequency

5–350 Hz @ 0.75 G

Vibration occurring at these levels may degrade operating performance during the abnormal vibration period. Specified operating performance will continue when normal operating vibration levels are resumed. This assumes system recovery routines are available. Abnormal vibration may be applied on the X, Y, or Z axis.

c. Non-operating

The limits of non-operating vibration apply to all conditions of handling and transportation. This includes both isolated drives and integrated drives.

The drive will not incur physical damage or degraded performance as a result of continuous vibration not exceeding:

5–22 Hz @ 0.040 in. (1.02 mm) displacement

22–400 Hz @ 2.00 Gs

Vibration may be applied in the X, Y, or Z axis.

#### 6.4.5 Air cleanliness

The drive is designed to operate in a typical office environment with minimal environmental control.



**6.5 Electromagnetic susceptibility**

As a component part, the drive is not required to meet any susceptibility performance requirements. It is the responsibility of the system integrator to perform tests required to ensure that equipment operating in the same system as the drive does not adversely affect the performance of the drive. See paragraph 6.2, “DC power requirements.”

**6.6 Mechanical specifications**

The following nominal dimensions are exclusive of the decorative front panel accessory. See Figure 4 for detailed mounting configuration dimensions for the drive. See Figure 12 for detailed FC-AL SCA connector dimensions.

Height	1.0 in	25.4 mm
Width	4.00 in	101.6 mm
Depth	5.75 in	146.05 mm
Weight	1.3 lb	0.588 kilograms

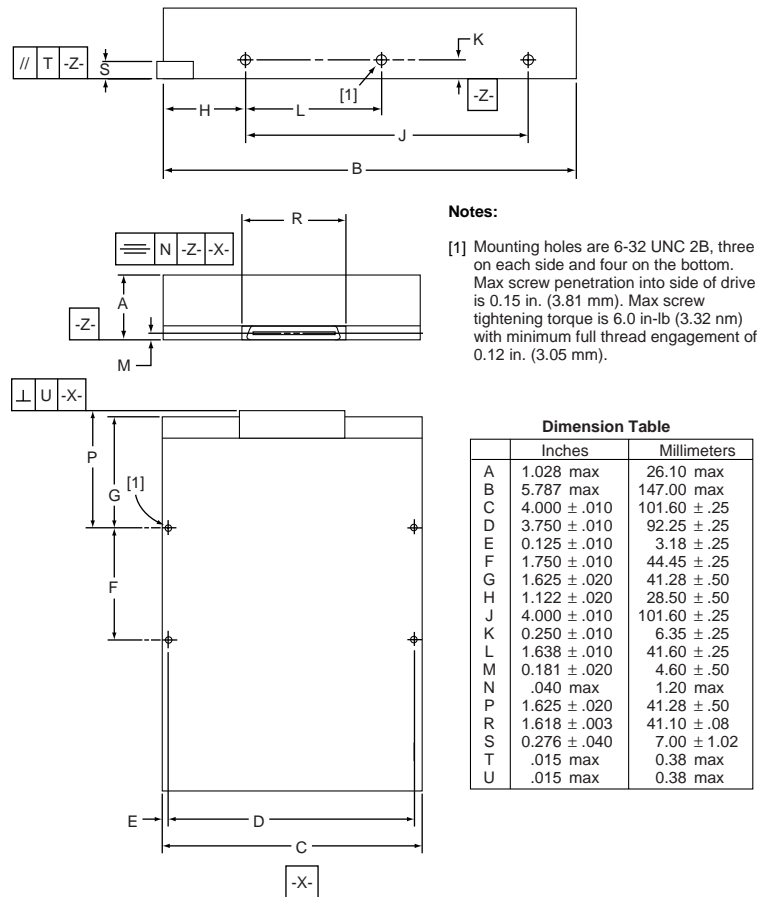

**Figure 4. Mounting configuration dimensions**

**6.7 Acoustics**

Sound power during idle mode is 4.4 bels typical when measured to ISO 7779 specification. There will not be any discrete tones more than 10 dB above the masking noise on typical drives when measured according to Seagate specification 30553-001. There will not be any tones more than 24 dB above the masking noise on any drive.



## 7.0 Defect and error management

The drive, as delivered, complies with this product manual. The read error rates and specified storage capacities are not dependent upon use of defect management routines by the host (initiator).

Defect and error management in the SCSI protocol involves the drive internal defect/error management and FC-AL system error considerations (errors in communications between the initiator and the drive). Tools for use in designing a defect/error management plan are briefly outlined in this section. References to other sections are provided when necessary.

### 7.1 Drive internal defects/errors

During the initial drive format operation at the factory, media defects are identified, tagged as being unusable, and their locations recorded on the drive primary defects list (referred to as the "P" list and also as the ETF defect list). At factory format time, these known defects are also reallocated, that is, reassigned to a new place on the medium and the location listed in the defects reallocation table. The "P" list is not altered after factory formatting. Locations of defects found and reallocated during error recovery procedures after drive shipment are listed in the "G" list (defects growth list). The "P" and "G" lists may be referenced by the initiator using the Read Defect Data command.

Details of the SCSI commands supported by the drive are described in the *Fibre Channel Interface Manual*. Also, more information on the drive Error Recovery philosophy is presented in the *Fibre Channel Interface Manual*.

### 7.2 Drive error recovery procedures

When an error occurs during drive operation, the drive, if programmed to do so, performs error recovery procedures to attempt to recover the data. The error recovery procedures used depend on the options previously set in the Error Recovery Parameters mode page. Error recovery and defect management may involve using several SCSI commands described in the *Fibre Channel Interface Manual*. The drive implements selectable error recovery time limits required in video applications.

The error recovery scheme supported by the drive provides a way to control the total error recovery time for the entire command in addition to controlling the recovery level for a single LBA. The total amount of time spent in error recovery for a command can be limited using the Recovery Time Limit bytes in the Error Recovery mode page. The total amount of time spent in error recovery for a single LBA can be limited using the Read Retry Count or Write Retry Count bytes in the Error Recovery mode page.

The drive firmware error recovery algorithms consists of 12 levels for read recoveries and five levels for write. Each level may consist of multiple steps, where a step is defined as a recovery function involving a single re-read or re-write attempt. The maximum level used by the drive in LBA recovery is determined by the read and write retry counts.

Table 2 equates the read and write retry count with the maximum possible recovery time for read and write recovery of individual LBAs. The times given do not include time taken to perform reallocations. Reallocations are performed when the ARRE bit (for reads) or AWRE bit (for writes) is one, the RC bit is zero, and the recovery time limit for the command has not yet been met. Time needed to perform reallocation is not counted against the recovery time limit.

When the RC bit is one, reallocations are disabled even if the ARRE or AWRE bits are one. The drive will still perform data recovery actions within the limits defined by the Read Retry Count, Write Retry Count, and Recovery Time Limit parameters. However, the drive does not report any unrecovered errors.

**Table 2: Read and write retry count maximum recovery times**

Read retry count <sup>1</sup>	Maximum recovery time per LBA (cumulative, msec)	Write retry count <sup>1</sup>	Maximum recovery time per LBA (cumulative, msec)
0	65.7	0	35.8
1	77.6	1	53.7
2	89.6	2	59.7
3	113.4	3	77.6
4	149.3	4	185.1
5	197.0	5 (default)	226.9
6	244.8		
7	334.3		
8	394.0		
9	441.8		
10	549.2		
11	2,009.2		
12 (default)	4,283.8		

- [1] Setting these retry counts to a value below the default setting could result in degradation of the unrecovered error rate. For example, suppose the read/write recovery page has the RC bit = 0, the read retry count set to 4, and the recovery time limit set to 450. A 4-block read command can take up to 149.3 msec recovery time for each block and a maximum of 450 msec recovery for all four blocks. If either of these limits is reached and a block has not yet been recovered, the command will end with Check Condition status and an unrecoverable read error will be reported.

### 7.3 FC-AL system errors

Information on the reporting of operational errors or faults across the interface is given in the *Fibre Channel Interface Manual*. The FCP Response returns information to the host about numerous kinds of errors or faults. The Receive Diagnostic Results reports the results of diagnostic operations performed by the drive.

Status returned by the drive to the initiator is described in the *Fibre Channel Interface Manual*. Status reporting plays a role in systems error management and its use in that respect is described in sections where the various commands are discussed.

## 8.0 Installation

Cheetah 9LP FC disc drive installation is a plug-and-play process. There are no jumpers, switches, or terminators on the drive. Simply plug the drive into the host's 40-pin Fibre Channel backpanel connector (FC-SCA)—no cables are required. See Section 9.5 for additional information about this connector.

Use the FC-AL interface to select drive ID and all option configurations for devices on the loop.

If multiple devices are on the same FC-AL and physical addresses are used, set the device selection IDs (SEL IDs) on the backpanel so that no two devices have the same selection ID. This is called the hard assigned arbitrated loop physical address (AL\_PA). There are 125 AL\_PAs available (see Table 21 on page 52). If you set the AL\_PA on the backpanel to any value other than 0, the device plugged into the backpanel's SCA connector inherits this AL\_PA. In the event you don't successfully assign unique hard addresses (and therefore have duplicate selection IDs assigned to two or more devices), the FC-AL generates a message indicating this condition. If you set the AL\_PA on the backpanel to a value of 0, the system issues a unique soft-assigned physical address automatically.

Loop initialization is the process used to verify or obtain an address. The loop initialization process is performed when power is applied to the drive, when a device is added or removed from the Fibre Channel loop, or when a device times out attempting to win arbitration.

- Set all option selections in the connector prior to applying power to the drive. If you change options after applying power to the drive, recycle the drive power to activate the new settings.
- It is not necessary to low-level format this drive. The drive is shipped from the factory low-level formatted in 512-byte logical blocks. You need to reformat the drive only if you want to select a different logical block size.

### 8.1 Drive ID/option selection

All drive options are made through the interface connector (J1). Table 18 on page 48 provides the pin descriptions for the 40-pin Fibre Channel single connector (J1).

### 8.2 LED connections

A connector, J6, is provided on the printed circuit board assembly (PCBA) to provide port bypass, drive active, and drive fault LED connections (see Figure 6 on page 28). See Sections 9.5.7, 9.5.8, and 9.5.9 for descriptions of LED functions.

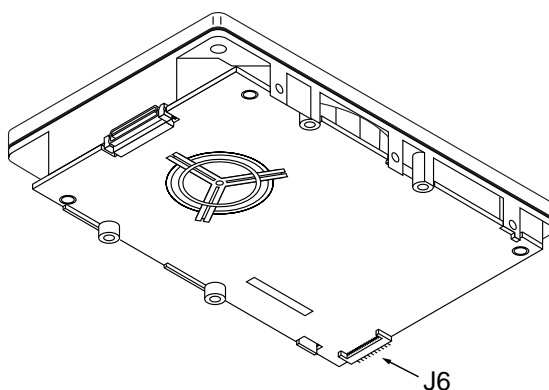
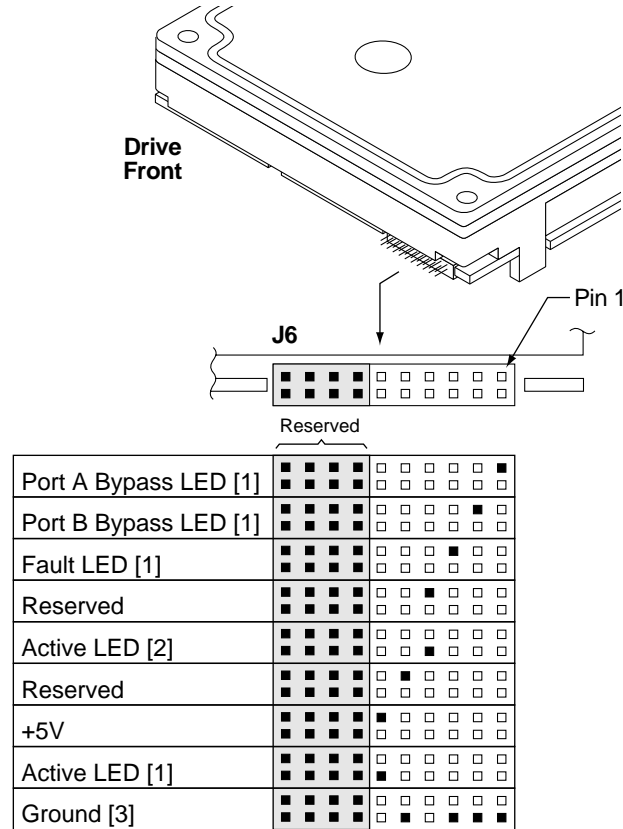

Figure 5. Physical interface



- [1] The drive has a 2.2K ohm resistor in series with this LED driver. Tie the minus side of an external high-efficiency LED (i.e., 2ma) to this pin. Connect the plus side of the LED to +5V.
- [2] An external current-limiting resistor is required when connecting an LED to this pin. The minus side of the resistor/LED combination is connected to this pin. Connect the plus side to +5V.
- [3] Jumper storage location (across pins 2 and 4).

**Figure 6. LED indicator connector**

**8.2.1 J6 connector requirements**

Recommended mating connector part number: Berg receptacle, 6-position, Berg part number 690-006.

**8.3 Drive orientation**

The drive may be mounted in any orientation. All drive performance characterizations, however, have been done with the drive in horizontal (discs level) and vertical (drive on its side) orientations, which are the two preferred mounting orientations.

**8.4 Cooling**

Cabinet cooling must be designed by the customer so that the ambient temperature immediately surrounding the drive will not exceed temperature conditions specified in Section 6.4.1, "Temperature." Specific consideration should be given to make sure adequate air circulation is present around the printed circuit board (PCB) to meet the requirements of Section 6.4.1, "Temperature."

### 8.4.1 Air flow

The rack, cabinet, or drawer environment for the drive must provide cooling of the electronics and head and disc assembly (HDA). You should confirm that adequate cooling is provided using the temperature measurement guidelines described below.

The drive should be oriented, or air flow directed, so that the least amount of air-flow resistance is created while providing air flow to the electronics and HDA. Also, the shortest possible path between the air inlet and exit should be chosen to minimize the travel length of air heated by the drive and other heat sources within the rack, cabinet, or drawer environment.

Possible air-flow patterns are shown in Figure 7. The air-flow patterns are created by one or more fans, either forcing or drawing air as shown in the illustrations. Other air-flow patterns are acceptable as long as the temperature measurement guidelines are met.

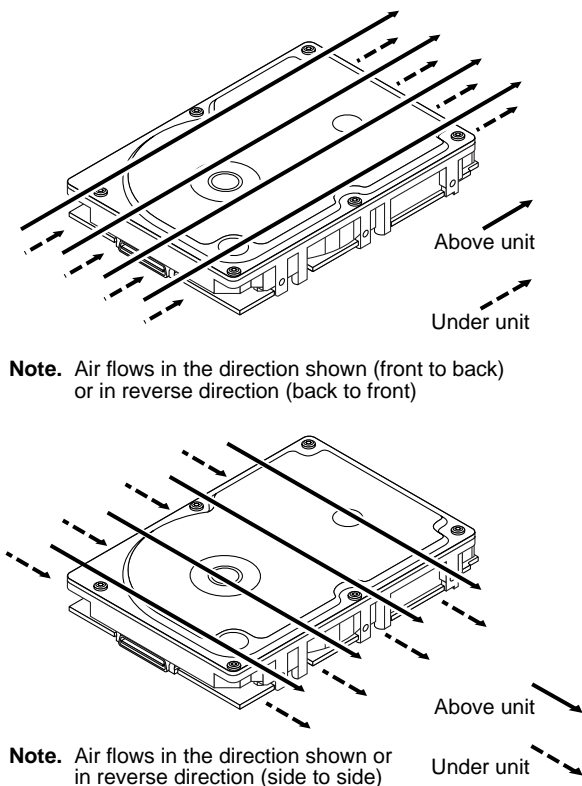

**Figure 7. Air flow**

To confirm that the required cooling for the electronics and HDA is provided, place the drive in its final mechanical configuration, perform random write/read operations and, after the temperatures stabilize, measure the case temperature of the components listed below. Component reference locations are shown in Figure 8. The typical ambient air temperature associated with the list is 25°C and the resulting MTBF is 1,000,000 hours.

Figure 7 shows the air flow pattern used to generate the 1,000,000 hours MTBF temperature guidelines listed below. Local average air velocities were 235 lpm (1.2 m/s) and air temperature was 77°F (25°C) plus a 5°C temperature rise in the test enclosure (30°C ambient local to the drive).

**PCB and HDA temperatures**

<b>Component</b>	<b>Reference</b>	<b>MTBF 1,000,000 hours at 30°C ambient temperature (°C)</b>
HDA	Figure 9	45
Processor	1	45
A/D Demod	2	58
FC Interface	3	62
Motor driver	4	47

To obtain the maximum temperature for each of the reference components listed, add 20°C to the 1,000,000 hour MTBF case temperatures. The maximum allowable HDA case temperature is 60°C (see Figure 9). Operation of the drive at the maximum case temperature is intended for short time periods only. Continuous operation at the elevated temperatures will reduce product reliability.

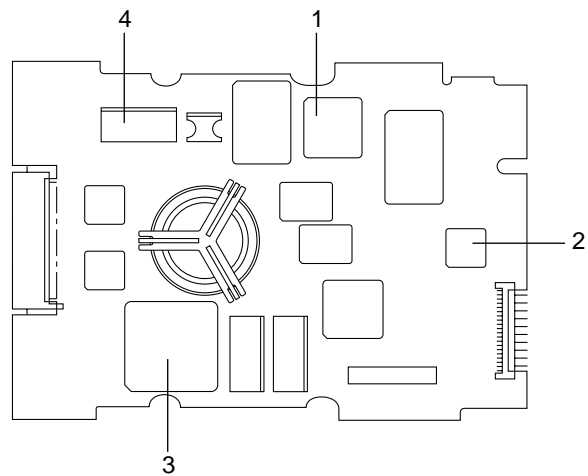

**Figure 8. PCBA temperature measurement locations**

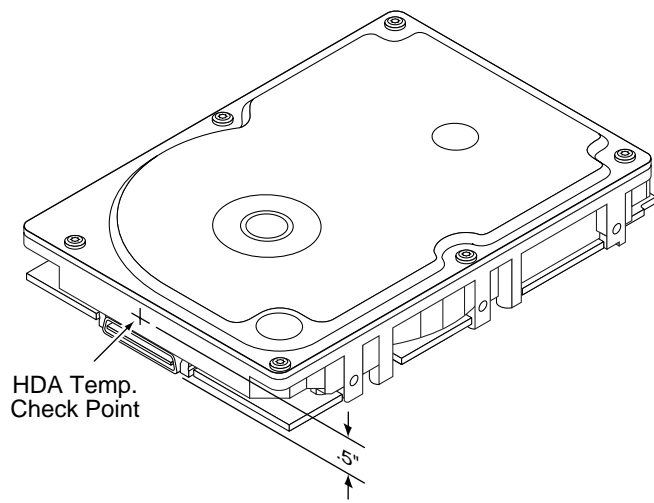

**Figure 9. HDA case temperature measurement location**



### 8.5 Drive mounting

Mount the drive using the bottom or side mounting holes. If you mount the drive using the bottom holes, ensure that you do not physically distort the drive by attempting to mount it on a stiff, non-flat surface.

The allowable mounting surface stiffness is 80 lb/in (14.0 N/mm). The following equation and paragraph define the allowable mounting surface stiffness:

$$K \times X = F \leq 15\text{lb} = 67\text{N}$$

where K is the mounting surface stiffness (units in lb/in or N/mm) and X is the out-of-plane surface distortion (units in inches or millimeters). The out-of-plane distortion (X) is determined by defining a plane with three of the four mounting points fixed and evaluating the out-of-plane deflection of the fourth mounting point when a known force (F) is applied to the fourth point.

### 8.6 Grounding

Signal ground (PCBA) and HDA ground are connected together in the drive and cannot be separated by the user. Maximizing the conductive contact area between HDA ground and system ground may reduce radiated emissions. If you do not want the system chassis to be connected to the HDA/PCBA ground, you must provide a nonconductive (electrically isolating) method of mounting the drive in the host equipment; however, this may increase radiated emissions and is the system designer's responsibility.



## 9.0 Interface requirements

This section partially describes the interface requirements as implemented on ST39102FC drives. Additional information is provided in the *Fibre Channel Interface Manual* (part number 77767496).

### 9.1 FC-AL features

This section lists the Fibre Channel-specific features supported by ST39102FC drives.

#### 9.1.1 Fibre Channel link service frames

Table 3 lists the link services supported by ST39102FC drives.

**Table 3: Link services supported**

Type of frame	Link service
Basic link service frames	Abort Sequence (ABTS)
Basic link service reply frames	Basic_Accept (BA_ACC) Basic_Reject (BA_RJT)
Extended link service frames	N_Port Login (PLOGI) Fabric Login (FLOGI) Logout (LOGO) Process Login (PRLI) Process Logout (PRLO) Read Link Status (RLS) Port Discovery (PDISC) Address Discovery (ADISC) Third-party Process Logout (TRPLO)
Extended link service reply frames	Accept (ACC) Link Service Reject (LS_RJT)

#### 9.1.2 Fibre Channel task management functions

Table 4 lists the Fibre Channel SCSI Fibre Channel Protocol (FC SCSI FCP) task management functions supported.

**Table 4: Fibre Channel SCSI FCP task management functions**

Task name	Supported
Terminate task	No
Clear ACA	Yes
Target reset	Yes
Clear task set	Yes
Abort task set	Yes

#### 9.1.3 Fibre Channel task management responses

Table 5 lists the FC SCSI FCP response codes returned for task management functions supported.

**Table 5: FC SCSI FCP response codes**

Function name	Response code
Function complete	00
Function not supported	04
Function reject	05

9.1.4 Fibre Channel port login

Table 6 identifies the required content of the N\_Port Login (PLOGI) payload from an initiator.

Table 6: N\_Port login (PLOGI) payload

Bytes																	
0-15	03	00	00	00	09	09	BB	BB	CF	XX	FS	FS	XX	XX	XX	XX	Common
16-31	XX	XX	XX	XX	PN	PN	PN	PN	PN	PN	PN	PN	NN	NN	NN	NN	
32-35	NN	NN	NN	NN													
36-47					XX	XX	XX	XX	XX	XX	XX	XX	XX	XX	XX	XX	Class 1
48-51	XX	XX	XX	XX													
52-63					XX	XX	XX	XX	XX	XX	XX	XX	XX	XX	XX	XX	Class 2
64-67	XX	XX	XX	XX													
68-79					SO	SO	IC	IC	XX	XX	FS	FS	XX	CS	XX	XX	Class 3
80-83	OS	OS	XX	XX													
84-95					XX	XX	XX	XX	XX	XX	XX	XX	XX	XX	XX	XX	Reserved
96-99	XX	XX	XX	XX													
100-111					XX	XX	XX	XX	XX	XX	XX	XX	XX	XX	XX	XX	Vendor
112-115	XX	XX	XX	XX													Version

- X Indicates a four-bit (hex) field is not checked.
- x Indicates a single bit is not checked.
- BB BB-Credit. This field is not checked. The FC-AL drive uses BB-Credit of zero (0).
- CF Common features. This binary field selects the common features requested by the initiator login.
  - MSB Continuously increasing offset Must = 1
  - Random relative offset Not checked. Port Login Accept will return a 0—not supported.
  - Valid version level x
  - N\_Port/F\_Port Must = 0, N\_Port
  - Alternate credit model Must = 1
  - Other bits reserved xxx XX
- FS Receive buffer field size. The FS field in the common and Class 3 parameters is checked for the range 128 < FS < 2,112 and a multiple of four bytes. For multiple frame sequences, all frames but the last frame of the sequence must be this size. Only the receive buffer field size in the Class 3 parameters is used.
- PN Port name (initiator's)—saved with the login parameters. If a change of the port name/AL\_PA address association is detected during a Port DIScovery, and implicit logout occurs and the initiator returns a LS\_RJT.
- NN Node name. The node name is not checked or saved by the drive.
- SO Service options Class 3 only.
  - MSB Class valid Must = 1
  - Intermix x
  - Stacked connection req. xx
  - Sequential delivery x
  - Other bits reserved xxx XX
- IC Initiator control
  - MSB XID reassign xx
  - Proc Assc 10 or 11 causes the login to be rejected. Other values are accepted.
  - Other bits XXX
- CS Concurrent sequences Must be a value greater than 0.
- OS Open sequences per exchange Must be a value greater than 0.



### 9.1.8 Fibre Channel fabric login

Table 10 lists the fabric login payload from the drive.

**Table 10: Fabric Login (FLOGI) payload**

Bytes																	
0-15	04	00	00	00	09	09	00	00	08	00	08	40	00	00	00	00	Common
16-31	00	00	02	F4	20	PP	00	20	37	UI	UI	UI	02	00	00	20	
32-35	37	UI	UI	UI													
36-47					00	00	00	00	00	00	00	00	00	00	00	00	Class 1
48-51	00	00	00	00													
52-63					00	00	00	00	00	00	00	00	00	00	00	00	Class 2
64-67	00	00	00	00													
68-79					80	00	00	00	00	00	08	40	00	00	00	00	Class 3
80-83	00	00	00	00													
84-95					00	00	00	00	00	00	00	00	00	00	00	00	Reserved
96-99	00	00	00	00													
100-111					00	00	00	00	00	00	00	00	00	00	00	00	Vendor -
112-115	00	00	00	00													Version

UI Unique identifier. This 24-bit field is uniquely assigned to the drive. This same UI appears in the Port Name and Node Name fields.

PP Port identifier field.

01 FLOGI received on Port A.

02 FLOGI received on Port B.

### 9.1.9 Fibre Channel fabric accept login

Table 10 lists the required content of the Fabric Login Accept (ACC) payload from the fabric.

**Table 11: Fabric Login Accept (ACC) payload**

Bytes																	
0-15	02	00	00	00	09	09	BB	BB	CF	XX	FS	FS	R_	A_	T0	V_	Common
16-31	E_	D_	T0	V_	PN	PN	PN	PN	PN	PN	PN	PN	NN	NN	NN	NN	
32-35	NN	NN	NN	NN													
36-47					XX	XX	XX	XX	XX	XX	XX	XX	XX	XX	XX	XX	Class 1
48-51	XX	XX	XX	XX													
52-63					XX	XX	XX	XX	XX	XX	XX	XX	XX	XX	XX	XX	Class 2
64-67	XX	XX	XX	XX													
68-79					SO	SO	xx	xx	XX	XX	FS	FS	XX	xx	XX	XX	Class 3
80-83	OS	OS	XX	XX													
84-95					XX	XX	XX	XX	XX	XX	XX	XX	XX	XX	XX	XX	Reserved
96-99	XX	XX	XX	XX													
100-111					XX	XX	XX	XX	XX	XX	XX	XX	XX	XX	XX	XX	Vendor -
112-115	XX	XX	XX	XX													Version

X Indicates a four-bit (hex) field is not checked.

x Indicates a single bit is not checked.

BB BB-Credit. This field is not checked. The FC-AL drive uses BB-Credit of zero (0).

CF Common features. This binary field selects the common features requested by the fabric login.

MSB	Continuously increasing offset	x
	Random relative offset	x
	Valid version level	x
	N_Port/F_Port	Must = 1, F_Port
	Alternate credit model	Must = 1
	Other bits reserved	xxx XX

FS Receive buffer field size. The FS field in the common and Class 3 parameters is checked for the range 128 < FS < 2,112 and a multiple of four bytes. The receive buffer field size in the Class 3 parameters is used. The drive uses the lower FS of Fabric Login Accept or N\_Port Login when sending frames to an initiator.

PN Port Name. The fabric port name is saved with the login parameters. If a change of the port name is detected during a FAN, an implicit logout occurs and a LS\_RJT is returned to the FAB.

NN Node Name. The drive does not check or save the node name.

SO Service Options—Class 3 only.

MSB	Class valid	Must = 1
	Intermix	x
	Stacked connection req.	xx
	Sequential delivery	Must = 1
	Other bits reserved	xxx XX

### 9.1.10 Fibre Channel Arbitrated Loop options

Table 12 lists the FC-AL options supported by Cheetah 9LP FC drives.

**Table 12: FC-AL options supported**

Option	Supported
OPEN Half Duplex	Accepted from another device.
OPEN Full Duplex	Sent to open another device. Accepted from another device.
Private Loop	Yes
Public Loop	Yes
Old Port State	No
Loop Position	Yes
Loop Position Report	Yes

## 9.2 Dual port support

ST39102FC drives have two independent FC-AL ports. These ports may be connected on independent loops or on the same loop. Port A and Port B may be connected in any order or combination.

- If both ports are connected on independent loops and hard addressing is used, the drive interface address is selected through the interface connector, both ports will seek the same loop address. If no conflict, both ports will have the same loop address.
- If both ports are connected in the same loop and hard addressing is used, at least one port will attempt taking a soft address to prevent an address conflict.

**Note.** When a ST39102FC drive is connected in loops with previous Seagate FC drive products:

Barracuda 4LP FC (ST32171FC, ST34371FC, and ST34571FC)  
 Barracuda 9FC (ST19171FC)  
 Cheetah 4LP FC (ST34501FC)  
 Cheetah 9FC (ST19101FC)

the connection of Port A and B for these products must follow the requirements in their product manuals.

Subject to buffer availability, the Cheetah 9LP FC drives support:

- Concurrent port transfers—The drive supports receiving transfers on both ports at the same time when the ports are on independent loops.



### 9.3 SCSI commands supported

Table 13 lists the SCSI commands that ST39102FC drives support.

**Table 13: Supported commands**

Command code	Supported	Command name
00h	Y	Test unit ready
01h	Y	Rezero unit
03h	Y	Request sense
	Y	Extended sense
	Y	Field pointer bytes
	Y	Actual retry count bytes
04h	Y	Format unit [1]
07h	Y	Reassign blocks
08h	Y	Read
0Ah	Y	Write
0Bh	Y	Seek
12h	Y	Inquiry
	Y	Vital product data page
	Y	Unit serial number page
	Y	Implemented operating def. page
	Y	Firmware numbers page
	Y	Date code page
	Y	Jumper settings page
15h	Y	Mode select (same pages as Mode Sense command shown below) [3]
16h	Y	Reserve
	N	3rd party reserved
	N	Extent reservation
17h	Y	Release
18h	N	Copy
1Ah	Y	Mode sense
	Y	Unit attention page (00h)
	Y	Error recovery page (01h)
	Y	Disconnect/reconnect control (page 02h)
	Y	Format page (03h)
	Y	Rigid disc drive geometry page (04h)
	Y	Verify error recovery page (07h)
	Y	Caching parameters page (08h)
	Y	Control mode page (0Ah)
	Y	Power control page (1Ah)
	Y	Information exceptions control page (1Ch)
1Bh	Y	Start unit/stop unit
1Ch	Y	Receive diagnostic results
	Y	Supported diagnostics pages
	Y	Translate page
	Y	Enclosure services page

Table 13: Supported commands (*continued*)

Command code	Supported ( <i>continued</i> )	Command name
1Dh	Y	Send diagnostics page
	Y	Supported diagnostics pages
	Y	Translate page
25h	Y	Read capacity
28h	Y	Read extended
	Y	Disable page out
	Y	Force unit access
	N	Relative address
2Ah	Y	Write extended
	Y	Disable page out
	Y	Force unit access
	N	Relative address
2Bh	Y	Seek extended
2Eh	Y	Write and verify
	Y	Disable page out
	Y	Byte check
	N	Relative address
2Fh	Y	Verify
	Y	Disable page out
	Y	Byte check
	N	Relative address
30h	N	Search data high
31h	N	Search data equal
32h	N	Search data low
33h	N	Set limits
34h	N	Prefetch
35h	Y	Synchronize cache
36h	N	Lock-unlock-cache
37h	Y	Read defect data
39h	N	Compare
3Ah	N	Copy and verify
3Bh	Y	Write buffer
	Y	Write combined header and data mode (0)
	Y	Write data mode (2)
	N	Download microcode mode (4)
	Y	Download microcode and save modes (5)
	N	Download microcode with offsets mode (6)
	Y	Download microcode with offsets and save mode (7)
	Y	Firmware download option [2]
3Ch	Y	Read buffer
	Y	Read combined header and data mode (0)
	Y	Read data mode (2)
	Y	Read descriptor mode (3)

Table 13: Supported commands (*continued*)

Command code	Supported ( <i>continued</i> )	Command name
3Eh	Y	Read long
3Fh	Y	Write long
40h	N	Change definition
41h	Y	Write same
	N	PBdata
	N	LBdata
42-4Bh	N	Not used
4Ch	Y	Log Select
4Dh	Y	Log Sense
4E-4Fh	N	Not used
50h	N	XD write
51h	N	XP write
52h	N	XD read
53-54h	N	Not used
55h	Y	Mode Select (10) [3]
56h	Y	Reserved (10)
	Y	3rd party reserve
	N	Extent reservation
57h	Y	Released (10)
58-59h	N	Not used
5Ah	Y	Mode Sense (10) [3]
5B-5Dh	N	Not used
5E	Y	Persistent reserve in
5F	Y	Persistent reserve out
60-7Fh	N	Not used
80h	N	XD write extended
81h	N	Rebuild
82h	N	Regenerate
83-8Fh	N	Not used
C0-DFh	N	Not used
EO-FFh	N	Not used

- [1] Cheetah 9LP FC drives can format to any multiple of four bytes per logical block in the range 512 to 4,096 bytes.
- [2] **Warning.** Power loss during flash programming can result in firmware corruption. This usually makes the drive inoperable.
- [3] Reference Mode Sense command 1Ah for mode pages supported.

### 9.3.1 Inquiry data

Table 14 lists the Inquiry command data that the drive should return to the initiator per the format given in the *Fibre Channel Interface Manual*.

**Table 14: Cheetah 9LP FC inquiry data**

Bytes	Data (hex)																
0-15	00	00	**	22	8B	00	PP	0A	53	45	41	47	41	54	45	20	Vendor ID
16-31	[53	54	33	39	31	30	32	46	43]	20	20	20	20	20	20	20	Product ID
32-47	R#	R#	R#	R#	S#	S#	S#	S#	S#	S#	S#	S#	00	00	00	00	
48-63	00	00	00	00	00	00	00	00	00	00	00	00	00	00	00	00	
64-79	00	00	00	00	00	00	00	00	00	00	00	00	00	00	00	00	
80-95	00	00	00	00	00	00	00	00	00	00	00	00	00	00	00	00	
96-111	00	43	6F	70	79	72	69	67	68	74	20	28	63	29	20	31*	*Copyright
112-127	39*	39*	38*	20	53	65	61	67	61	74	65	20	41	6C	6C	20	notice
128-143	72	69	67	68	74	73	20	72	65	73	65	72	76	65	64	20	

\* Copyright year (changes with actual year).

\*\* 02 = SCSI-2 implemented with some SCSI-3 features (default).

PP 50 = Inquiry data for an Inquiry command received on Port A.

70 = Inquiry data for an Inquiry command received on Port B.

R# Four ASCII digits representing the last four digits of the product firmware release number.

S# Eight ASCII digits representing the eight digits of the product serial number.

[ ] Bytes 16 through 24 reflect drive model.

### 9.3.2 Mode Sense data

The Mode Sense command provides a way for the drive to report its operating parameters to the initiator. The drive maintains four sets of mode parameters:

#### 1. Default values

Default values are hard-coded in the drive firmware stored in flash E-PROM (nonvolatile memory) on the drive's PCB. These default values can be changed only by downloading a complete set of new firmware into the flash E-PROM. An initiator can request and receive from the drive a list of default values and use those in a Mode Select command to set up new current and saved values, where the values are changeable.

#### 2. Saved values

Saved values are stored on the drive's media using a Mode Select command. Only parameter values that are allowed to be changed can be changed by this method. Parameters in the saved values list that are not changeable by the Mode Select command get their values from default values storage.

When power is applied to the drive, it takes saved values from the media and stores them as current values in volatile memory. It is not possible to change the current values (or the saved values) with a Mode Select command before the drive achieves operating speed and is "ready." An attempt to do so results in a "Check Condition" status.

On drives requiring unique saved values, the required unique saved values are stored into the saved values storage location on the media prior to shipping the drive. Some drives may have unique firmware with unique default values also.

On standard OEM drives, the saved values are taken from the default values list and stored into the saved values storage location on the media prior to shipping.

#### 3. Current values

Current values are volatile values being used by the drive to control its operation. A Mode Select command can be used to change the values identified as changeable values. Originally, current values are installed from saved or default values after a power on reset, hard reset, or Bus Device Reset message.

#### 4. Changeable values

Changeable values form a bit mask, stored in nonvolatile memory, that dictates which of the current values and saved values can be changed by a Mode Select command. A one (1) indicates the value can be changed. A zero (0) indicates the value is not changeable. For example, in Table 15, refer to Mode page 81, in the row entitled "CHG." These are hex numbers representing the changeable values for Mode page 81. Note in columns 5 and 6 (bytes 04 and 05), there is 00h which indicates that in bytes 04 and 05 none of the bits are changeable. Note also that bytes 06, 07, 09, 10, and 11 are not changeable, because those fields are all zeros. In byte 02, hex value FF equates to the binary pattern 11111111. If there is a zero in any bit position in the field, it means that bit is not changeable. Since all of the bits in byte 02 are ones, all of these bits are changeable.

The changeable values list can only be changed by downloading new firmware into the flash E-PROM.

**Note.** Because there are often several different versions of drive control firmware in the total population of drives in the field, the Mode Sense values given in the following tables may not exactly match those of some drives.

The following tables list the values of the data bytes returned by the drive in response to the Mode Sense command pages for SCSI implementation (see the *Fibre Channel Interface Manual*).

Definitions:

DEF = Default value. Standard OEM drives are shipped configured this way.

CHG = Changeable bits; indicates if default value is changeable.



#### 9.4 Miscellaneous operating features and conditions

Table 16 lists various features and conditions. A “Y” in the support column indicates the feature or condition is supported. An “N” in the support column indicates the feature or condition is not supported.

**Table 16: Miscellaneous features**

Supported	Feature or condition
Y	FC-AL selective reset
Y	Automatic contingent allegiance
N	Asynchronous event notification
N	Synchronized (locked) spindle operation
Y	Segmented caching
N	Zero latency read
Y	Queue tagging (up to 128 queue tags supported)
Y	Deferred error handling
Y	Parameter rounding (controlled by Round bit in Mode Select page 0)
Y	Reporting actual retry count in Extended Sense bytes 15, 16, and 17
N	Adaptive caching
Y	SMP = 1 in Mode Select command needed to save RPL and rotational offset bytes

**Table 17: Miscellaneous status**

Supported	Status
Y	Good
Y	Check condition
Y	Condition met/good
Y	Busy
Y	Intermediate/good
Y	Intermediate/condition met/good
Y	Reservation conflict
Y	Task set full
Y	ACA active
Y	ACA active, faulted initiator

## 9.5 FC-AL physical interface

Figure 10 shows the location of the J1 Fibre Channel single connection attachment (FC-SCA) and the J6 connector. Figure 12 provides the dimensions of the FC-SCA. Figure 13 provides the dimensions of the J6 connector.

Details of the physical, electrical, and logical characteristics are provided within this section. The operational aspects of Seagate's Fibre Channel drives are provided in the *Fibre Channel Interface Manual*.

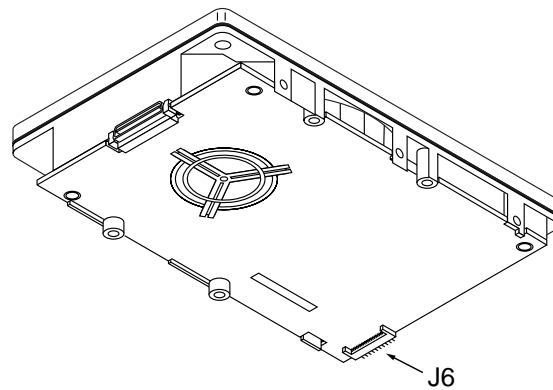

**Figure 10.** Physical interface

### 9.5.1 Physical characteristics

This section defines physical interface connector.

#### 9.5.1.1 Physical description

Fibre Channel drives may be connected in a loop together or with other compatible FC-AL devices. A maximum of 127 devices may have addresses; however, one of the addresses is reserved for a fabric port switch device. This means 126 addresses are available for FC-AL devices. More FC-AL compatible devices may physically reside on the loop, but they will not be functional because they would not be able to obtain valid addresses.

Port bypass circuits (PBCs) allow devices to be inserted into unpopulated locations or removed from the loop with loop operation recovery after a brief interruption. These PBCs are located external to the FC-AL device. Figure 11 shows the relationship between the PBC and FC-AL device.

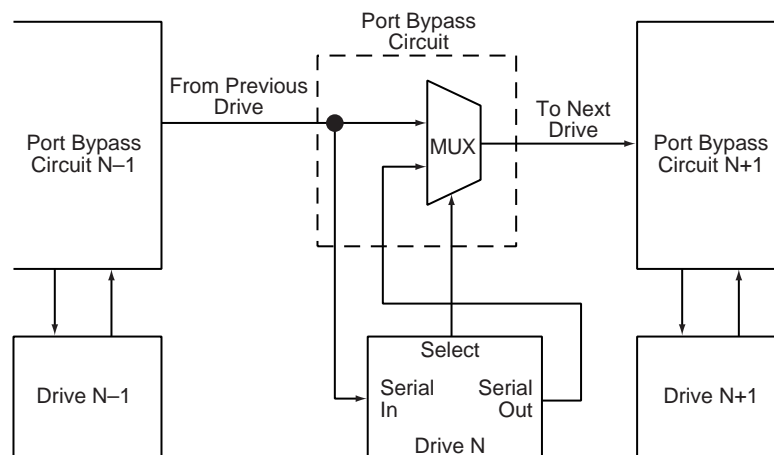

**Figure 11.** Port bypass circuit physical interconnect



9.5.2 Connector requirements

Recommended mating SCA part number:

Part description	Positions	Part number	Features
AMP Vertical (SCA sequence)	40	787317-1	With polarization
Berg	40	71781	With polarization
Methode	40	512-220-91-101N	With polarization
Molex	40	717431040	With polarization

The FC-AL SCA device connector is illustrated in Figure 12. The J6 connector is illustrated in Figure 13.

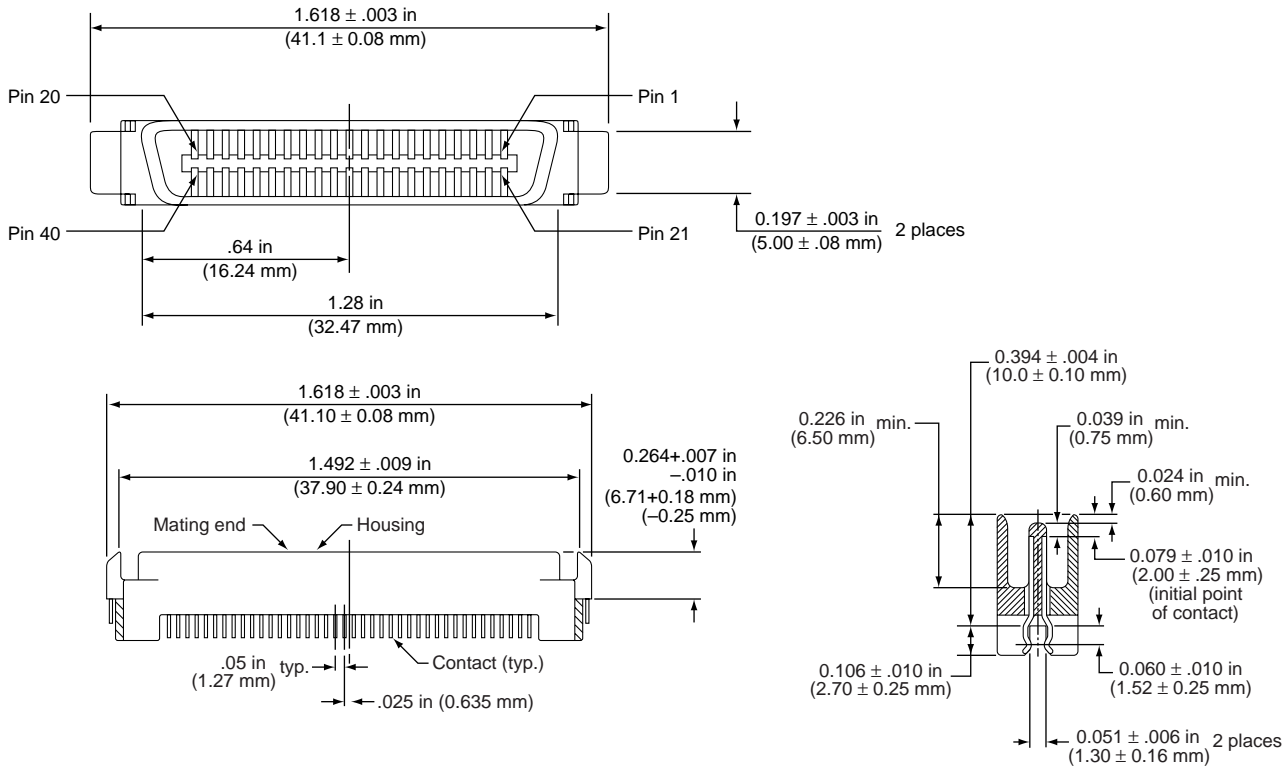

Figure 12. FC-AL SCA device connector dimensions

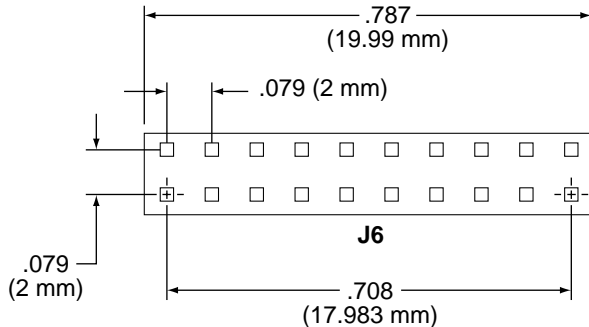

Figure 13. J6 connector dimensions

### 9.5.3 Electrical description

Fibre Channel drives use the FC-SCA connector for:

- DC power
- FC-AL interface
- Drive select (device identification)
- Option selection
- Enclosure Services interface

This 40-pin connector is designed to plug directly into a backpanel. External cables are not required.

### 9.5.4 Pin descriptions

This section provides a pin-out of the FC-SCA and a description of the functions provided by the pins.

**Table 18: FC-SCA pin descriptions**

Pin	Signal name	Signal type	Pin	Signal name	Signal type
1*	-EN bypass port A	TTL output	21	12 Volts charge	
2*	12 Volts		22	Ground	
3*	12 Volts		23	Ground	
4*	12 Volts		24*	+Port A_in	Diff. PECL input pair
5*	-Parallel ESI		25*	-Port A_in	
6*	Ground <sup>[1]</sup>		26	Ground	
7*	Active LED out	Open collector out	27*	+Port B_in	Diff. PECL input pair
8*	Reserved		28*	-Port B_in	
9*	Start_1	TTL input	29	Ground	
10*	Start_2	TTL input	30*	+Port A_out	Diff PECL output pair
11*	-EN bypass port B	TTL output	31*	-Port A_out	
12*	SEL_6	TTL input/output	32	Ground	
13*	SEL_5	TTL input/output	33*	+Port B_out	Diff PECL output pair
14*	SEL_4	TTL input	34*	-Port B_out	
15*	SEL_3	TTL input/output	35	Ground	
16*	Fault LED out	Open collector out	36	SEL_2	TTL input/output
17*	Reserved NC		37	SEL_1	TTL input/output
18*	Reserved NC		38	SEL_0	TTL input/output
19*	5 Volts		39	Reserved NC	
20*	5 Volts		40	5 Volts charge	

\*Short pins in mating backpanel connector.

[1] This pin may be connected to external logic to detect the presence of the drive. The drive connects this pin to the common ground.

**9.5.5 FC-AL transmitters and receivers**

A typical FC-AL differential copper transmitter and receiver pair is shown in Figure 14. The receiver is required to provide the AC coupling to eliminate ground shift noise.

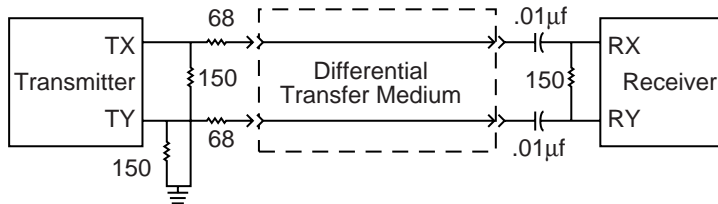

**Figure 14. FC-AL transmitters and receivers**

**9.5.6 Power**

Power is supplied through the FC-SCA with support for +5 volts and +12 volts. All of the voltage pins in the drive connector are the same length.

Four 12 volt pins provide +12 volt power to the drive. The current return for the +12 volt power supply is through the common ground pins. The supply current and return current must be distributed as evenly as possible among the pins. The maximum current typically occurs while the drive motor is starting.

Three 5 volt pins provide logic power to the drive. The current return for the +5 volt power supply is through the common ground pins. Distribute supply and return current as evenly as possible among the voltage and ground pins.

The mating connector pins use shorter contacts to achieve power surge reductions and to aid in “hot plugging” the drives. There are longer voltage contacts in the connector to enable the drive filter capacitors to charge. Current to the drive through the long charge pins is limited by the system in which the drive operates. Three of the +12 volt pins are shorter to allow capacitive pre-charging through the longer +12 volt charge pin. Two of the +5 volt pins are shorter to allow capacitive precharging through the longer +5 volt charge pin.

**9.5.7 Fault LED Out**

The Fault LED Out signal is driven by the drive when:

- the drive detects failure of both ports
- the drive detects an internal failure
- the drive receives the appropriate fault LED command from the host

The Fault LED Out signal is designed to pull down the cathode of an LED. The anode is attached to the proper +5 volt supply through an appropriate current-limiting resistor. The LED and the current-limiting resistor are external to the drive.

**9.5.8 Active LED Out**

The Active LED Out signal is driven by the drive as indicated in Table 19.

**Table 19: Active LED Out conditions**

Normal command activity	LED status
Spun down and no activity	Slow blink (20% on and 80% off a 2 sec cycle)
Spun down and activity (command executing)	On
Spun up and no activity	On
Spun up and activity (command executing)	Off
Spinning up or down	Blinks steadily (50% on and 50% off)
Format in progress, each cylinder change	Toggles on/off

The Active LED Out signal is designed to pull down the cathode of an LED. The anode is attached to the proper +5 volt supply through an appropriate current limiting resistor. The LED and the current limiting resistor are external to the drive.

### 9.5.9 Enable port bypass signals

The – Enable Bypass Port A (– EN BYP Port A ) and – Enable Bypass Port B (– EN BYP Port B) signals control the port bypass circuits (PBC) located external to the disc drive. The PBC allows a loop to remain functional in the event of a drive failure or removal. When these signals are active, low, the PBC bypasses the drive on the associated port. When an Enable Bypass signal is active, the corresponding Port Bypass LED signal in connector J1 is driven low by the disc drive. A pull down resistor, 1K, located with the PBC should be used to insure the bypass is enabled if the disc drive is not installed.

The Enable Bypass signal is active under failing conditions within the drive, on detection of the Loop Port Bypass primitive sequence, or on removal of the drive. In the bypass state the drive continues to receive on the inbound fibre. Enable Bypass may be deactivated by detection of a Loop Port Enable primitive sequence if the drive has completed self-test and a hardware failure is not present.

Failure modes detected by the disc drive that will enable bypass include:

- Transmitter/receiver wrap test failure
- Loss of receive clock
- Loss of transmission clock
- Drive interface hardware error

### 9.5.10 Motor start controls

The drive's motor is started according to the Start\_1 and Start\_2 signals described in Table 20. The state of these signals can be wired into the backplane socket or driven by logic on the backplane.

**Table 20: Motor start control signals**

Case	Start_2	Start_1	Motor spin function
1	Low	Low	Motor spins up at DC power on.
2	High	Low	Motor spins up only when SCSI Start command is received.
3	Low	High	Motor spins up after a delay of 12 seconds times the modulo 8 value of the numeric SEL ID of the drive from DC power on.
4	High	High	The drive will not spin up.

### 9.5.11 SEL\_6 through SEL\_0 ID lines

The SEL\_6 through SEL\_0 ID lines determine drive address, and, optionally, for an Enclosure Services Interface. When the Parallel ESI line is high, the enclosure backpanel must provide address information on the SEL line. Refer to table 21 for a mapping of SEL to FC-AL physical addresses (AL\_PA). You can think of the SEL lines as the equivalent of a backpanel logic plug. The drives does not provide pull up resistors on these lines. The backpanel is required to provide high and low inputs to the SEL\_ID lines per the specifications in table 22 on page 53.

**Note.** Table 21 gives AL\_PA values for each SEL value. The first entry in the table is SEL\_ID 00. The last entry is SEL\_ID 7D. SEL\_ID 7E is AL\_PA 00 which is not valid for an NL\_Port, so is not included in the table. Also, SEL\_ID 7Fh does map to a valid AL\_PA; however, this value signals the drive that physical addresses are not being assigned using the SEL lines and that a “soft” address will be determined by FC-AL loop initialization.

When the Parallel ESI line is low, the enclosure backpanel logic switches to ESI mode if supported. There are two modes of ESI, seven bits of enclosure status and a bidirectional mode. ESI support and the mode are determined by the drive using a discovery process. Refer to the *Fibre Channel Interface Manual* for a description of ESI operation.

### 9.5.11.1 Parallel Enclosure Services Interface (ESI)

The parallel ESI line is an output from the drive. This line provides the enclosure with an indication of the present function of the SEL lines. A high level, the default state, indicates the drive requires address information on the SEL lines. A low level indicates the drive is attempting an ESI transfer. The enclosure may not support ESI on any or all drive locations. It may only support the address function. Support of ESI is discovered by the drive. Refer to the *Fibre Channel Interface Manual* for a description of ESI operations.

Table 21: Arbitrated loop physical address (AL\_PA) values

AL_PA (hex)	SEL ID (hex)	Setting (dec)
EF	00	00
E8	01	01
E4	02	02
E2	03	03
E1	04	04
E0	05	05
DC	06	06
DA	07	07
D9	08	08
D6	09	09
D5	0A	10
D4	0B	11
D3	0C	12
D2	0D	13
D1	0E	14
CE	0F	15
CD	10	16
CC	11	17
CB	12	18
CA	13	19
C9	14	20
C7	15	21
C6	16	22
C5	17	23
C3	18	24
BC	19	25
BA	1A	26
B9	1B	27
B6	1C	28
B5	1D	29
B4	1E	30
B3	1F	31
B2	20	32
B1	21	33
AE	22	34
AD	23	35
AC	24	36
AB	25	37
AA	26	38
A9	27	39
A7	28	40
A6	29	41
A5	2A	42

AL_PA (hex)	SEL ID (hex)	Setting (dec)
A3	2B	43
9F	2C	44
9E	2D	45
9D	2E	46
9B	2F	47
98	30	48
97	31	49
90	32	50
8F	33	51
88	34	52
84	35	53
82	36	54
81	37	55
80	38	56
7C	39	57
7A	3A	58
79	3B	59
76	3C	60
75	3D	61
74	3E	62
73	3F	63
72	40	64
71	41	65
6E	42	66
6D	43	67
6C	44	68
6B	45	69
6A	46	70
69	47	71
67	48	72
66	49	73
65	4A	74
63	4B	75
5C	4C	76
5A	4D	77
59	4E	78
56	4F	79
55	50	80
54	51	81
53	52	82
52	53	83
51	54	84
4E	55	85

AL_PA (hex)	SEL ID (hex)	Setting (dec)
4D	56	86
4C	57	87
4B	58	88
4A	59	89
49	5A	90
47	5B	91
46	5C	92
45	5D	93
43	5E	94
3c	5F	95
3A	60	96
39	61	97
36	62	98
35	63	99
34	64	100
33	65	101
32	66	102
31	67	103
2E	68	104
2D	69	105
2C	6A	106
2B	6B	107
2A	6C	108
29	6D	109
27	6E	110
26	6F	111
25	70	112
23	71	113
1F	72	114
1E	73	115
1D	74	116
1B	75	117
18	76	118
17	77	119
10	78	120
0F	79	121
08	7A	122
04	7B	123
02	7C	124
01	7D	125

## 9.6 Signal characteristics

This section describes the electrical signal characteristics of the drive's input and output signals. See Table 18 on page 48 for signal type and signal name information.

### 9.6.1 TTL input characteristics

Table 22 provides the TTL characteristics.

**Table 22: TTL characteristics**

State	Voltage	Current
Input high	$1.9 < V_{IH} < 5.5V$	$I_{IH} = \pm 500nA$ max.
Input low	$-0.5V < V_{IL} < 0.9V$	$I_{OL} = \pm 500nA$ max.
Output high (-EN Bypass A, B)	$2.4 < V_{OH} < 5.25V$	$I_{OH} < -3mA$
Output low (-EN Bypass A, B)	$V_{OL} < 0.5V$	$I_{OL} < 3mA$
Output high (-Parallel ESI)	$2.4 < V_{OH} < 0.9 V_{CC}$ $V_{OH} > 0.9V_{CC}$	$I_{OH} < -2.4mA$ $I_{OH} < -500\mu A$
Output low (-Parallel ESI)	$0 < V_{OL} < .45V$	$I_{OL} < 2.4mA$
Output high (all other outputs)	$2.4 < V_{OH} < 0.9 V_{CC}$ $V_{OH} > 0.9V_{CC}$	$I_{OH} < -1.6mA$ $I_{OH} < -500\mu A$
Output low (all other outputs)	$0 < V_{OL} < .45V$	$I_{OL} < 1.6mA$

### 9.6.2 LED driver signals

Fault and Active LED signals are located in the FC-SCA connector (J1) and through the indicator connector (J6). See Table 23 for the output characteristics of the LED drive signals.

**Table 23: LED drive signal**

State	Current drive available	Output voltage
LED off, high	$0 < I_{OH} < 100\mu A$	
LED on, low	$I_{OL} < -30 mA$	$0 < V_{OL} < 0.8V$

### 9.6.3 Differential PECL output

The serial PECL output signal voltage characteristics are provided in Table 24. The outputs are not AC coupled in order to deliver maximum signal without rise and fall time degradation. You must AC couple the receiver to isolate potentially different DC characteristics of the outputs and the receiver.

**Table 24: Differential PECL output characteristics**

Description	Parameter	Notes
Serial output voltage swing	$300 < V_{out} < 650 mV$	Centered at 1.32V

Figure 15 provides the data output valid eye diagram relative to the bit cell time.

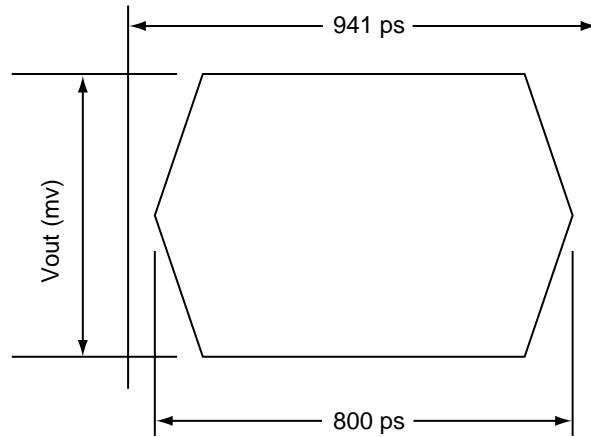

Figure 15. Transmit eye diagram

### 9.6.4 Differential PECL input

The serial PECL input signal voltage characteristics are provided in Table 25.

Table 25: Differential PECL input characteristics

Description	Parameter	Notes
Serial input voltage swing	$200 < V_{in} < 1.300 \text{ mV}$	AC coupled

Figure 16 provides the data valid eye diagram for typical and minimum requirements to recover data at the specified interface error rate. The inputs are AC coupled on the drive.

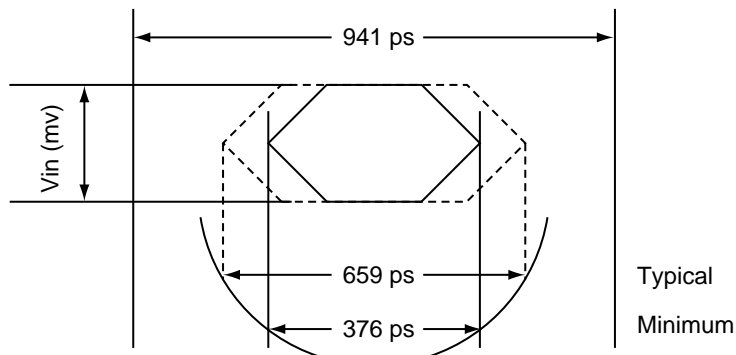

Figure 16. Receive eye diagram



## 10.0 Seagate Technology support services

### Online Services

#### *Internet*

Visit Seagate on the Internet at <http://www.seagate.com> for online information about Seagate products. You can also send e-mail with your disc or tape questions to:

*Presales:* [DiscPreSales@Seagate.com](mailto:DiscPreSales@Seagate.com) or [Tape\\_Sales\\_Support@Seagate.com](mailto:Tape_Sales_Support@Seagate.com)

*Technical support:* [DiscSupport@Seagate.com](mailto:DiscSupport@Seagate.com) or [TapeSupport@Seagate.com](mailto:TapeSupport@Seagate.com)

**SeaBOARD<sup>®</sup>** is a computer bulletin board system that contains information about Seagate disc and tape drive products and is available 24 hours daily. Set your communications software to eight data bits, no parity and one stop bit (8-N-1).

### Presales Support

Our Presales Support staff can help you determine which Seagate products are best suited for your specific application or computer system.

#### *Seagate Express*

You can purchase select tape products and tape accessories through Seagate Express 24 hours daily by calling 1-800-531-0968 or by faxing your order to: 1-972-481-4812.

### Automated Services

**SeaFONE<sup>®</sup> (1-800-SEAGATE)** is Seagate's 800 number (1-800-732-4283), which provides toll-free access to our automated self-help services. Here you'll find answers to commonly asked questions, troubleshooting tips and specifications for disc drives and tape drives. This service is available 24 hours daily and requires a touch-tone phone. International callers can reach this service by dialing 1-405-936-1234.

**SeaFAX<sup>®</sup>** is Seagate's automated FAX delivery system. Using a touch-tone phone, you can obtain technical support information by return FAX. This service is available 24 hours daily.

### Technical Support

If you need assistance installing your drive, consult your dealer. For one-on-one help, you can talk to a technical support specialist during business hours. Before calling, note your system configuration and drive model number (STxxxxx).

**SeaTDD<sup>™</sup>(1-405-936-1687)** is a telecommunications device for the deaf (TDD). You can send questions or comments 24 hours daily and exchange messages with a technical support specialist from 8:00 A.M. to 12:15 P.M. and 1:30 P.M. to 6:00 P.M. (central time) Monday through Friday.

### Customer Service (CSO)

#### *Warranty Repair*

Seagate direct OEM, Distribution and System Integrator customers should contact their Seagate service center representative for warranty information. Other customers should contact their place of purchase. Seagate offers comprehensive customer support for Seagate drives. These services are available worldwide.

#### *Authorized Service Centers*

If your drive is out of warranty, you can contact an Authorized Service Center for service or repair.

## USA/Canada/Latin America Support Services

### Presales Support

*Disc:* 1-877-271-3285 or 1-405-936-1210 FAX: 1-405-936-1683  
*Tape:* 1-800-626-6637 or 1-714-641-2500 FAX: 1-714-641-2410

### Technical Support (SeaFONE)

1-800-SEAGATE or 1-405-936-1234 (for specific product phone number)  
 FAX: *Disc:* 1-405-936-1685; *Tape:* 1-405-936-1683

### Warranty Repair

USA/Canada 1-800-468-3472 FAX: 1-405-949-6740  
 Latin America 1-405-949-7758 FAX: 1-405-949-6738

**SeaFAX** 1-800-SEAGATE  
**SeaTDD** 1-405-936-1687  
**SeaBOARD** *Disc:* 1-405-936-1600; *Tape:* 1-405-936-1630

### Authorized Service Centers

Brazil  
*MA Informatica* 55-21-516-6649 FAX: 55-21-516-5280

Canada  
*Memofix* 1-905-660-4936 FAX: 1-905-660-4951  
*Adtech* 1-905-812-8099 or 1-800-624-9857 FAX: 1-905-812-7807

## European Support Services

For European customer support, dial the toll-free number for your specific country for presales support, technical support, SeaFAX and warranty repair.

If your country is not listed here, dial our European call center at 31-20-316-7222 from 8:30 A.M. to 5:00 P.M. (European central time) Monday through Friday. The European call center is located in Amsterdam, The Netherlands.

### Call Center

Austria 0 800-20 12 90  
 Belgium 0 800-74 876  
 Denmark 80 88 12 66  
 France 0 800-90 90 52  
 Germany 0 800-182 6831  
 Ireland 1 800-55 21 22  
 Italy 1 677 90 695  
 Netherlands 0 800-732 4283  
 Norway 800-113 91  
 Poland 00 800-311 12 38  
 Spain 900-98 31 24  
 Sweden 0 207 90 073  
 Switzerland 0 800-83 84 11  
 Turkey 00 800-31 92 91 40  
 United Kingdom 0 800-783 5177

### SeaBOARD

France 33 1-48 25 35 95  
 Germany 49-89-1409331  
 United Kingdom 44-1628-478011

***Fax Services—All European Countries***

Presales/Technical Support 31-20-653-3513  
 Warranty Repair 31-20-653-4320

**Africa/Middle East Support Services**

For presales, technical support, warranty repair and FAX services in Africa and the Middle East, dial our European call center at 31-20-316-7222 from 8:30 A.M. to 5:00 P.M. (European central time) Monday through Friday, or send a FAX to 31-20-653-4320. The European call center is located in Amsterdam, The Netherlands.

**Asia/Pacific Support Services**

If the customer service number for your country is not listed here, dial our Asia/Pacific headquarters located in Singapore during business hours from 9:00 A.M. to 5:00 P.M. Singapore time.

***Technical Support***

Australia	61-2-9725-3366	FAX: 61-2-9725-4052
Hong Kong	852-2368 9918	FAX: 852-2368 7173
Japan	—	FAX: 81-3-5462-2979
Singapore	65-488-7584	FAX: 65-488-7528
Taiwan	886-2-2514-2237	FAX: 886-2-2715-2923

***SeaFAX***

Australia 61-2-9756-5170

***SeaBOARD***

Australia	61-2-9756-2359
Taiwan	886-2-2719-6075
Thailand	662-531-8111

***Warranty Repair***

Japan	81-3-5462-2904	FAX: 81-3-5462-2979
Australia and other Asia/Pacific countries	65-485-3595	FAX: 65-488-7503



## Numerics

12 volt  
 pins 49  
 3rd party reserve command 41  
 5 volt pins 49

## A

A/D Demod 30  
 Abort Sequence (ABTS) 33  
 abort task set function 33  
 AC coupling 49  
 AC power requirements 19  
 ACA active status 45  
 ACA active, faulted initiator status 45  
 Accept (ACC) 33  
 Acoustics 23  
 active LED Out signal 49  
 Actual retry count bytes command 39  
 actuator 7  
 assembly design 5  
 adaptive caching 45  
 Address Discovery (ADISC) 33  
 addresses 46  
 air cleanliness 22  
 air flow 29  
 direction 29  
 illustrated 29  
 pattern 29  
 Alternate credit model 34, 37  
 altitude limits  
 non-operating 21  
 operating 21  
 ambient temperature 28  
 ANSI documents  
 fibre channel 4  
 SCSI 4  
 arbitrated loop physical address (AL\_PA) 27  
 arbitration 27  
 asynchronous event notification 45  
 audible noise 3  
 auto write and read reallocation  
 programmable 6  
 automatic contingent allegiance 45  
 average idle current 19  
 average rotational latency 9

## B

backpanel 48  
 backplane 50  
 basic link service frames 33  
 Basic\_Accept (BA\_ACC) 33  
 Basic\_Reject (BA\_RJT) 33  
 BB 34, 37  
 BB-Credit 34, 37  
 bels 23  
 buffer

data 6  
 space 11  
 busy status 45  
 bypass circuit 17  
 Byte check command 40  
 bytes per surface 9  
 bytes per track 9

## C

cache operation 10  
 cache segments 11  
 Caching parameters page (08h) command 39  
 caching write data 11  
 Canadian Department of Communications 3  
 capacity  
 formatted 7  
 unformatted 7, 9  
 CDB Write command (2Ah) 12  
 CF 34, 37  
 Change definition command 41  
 character sync 16  
 charge pins 49  
 check condition status 45  
 Class 3 parameters 34, 37  
 class B limit 3  
 Class valid 34, 37  
 clear ACA function 33  
 clear task set function 33  
 commands supported 39  
 Common features 34, 37  
 Compare command 40  
 Concurrent sequences 34  
 condition met/good status 45  
 connector  
 illustrated 47  
 requirements 47  
 Continuously increasing offset 34, 37  
 Control mode page (0Ah) command 39  
 cooling 28, 29  
 Copy and verify command 40  
 Copy command 39  
 CRC 16  
 error 13  
 CS 34  
 Current profiles 20  
 customer service 16  
 cylinders/tracks per surface 9

## D

data block size  
 modifying the 7  
 data buffer to/from disc media 10  
 data heads  
 read/write 9  
 data page out (DPO) bit 12  
 data rate  
 internal 9

- data transfer rate 10
- data valid eye 54
- Date code page command 39
- DC power 48
  - requirements 19
- defect and error management 25
- deferred error handling 45
- description 5
- device selection IDs 27
- devices 27
- differential PECL input 54
- dimensions
  - physical 23
- Disable page out command 40
- disc rotation speed 9
- Disconnect/reconnect control (page 02h) command 39
- Download microcode and save modes (5) 40
- Download microcode mode (4) 40
- Download microcode with offsets and save mode (7) 40
- Download microcode with offsets mode (6) 40
- drive active LED connection 27
- drive characteristics 9
- drive fault LED connection 27
- drive ID 27
- drive ID/option select headers 27
- drive mounting 31
- drive orientation 28
- drive select 48
- driver signals 53
- drivers and receivers 6
- dual port support 38

## E

- effective altitude 21
- electrical
  - description of connector 48
  - signal characteristics 53
  - specifications 19
  - susceptibility 23
- electromagnetic compatibility 3
- electromagnetic interference (EMI) 13
- elevated temperatures 30
- EMI 13
- EMI requirements 3
- enable bypass
  - port A 50
  - port B 50
  - signal 50
  - state 17
- Enclosure Services interface 48
- Enclosure services page command 39
- environmental
  - interference 13
  - limits 21
  - requirements 13

- error
  - detection mechanisms, FC 16
  - management 25
  - rates 13
- error correction code
  - 96-bit Reed-Solomon 6
- Error recovery page (01h) command 39
- extended link service
  - frames 33
  - reply frames 33
- Extended sense command 39
- Extent reservation command 41

## F

- FAB 37
- Fabric Login (FLOGI) 33
- FAN 37
- fans 29
- fault LED out signal 49
- FC Interface 30
- FC-AL
  - document 4
  - interface 27, 48
  - options supported 38
  - physical interface 46
  - SCA device connector, illustrated 47
  - selective reset 45
- FCC rules and regulations 3
- FCP
  - for SCSI, document 4
  - response codes 33
  - task management functions 33
- FC-PH document 4
- features 6
  - interface 33
- Fibre Channel documents 4
- Fibre Channel Interface Manual 1, 4
- Field pointer bytes command 39
- firmware 6
  - corruption 41
- Firmware download option command 40
- Firmware numbers page command 39
- flawed sector reallocation 6
- FLOGI
  - received on Port A 36
  - received on Port B 36
- Force unit access command 40
- form factor 6
- format 27
- Format command execution time 9
- Format page (03h) command 39
- Format unit command 39
- FS 34, 35, 37
- function
  - complete, code 00 33
  - not supported, code 05 33
  - reject, code 04 33

**G**

Good status 45  
 ground  
   HDA 31  
   signal 31  
 ground shift noise 49  
 grounding 31

**H**

hard assigned arbitrated loop physical address  
   (AL\_PA) 27  
 head and disc assembly (HDA) 5, 29  
   case temperature measurement location 30  
   cooling 29  
   ground 31  
 heads  
   read/write data 9  
 hot plugging the drive 16  
 humidity limits 21  
   non-operating 21  
   operating 21

**I**

IC 34  
 ID and configuration options 6  
 Implemented operating def. page command 39  
 Information exceptions control page (1Ch) command  
   39  
 Initiator control 34  
 Inquiry command 39  
 inquiry data 42  
 installation 27  
   guide 4  
 interface 27  
   commands supported 39  
   description 46  
   error rate 13  
   errors 13  
   illustrated 46  
   physical 46  
   requirements 33  
 interleave 6  
   minimum 10  
 intermediate/condition met/good status 45  
 intermediate/good status 45  
 Intermix 34, 37  
 internal data rate 9  
 internal defects/errors 25  
 internal drive characteristics 9

**J**

J1 connector 27  
 J6 connector 27, 28  
 Jumper settings page command 39  
 jumpers 27

**L**

latency  
   average rotational 9, 10  
 LBdata 41  
 LED driver signals 53  
 Link Service Reject (LS\_RJT) 33  
 link services supported 33  
 Lock-unlock-cache command 40  
 Log select command 41  
 Log sense command 41  
 logic power 49  
 logical block address 11  
 logical block reallocation scheme 6  
 logical block size 6, 10  
 logical segments 11  
 Logout (LOGO) 33  
 loop 46, 50  
   disruption 16  
   initialization 27  
 loop position  
   FC-AL options 38  
 loop position report  
   FC-AL options 38  
 LS\_RJT 34, 37  
 LSI circuitry 6

**M**

maintenance 13  
 masking noise 23  
 maximum case temperature 30  
 maximum delayed motor start 19  
 maximum start current 19  
 maximum temperatures 30  
 mean time between failure (MTBF) 15  
 mechanical specifications 23  
 media description 6  
 media error rate  
   recoverable 13  
 minimum sector interleave 10  
 miscellaneous feature support  
   Adaptive caching 45  
   Asynchronous event notification 45  
   Automatic contingent allegiance 45  
   Deferred error handling 45  
   FC-AL selective reset 45  
   Parameter rounding 45  
   Queue tagging 45  
   Reporting actual retry count 45  
   Segmented caching 45  
   SMP = 1 in Mode Select command 45  
   Synchronized (locked) spindle operation 45  
   Zero latency read 45  
 miscellaneous status support  
   ACA active 45  
   ACA active, faulted initiator 45  
   Busy 45

- Check condition 45
- Condition met/good 45
- Good 45
- Intermediate/condition met/good 45
- Intermediate/good 45
- Reservation conflict 45
- Task set full 45
- miscorrected media data 13
- mode page 08h 11
- Mode select
  - (10) command 41
  - command 39
- Mode sense
  - (10) command 41
  - command 39
  - data, table 42, 44
- monitoring state 17
- Motor driver 30
- motor start
  - controls 50
  - option 10
- mounting 31
  - configuration dimensions 23
  - holes 31
  - orientations 28
- MTBF 13, 15
  - defined 15

## N

- N\_Port Login (PLOGI) 33
  - payload 34
  - payload values 35
- NN 34, 37
- Node Name 37
- Node name 34
- noise 23
  - audible 3
- noise immunity 20

## O

- old port state
  - FC-AL options 38
- OPEN Full Duplex
  - FC-AL options 38
- OPEN half duplex
  - FC-AL options 38
- Open sequences per exchange 34
- option configurations 27
- option selection 48
- options 7, 38
- OS 34
- out-of-plane distortion 31
- overhead time
  - for head switch 10
  - for one track cylinder switch 10

## P

- P\_LOGI
  - received on Port A 35
  - received on Port B 35
- parameter rounding 45
- pass-through state 17
- PBC 46, 50
- PBdata 41
- peak operating current 19
- peak-to-peak measurements 20
- PECL input 54
- performance characteristics
  - detailed 9
  - general 10
- performance highlights 6
- physical interface 46
  - description 46
- physical specifications 19
- PI 35, 36
- pin descriptions 48
- PN 34, 37
- port bypass circuit 17, 46, 50
- port bypass LED connection 27
- Port DIScovery 34
- Port Discovery (PDISC) 33
- port identifier field 35, 36
- port login 34
  - accept 35
- Port Name 37
- Port name (initiator's) 34
- power 49
  - dissipation 20
  - requirements, AC 19
  - requirements, DC 19
  - sequencing 20
- Power control page (1Ah) command 39
- power distribution 3
- Prefetch command 40
- prefetch/multi-segmented cache control 10
- preventive maintenance 13
- printed circuit board (PCB)
  - cooling 28
- private loop
  - FC-AL options 38
- Proc Assc 34
- Process Accept (ACC) 35
- Process Login (PRLI) 33, 35
- Process Login Accept (ACC) payload 35
- process login payload data 35
- Process Logout (PRLO) 33
- Processor 30
- product reliability
  - reduction in 30
- public loop
  - FC-AL options 38
- pull down resistor 50



**Q**

queue tagging 45

**R**

radiated emissions 31  
radio interference regulations 3  
Random relative offset 34, 37  
RCD bit 11  
Read buffer command 40  
Read capacity command 40  
Read combined header and data mode (0) 40  
Read command 39  
Read data mode (2) 40  
Read defect data command 40  
Read descriptor mode (3) 40  
Read extended command 40  
Read Link Status (RLS) 33  
Read long command 40  
read/write data heads 9  
Reassign blocks command 39  
Receive buffer field size 34, 37  
receive buffer field size 35  
Receive diagnostic results command 39  
receive eye  
    diagram 54  
receivers 49  
reference  
    components 30  
    documents 4  
Regenerate command 41  
Relative address command 40  
Release command 39  
Released (10) command 41  
reliability 6  
    and service 15  
    specifications 13  
repair and return information 16  
reporting actual retry count 45  
Request sense command 39  
reservation conflict status 45  
Reserve command 39  
Reserved (10) command 41  
return information 16  
Rezero unit command 39  
Rigid disc drive geometry page  
    command 39  
rotation speed 9  
running disparity 16

**S**

safety 3  
SCA part numbers 47  
SCSI interface  
    commands supported 39  
SCSI Interface Product Manual 3  
Search data

    equal command 40  
    high command 40  
    low command 40  
Seek command 39  
seek error  
    defined 13  
    rate 13  
Seek extended command 40  
seek performance characteristics 9  
seek time  
    average typical 9  
    full stroke typical 9  
    single track typical 9  
segmented caching 45  
SEL ID 27  
    lines 50  
    standard feature 6  
Self-Monitoring Analysis and Reporting Technology  
    7, 14  
Send diagnostics page command 39  
Sequential delivery 34, 37  
service  
    life 13, 16  
    philosophy 16  
    tools 16  
Service Options 37  
Service options 34  
Set limits command 40  
shielding 3  
shipping 16  
shock limits 21  
    non-operating 22  
    operating (abnormal) 21  
    operating (normal) 21  
    packaged 22  
signal  
    characteristics 53  
    ground 31  
    LED driver 53  
single-unit shipping pack kit 7  
SMART 7, 14  
SMP = 1 in Mode Select command 45  
SO 34, 37  
sound power 23  
spindle brake 6  
Stacked connection req. 34, 37  
standards 3  
Start unit/stop unit command 39  
start/stop time 10  
support services 55  
Supported diagnostics pages command 39, 40  
surface stiffness  
    allowable for non-flat surface 31  
switches 27  
Synchronize cache command 40  
synchronized spindle  
    operation 45

**T**

target reset function 33  
 task management functions 33  
   Abort task set 33  
   Clear ACA 33  
   Clear task set 33  
   Target reset 33  
   terminate task 33  
 task management response codes 33  
   Function complete 00 33  
   Function not supported 05 33  
   Function reject 04 33  
 task set full status 45  
 technical support services 55  
 temperature  
   limits 21  
   measurement locations 30  
   regulation 3  
   *See also* cooling  
 Temperature measurement locations 30  
 terminate task function 33  
 terminators 27  
 Test unit ready command 39  
 Third-party Process Logout (TRPLO) 33  
 tracks per inch 9  
 Translate page command 39, 40  
 transmit eye diagram 54  
 transmitters 49  
 transporting the drive 16  
 TTL input characteristics 53

**U**

UI 35, 36  
 unique identifier 35, 36  
 Unit attention page (00h) command 39  
 Unit serial number page command 39  
 unrecoverable  
   error 13  
   write error, defined 13  
 unrecovered media data 13

**V**

Valid version level 34, 37  
 Verify command 40  
 Verify error recovery page (07h) command 39  
 vibration limits 21  
   (non-operating) 22  
   operating (abnormal) 22  
   operating (normal) 22  
 Vital product data page command 39

**W**

warranty 16  
 WCE 11  
 word sync 16

Write and verify command 40  
 Write buffer command 40  
 write caching enable bit 11  
 Write combined header and data mode (0) 40  
 Write command 39  
 Write data mode (2) 40  
 write errors 13  
 Write extended command 40  
 Write long command 40  
 Write same command 41

**X**

XD read 41  
 XD write 41  
 XD write extended command 41  
 XID reassign 34  
 XP write 41

**Z**

zero latency read 45  
 zone bit recording (ZBR) 6





**Seagate Technology, Inc.**  
**920 Disc Drive, Scotts Valley, California 95066-4544, USA**  
*Publication Number: 83329350, Rev. C, Printed in USA*