



.....
Barracuda 18FC Disc Drive
.....

ST118273FC
.....

.....
Product Manual, Volume 1
.....

.....
Barracuda 18FC Disc Drive
.....

ST118273FC
.....

.....
Product Manual, Volume 1
.....

© 1997, 1998 Seagate Technology, Inc. All rights reserved
November 1998
Publication number: 77767524, Rev. B

Seagate, Seagate Technology, and the Seagate logo are registered trademarks of Seagate Technology, Inc. Barracuda, SeaFAX, SeaFONE, SeaBOARD, and SeaTDD are either trademarks or registered trademarks of Seagate Technology, Inc. or one of its subsidiaries. All other trademarks or registered trademarks are the property of their respective owners.

No part of this publication may be reproduced in any form without written permission from Seagate Technology, Inc.

Printed in the United States of America

Revision status summary sheet

Revision	Date	Writer/Engineer	Sheets Affected
A	08/04/98	L. Newman/R. Metzner	1/1, v thru viii, 1 thru 64.
B	11/24/98	L. Newman/R. Metzner	52.

Contents

1.0	Scope	1
2.0	Applicable standards and reference documentation	3
2.1	Standards	3
2.1.1	Electromagnetic compatibility	3
2.2	Electromagnetic compliance	3
2.3	Reference documents	4
3.0	General description	5
3.1	Standard features	6
3.2	Media description	6
3.3	Performance	6
3.4	Reliability	7
3.5	Unformatted and formatted capacities	7
3.6	Factory-installed accessories	7
3.7	Factory-installed options	7
3.8	User-installed accessories	7
4.0	Performance characteristics	9
4.1	Internal drive characteristics	9
4.2	Seek performance characteristics	9
4.2.1	Access time	9
4.2.2	Format command execution time for ≥ 512 -byte sectors	9
4.2.3	General performance characteristics	10
4.3	Start/stop time	10
4.4	Prefetch/multi-segmented cache control	10
4.5	Cache operation	11
4.5.1	Caching write data	11
5.0	Reliability specifications	13
5.1	Error rates	13
5.1.1	Environmental interference	13
5.1.2	Interface errors	13
5.1.3	Write errors	13
5.1.4	Seek errors	13
5.2	S.M.A.R.T.	14
5.3	Reliability and service	15
5.3.1	Mean time between failure (MTBF)	15
5.3.2	Field failure rate vs time	15
5.3.3	Preventive maintenance	16
5.3.4	Service life	16
5.3.5	Service philosophy	16
5.3.6	Service tools	16
5.3.7	Product warranty	16
5.3.8	Hot plugging the drive	17
6.0	Physical/electrical specifications	19
6.1	AC power requirements	19
6.2	DC power requirements	19
6.2.1	Conducted noise immunity	20
6.2.2	Power sequencing	20
6.2.3	Current profiles	20
6.3	Power dissipation	20
6.4	Environmental limits	21
6.4.1	Temperature	21
6.4.2	Relative humidity	21
6.4.3	Effective altitude (sea level reference)	21

6.4.4	Shock and vibration	21
6.4.5	Air cleanliness	22
6.5	Electromagnetic susceptibility	23
6.6	Mechanical specifications	23
7.0	Defect and error management	25
7.1	Drive internal defects/errors	25
7.2	Drive error recovery procedures	25
7.3	FC-AL system errors	26
8.0	Installation	27
8.1	Drive ID/option selection	27
8.2	LED connections	27
8.2.1	J6 connector requirements	28
8.3	Drive orientation	28
8.4	Cooling	28
8.4.1	Air flow	28
8.5	Drive mounting	31
8.6	Grounding	31
9.0	Interface requirements	33
9.1	FC-AL features	33
9.1.1	Fibre Channel link service frames	33
9.1.2	Fibre Channel task management functions	33
9.1.3	Fibre Channel task management responses	33
9.1.4	Fibre Channel port login	34
9.1.5	Fibre Channel port login accept	35
9.1.6	Fibre Channel Process Login (PRLI)	35
9.1.7	Fibre Channel Process Accept (ACC)	35
9.1.8	Fibre Channel fabric login	36
9.1.9	Fibre Channel fabric accept login	37
9.1.10	Fibre Channel Arbitrated Loop options	38
9.2	Dual port support	38
9.3	SCSI commands supported	39
9.3.1	Inquiry data	42
9.3.2	Mode Sense data	42
9.4	Miscellaneous operating features and conditions	45
9.5	FC-AL physical interface	46
9.5.1	Physical characteristics	46
9.5.2	Connector requirements	47
9.5.3	Electrical description	48
9.5.4	Pin descriptions	48
9.5.5	FC-AL transmitters and receivers	49
9.5.6	Power	49
9.5.7	Fault LED Out	49
9.5.8	Active LED Out	49
9.5.9	Enable port bypass signals	50
9.5.10	Motor start controls	50
9.5.11	SEL_6 through SEL_0 ID lines	50
9.6	Signal characteristics	52
9.6.1	TTL characteristics	52
9.6.2	LED driver signals	52
9.6.3	Differential PECL output	52
9.6.4	Differential PECL input	53
10.0	Seagate Technology support services	55

List of Figures

Figure 1.	Barracuda 18FC family disc drive	1
Figure 2.	Barracuda 18FC disc drive	5
Figure 3.	Typical Barracuda 18FC drive +12V current profile	20
Figure 4.	Mounting configuration dimensions	23
Figure 5.	Physical interface	27
Figure 6.	LED indicator connector	28
Figure 7.	Air flow	29
Figure 8.	PCBA temperature measurement locations	30
Figure 9.	HDA case temperature measurement location	30
Figure 10.	Physical interface	46
Figure 11.	Port bypass circuit physical interconnect	46
Figure 12.	FC-AL SCA device connector dimensions	47
Figure 13.	J6 connector dimensions	47
Figure 14.	FC-AL transmitters and receivers	49
Figure 15.	Transmit eye diagram	53
Figure 16.	Receive eye diagram	53

1.0 Scope

This manual describes Seagate® Barracuda™ 18FC (Fibre Channel) disc drives.

Barracuda 18FC drives support the Fibre Channel Arbitrated Loop and SCSI Fibre Channel Protocol specifications to the extent described in this manual. The *Fibre Channel Interface Manual* (part number 77767496) describes the general Fibre Channel Arbitrated Loop characteristics of this and other Seagate Fibre Channel drives.

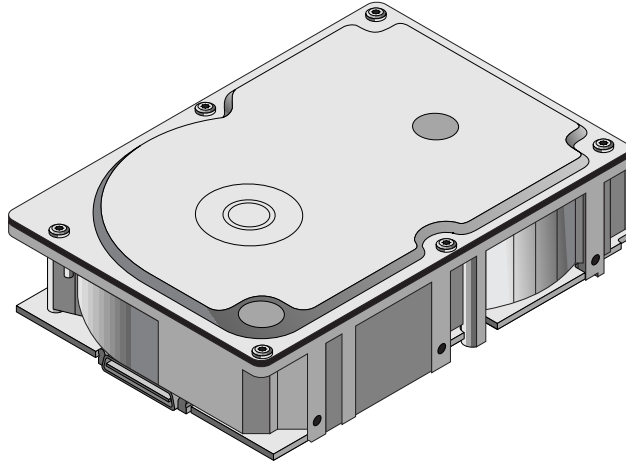

Figure 1. Barracuda 18FC family disc drive

2.0 Applicable standards and reference documentation

The drive has been developed as a system peripheral to the highest standards of design and construction. The drive depends upon its host equipment to provide adequate power and environment in order to achieve optimum performance and compliance with applicable industry and governmental regulations. Special attention must be given in the areas of safety, power distribution, shielding, audible noise control, and temperature regulation. In particular, the drive must be securely mounted in order to guarantee the specified performance characteristics. Mounting by bottom holes must meet the requirements of Section 8.5.

2.1 Standards

The Barracuda 9FC family complies with Seagate standards as noted in the appropriate sections of this manual and the Seagate *Fibre Channel Interface Manual*, part number 77767496.

The Barracuda 18FC disc drive is a UL recognized component per UL1950, CSA certified to CAN/CSA C22.2 No. 950-95, and VDE certified to VDE 0805 and EN60950.

2.1.1 Electromagnetic compatibility

The drive, as delivered, is designed for system integration and installation into a suitable enclosure prior to use. As such the drive is supplied as a subassembly and is not subject to Subpart B of Part 15 of the FCC Rules and Regulations nor the Radio Interference Regulations of the Canadian Department of Communications.

The design characteristics of the drive serve to minimize radiation when installed in an enclosure that provides reasonable shielding. As such, the drive is capable of meeting the Class B limits of the FCC Rules and Regulations of the Canadian Department of Communications when properly packaged. However, it is the user's responsibility to assure that the drive meets the appropriate EMI requirements in their system. Shielded I/O cables may be required if the enclosure does not provide adequate shielding. If the I/O cables are external to the enclosure, shielded cables should be used, with the shields grounded to the enclosure and to the host controller.

2.1.1.1 Electromagnetic susceptibility

As a component assembly, the drive is not required to meet any susceptibility performance requirements. It is the responsibility of those integrating the drive within their systems to perform those tests required and design their system to ensure that equipment operating in the same system as the drive or external to the system does not adversely affect the performance of the drive. See Section 5.1.1 on page 13 and Table 1, DC power requirements, on page 19.

2.2 Electromagnetic compliance

Seagate uses an independent laboratory to confirm compliance with the directives/standards for CE Marking and C-Tick Marking. The drive was tested in a representative system for typical applications. The selected system represents the most popular characteristics for test platforms. The system configurations include:

- 486, Pentium, and PowerPC microprocessors
- 3.5-inch floppy disc drive
- Keyboard
- Monitor/display
- Printer
- External modem
- Mouse

Although the test system with this Seagate model complies with the directives/standards, we cannot guarantee that all systems will comply. The computer manufacturer or system integrator shall confirm EMC compliance and provide the appropriate marking for their product.

Electromagnetic compliance for the European Union

If this model has the CE Marking it complies with the European Union requirements of the Electromagnetic Compatibility Directive 89/336/EEC of 03 May 1989 as amended by Directive 92/31/EEC of 28 April 1992 and Directive 93/68/EEC of 22 July 1993.

Australian C-Tick

If this model has the C-Tick Marking it complies with the Australia/New Zealand Standard AS/NZS3548 1995 and meets the Electromagnetic Compatibility (EMC) Framework requirements of Australia's Spectrum Management Agency (SMA).

2.3 Reference documents

Barracuda 18FC Installation Guide

Seagate part number: 77767525

Fibre Channel Interface Manual

Seagate part number: 77767496

ANSI Fibre Channel Documents

X3.230-1994	FC Physical and Signaling Interface (FC-PH)
X3.297.1997	FC-PH-2 Fibre Channel Physical and Signaling Interface-2
X3.303.199X	FC-PH-3 Fibre Channel Physical and Signaling Interface-3
X3.272-1996	FC Arbitrated Loop (FC-AL)
X3.269-1996	Fibre Channel Protocol for SCSI (FCP)
NCITS TR-19	Private Loop SCSI Direct Attach
NCITS TR-20	Fabric Loop Attachment (FC-FLA)
SFF-8045	Specification for 40-pin SCA-2 Connector with Parallel Selection
SFF-8067	Specification for 40-pin SCA-2 Connector with Bidirectional Enclosure Services Interface.

ANSI Small Computer System Interface (SCSI) Documents

X3.131-1994	(SCSI-2)
X3.270-199X	(SCSI-3) Architecture Model
X3.XXX-199X	(SCSI-3) Enclosure Services

In case of conflict between this document and any referenced document, this document takes precedence.

3.0 General description

Barracuda 18FC drives are random access storage devices designed to support the Fibre Channel Arbitrated Loop (FC-AL) and SCSI Fibre Channel Protocol as described in the ANSI specifications, this document, and the *Fibre Channel Interface Manual* (part number 77767496) which describes the general interface characteristics of this drive. ST118273FC drives are classified as intelligent peripherals and provide level 2 conformance (highest level) with the ANSI SCSI-1 standard.

You can view the Fibre Channel interface simply as a transport vehicle for the supported command set (ST118273FC drives use the SCSI command set). In fact, the Fibre Channel interface is unaware of the content or meaning of the information being transported. It simply packs the SCSI commands in frames, transports them to the appropriate devices, and provides error checking to ensure that the information reaches its destination accurately. Refer to the documents referenced in Section 2.3 if you require additional information about the Fibre Channel interface, FC-AL topology, or the SCSI fibre channel protocol.

The head and disc assembly (HDA) is environmentally sealed at the factory. Air recirculates within the HDA through a non-replaceable filter to maintain a contamination-free HDA environment.

See Figure 2 for an exploded view of the drive. Never disassemble the HDA. This exploded view is for information only. Do not attempt to service items in the sealed enclosure (heads, media, actuator, etc.) as this requires special facilities. The drive contains no parts replaceable by the user and opening the HDA for any reason voids your warranty.

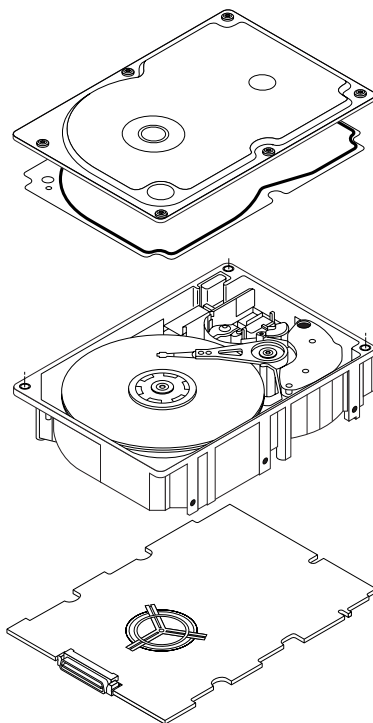

Figure 2. Barracuda 18FC disc drive

Barracuda 18FC drives use a dedicated landing zone at the innermost radius of the media to eliminate the possibility of destroying or degrading data by landing in the data zone. The heads automatically go to the landing zone when power is removed from the drive.

An automatic shipping lock prevents potential damage to the heads and discs that results from movement during shipping and handling. The shipping lock disengages and the head load process begins when power is applied to the drive.

The drives also use a high-performance actuator assembly design that provides excellent performance with minimum power dissipation.

3.1 Standard features

Barracuda 18FC drives have the following standard features:

- Integrated dual port FC-AL controller
- Concurrent dual port transfers
- Support for FC arbitrated loop and private loop attachment
- Differential copper FC drivers and receivers
- Downloadable firmware using the FC-AL interface
- Drive selection ID and configuration options are set on the FC-AL backpanel or through interface commands. Jumpers are not used on the drive.
- Fibre Channel worldwide name uniquely identifies the drive and each port
- User-selectable logical block size (512 to 4,096 bytes)
- Selectable frame sizes from 128 to 2,112 bytes
- Industry standard 3.5-inch half height form factor dimensions
- Programmable logical block reallocation scheme
- Flawed logical block reallocation at format time
- Programmable auto write and read reallocation
- Reed-Solomon error correction
- Sealed head and disc assembly (HDA)
- No preventive maintenance or adjustments required
- Dedicated head landing zone
- Automatic shipping lock
- Embedded Grey Code track address to eliminate seek errors
- Self-diagnostics performed at power on
- 1:1 interleave
- Zone bit recording (ZBR)
- Vertical, horizontal, or top down mounting
- Dynamic spindle brake
- 1,024 Kbyte data buffer (see Section 4.5)
- Embedded servo design
- Supports SCSI enclosure services via interface connector
- Supports up to 32 initiators
- Reallocation of defects on command (Port Format)
- Fibre Channel interface transports SCSI protocol

3.2 Media description

The media used on the drive has a diameter of approximately 95 mm (approximately 3.7 inches). The aluminum substrate is coated with a thin film magnetic material, overcoated with a proprietary protective layer for improved durability and environmental protection.

3.3 Performance

- Programmable multi-segmentable cache buffer
- 106 Mbytes/sec maximum instantaneous data transfers per port
- 7,200 RPM spindle; average latency = 4.17 msec
- Command queuing of up to 128 commands
- Background processing of queue
- Supports start and stop commands
- Adaptive seek velocity; improved seek performance

3.4 Reliability

- 1,000,000 hour MTBF
- LSI circuitry
- Balanced low mass rotary voice coil actuator
- Self-Monitoring Analysis and Reporting Technology (S.M.A.R.T.)
- Dithering

3.5 Unformatted and formatted capacities

Standard OEM models are formatted to 512 bytes per block. You can order other capacities by requesting a different sparing scheme and logical block size.

The standard OEM model capacities are listed below.

	Formatted	Unformatted
ST118273FC	18.21 Gbytes	23.14 Gbytes

Users having the necessary equipment may modify the data block size before issuing a format command and obtain different formatted capacities than those listed. The ST118273FC drives use a zone sparing scheme. The drives are divided into frequency zones with a variable number of spares in each zone.

3.6 Factory-installed accessories

OEM standard drives are shipped with the *Barracuda 18FC Installation Guide* (part number 77767525).

3.7 Factory-installed options

You may order the following items which are incorporated at the manufacturing facility during production or packaged before shipping:

- Single-unit shipping pack. The drive is normally shipped in bulk packaging to provide maximum protection against transit damage. Units shipped individually require additional protection as provided by the single unit shipping pack. Users planning single unit distribution should specify this option.

3.8 User-installed accessories

The following accessories are available. All kits may be installed in the field.

- Evaluation kit, part number 73473641.
This kit provides an adapter card ("T-card") to allow cable connections for two FC ports and DC power. Two twin axial cables, 6 feet in length, are included for the input and output connections to the FC interface.

4.0 Performance characteristics

This section provides detailed information concerning performance-related characteristics and features of ST118273FC drives.

4.1 Internal drive characteristics

	ST118273FC	
Drive capacity	23.14Gbytes (unformatted)
	18.21Gbytes (formatted with 512-byte logical blocks)
Read/write data heads	20	
Bytes per track	155,000Bytes (average, unformatted)
Bytes per surface	1,165Mbytes (unformatted)
Cylinders/tracks per surface	7,501Tracks (user accessible)
Tracks per inch	8,250TPI
Internal data rate	120-190Mbits/sec (variable with zone)
Disc rotation speed	7,200rpm (\pm 0.5%)
Avg rotational latency	4.17msec

4.2 Seek performance characteristics

See section 9.5, "FC-AL physical interface" on page 46 and the *Fibre Channel Interface Manual* (part number 77767496) for additional timing details.

4.2.1 Access time

		Including controller overhead ^{1, 2} (msec)	
		Read	Write
Average	Typical ^{3,4}	7.9	8.7
	Maximum ⁵	9.3	9.6
Single track	Typical ^{3,4}	1.1	1.4
	Maximum ⁴	1.3	1.6
Full stroke	Typical ^{3,4}	16	18
	Maximum ⁴	18.5	20

1. Execution time measured from receipt of the FCP command to the FCP response.
2. Assumes no errors and no sector has been relocated.
3. Typical access times are measured under nominal conditions of temperature, voltage, and horizontal orientation as measured on a representative sample of drives.
4. Access time = controller overhead + average seek time.
Access to data = controller overhead + average seek time + latency time.
5. Maximum times are specified over the worst case conditions of temperature, voltage margins, and drive orientation. When comparing specified access times, care should be taken to distinguish between typical access times and maximum access times. The best comparison is obtained by system benchmark tests conducted under identical conditions. Maximum times do not include error recovery.

4.2.2 Format command execution time for \geq 512-byte sectors

	ST118273FC
Maximum (with verify)	80 minutes
Maximum (without verify)	40 minutes

4.2.3 General performance characteristics

	ST118273FC
Minimum sector interleave	1 to 1
Data buffer to/from disc media (one 512-byte logical block)*	
Minimum	15.2 MBytes/sec
Average	20.4 MBytes/sec
Maximum	23.7 MBytes/sec
Data buffer transfer rate to/from disc media (<1 track)*	
Minimum	10.8 MBytes/sec
Average	16.0 MBytes/sec
Maximum	17.0 MBytes/sec
Fibre Channel Interface maximum instantaneous transfer rate	106 Mbytes/sec* per port (dual port = 212 Mbytes/sec*)
Logical block sizes	
Default is 512-byte data blocks	
Variable 512 to 4,096 bytes per sector in even number increments	
Read/write consecutive sectors on a track	Yes
Overhead time for head switch in sequential mode	1.2 msec
Overhead time for one track cylinder switch in sequential mode	1.2 msec (typical)
Average rotational latency	4.17 msec

*Assumes no errors and no relocated logical blocks.

4.3 Start/stop time

If the Motor Start option is disabled, the drive becomes ready within 31 seconds after DC power is applied. If a recoverable error condition is detected during the start sequence, the drive executes a recovery procedure and the time to become ready may exceed 31 seconds. During the start sequence, the drive responds to some commands over the FC-AL interface. Stop time is less than 31 seconds (maximum) from removal of DC power.

If the Motor Start option is enabled, the internal controller accepts the commands listed in the *Fibre Channel Interface Manual* less than 3 seconds after DC power has been applied. After the Motor Start command has been received, the drive becomes ready for normal operations within 13 seconds (excluding the error recovery procedure). The Motor Start command can also be used to command the drive to stop the spindle.

There is no power control switch on the drive.

4.4 Prefetch/multi-segmented cache control

The drive provides a prefetch/multi-segmented cache algorithm that in many cases can enhance system performance. To select this feature the host sends the Mode Select command with the proper values in the applicable bytes in page 08h. Default is prefetch and read cache enabled.

If the Prefetch feature is enabled, data in contiguous logical blocks on the disc immediately beyond that which was requested by a Read command are retrieved and stored in the buffer for immediate transfer from the buffer to the host on subsequent Read commands that request those logical blocks (this is true even if cache operation is disabled). To enable Prefetch, use Mode Select page 08h, byte 12, bit 5 (Disable Read Ahead - DRA bit). DRA bit = 0 enables prefetch.

Since data that is prefetched replaces data already in some buffer segments, the host can limit the amount of prefetch data to optimize system performance. The Max Prefetch field (bytes 8 and 9) limits the amount of prefetch. The drive does not use the Prefetch Ceiling field (bytes 10 and 11).

4.5 Cache operation

Note. Refer to the *Fibre Channel Interface Manual* for more detail concerning the cache bits.

Of the 1,024 Kbytes physical buffer space in the drive, 967.5 Kbytes can be used as a cache. The cache can be divided into logical segments from which data is read and to which data is written.

The drive keeps track of the logical block addresses of the data stored in each segment of the cache. If the cache is enabled (see RCD bit in the *Fibre Channel Interface Manual*), data requested by the host with a read command is retrieved from the cache, if possible, before any disc access is initiated. Data in contiguous logical blocks immediately beyond that requested by the Read command can be retrieved and stored in the cache for immediate transfer to the initiator on subsequent read commands. This is referred to as the prefetch operation. Since data that is prefetched may replace data already in the cache segment, an initiator can limit the amount of prefetch data to optimize system performance. The drive never prefetches more sectors than the number specified in bytes 8 and 9 of Mode page 08h. If the cache is not enabled, 967.5 Kbytes of the buffer are used as a circular buffer for read/writes, with no prefetch operation and no segmented cache operation.

The following is a simplified description of the prefetch/cache operation:

Case A—read command is received and the first logical block is already in cache:

1. Drive transfers to the initiator the first logical block requested plus all subsequent contiguous logical blocks that are already in the cache. This data may be in multiple segments.
2. When a requested logical block is reached that is not in any segment, the drive fetches it and any remaining requested logical block addresses from the disc and puts them in a segment of the cache. The drive transfers the remaining requested logical blocks from the cache to the initiator in accordance with the “buffer-full” ratio specification given in Mode Select Disconnect/Reconnect parameters, page 02h.
3. The drive prefetches additional logical blocks contiguous to those transferred in step 2 above and stores them in the segment. The drive stops filling the segment when the maximum prefetch value has been transferred.

Case B—read command is received and the first logical block address requested is not in any segment of the cache.

1. The drive fetches the requested logical blocks from the disc and transfers them into a segment, and then from there to the initiator in accordance with the “buffer-full” ratio specification given in Mode Select Disconnect/Reconnect parameters, page 02h.
2. The drive prefetches additional logical blocks contiguous to those transferred in Case A, step 2 above and stores them in the segment. The drive stops filling the segment when the maximum prefetch value has been transferred.

During a prefetch, the drive crosses a cylinder boundary to fetch data only if the Discontinuity (DISC) bit is set to 1 in bit 4 of byte 2 of the Mode Select parameters page 08h. Default is zero for bit 4.

Each cache segment is actually a self-contained circular buffer whose length is an integer number of logical blocks. The wrap-around capability of the individual segments greatly enhances the cache's overall performance, allowing a wide range of user-selectable configurations. The drive supports operation of any integer number of segments from 1 to 16. Divide the 967.5 Kbytes in the buffer by the number of segments to get the segment size. Default is 3 segments.

Note. The size of each segment is not reported by Mode Sense command page 08h, bytes 14 and 15. The value 0XFFFF is always reported regardless of the actual size of the segment. Sending a size specification using the Mode Select command (bytes 14 and 15) does not set up a new segment size. If the STRICT bit in Mode page 00h (byte 2, bit 1) is set to one, the drive responds as it does for any attempt to change an unchangeable parameter.

4.5.1 Caching write data

Write caching is a write operation by the drive that makes use of a drive buffer storage area where the data to be written to the medium is stored while the drive performs the Write command.

Write caching is enabled independently of read caching. Write caching is enabled by default. To disable the write cache, use the Write Caching Enable (WCE) bit.

For write caching, the same buffer space and segmentation is used as set up for read functions. When a write command is issued, the cache is first checked to see if any logical blocks that are to be written are already stored in the cache from a previous read or write command. If there are, the respective cache segments are cleared. The new data is cached for subsequent read commands.

If a 10-byte CDB Write command (2Ah) is issued with the data page out (DPO) bit set to 1, no write data is cached, but the cache segments are still checked and cleared, if need be, for any logical blocks that are being written.

If the number of write data logical blocks exceeds the size of the segment being written into when the end of the segment is reached, the data is written into the beginning of the same cache segment, overwriting the data that was written there at the beginning of the operation. However, the drive does not overwrite data that has not yet been written to the medium.

5.0 Reliability specifications

The following reliability specifications assume correct host and drive operational interface, including all interface timings, power supply voltages, and environmental requirements.

Seek error rate:	Less than 10 errors in 10^8 seeks
Recoverable media error rate (using OEM default settings):	Less than 10 errors in 10^{12} bits transferred
Unrecovered media data:	Less than 1 sector in 10^{15} bits transferred
Miscorrected media data:	Less than 1 sector in 10^{21} bits transferred
Interface error rate:	Less than 1 error in 10^{12} bits transferred with minimum receive eye. Less than 1 error in 10^{14} bits transferred with typical receive eye. See Section 9.6.4, "Differential PECL input" on page 53.
MTBF:	1,000,000 hours
Service life:	5 years
Preventive maintenance:	None required

5.1 Error rates

The error rates stated in this manual assume the following:

- The drive is operated in accordance with this manual using DC power as defined in paragraph 6.2, "DC power requirements."
- The drive has been formatted with the FC-AL format commands.
- Errors caused by media defects or host system failures are excluded from error rate computations.

5.1.1 Environmental interference

When evaluating systems operation under conditions of electromagnetic interference (EMI), the performance of the drive within the system is considered acceptable if the drive does not generate an unrecoverable condition.

An unrecoverable error, or condition, is defined as one that:

- is not detected and corrected by the drive itself, or
- is not detected from the error or fault status provided through the drive or FC-AL interface, or
- is not recovered by normal drive or system recovery procedures without operator intervention.

5.1.2 Interface errors

An interface error is defined as a failure of the receiver on a port to recover the data as transmitted by the device port connected to the receiver. The error may be detected as a running disparity error, illegal code, loss of word sync, or CRC error. The total error rate for a loop of devices is the sum of the individual device error rates.

5.1.3 Write errors

Write errors can occur as a result of media defects, environmental interference, or equipment malfunction. Therefore, write errors are not predictable as a function of the number of bits passed.

If an unrecoverable write error occurs because of an equipment malfunction in the drive, the error is classified as a failure affecting MTBF. Unrecoverable write errors are those that cannot be corrected within two attempts at writing the record with a read verify after each attempt (excluding media defects).

5.1.4 Seek errors

A seek error is defined as a failure of the drive to position the heads to the addressed track. There must be no more than ten recoverable seek errors in 10^8 physical seek operations. After detecting an initial seek error, the drive automatically reseek to the addressed track up to three times. If a reseek is successful, the Extended Sense reports a seek positioning error (15h), no seek complete error (02h), or track follow error (09h), and the sense key reports a recovered error (01h). If all three reseek fail, a seek positioning error (15h) is reported

with a Medium (03h) or Hardware error (04h) reported in the Sense Key. This is an unrecoverable seek error. Unrecoverable seek errors are classified as failures for MTBF calculations.

5.2 S.M.A.R.T.

S.M.A.R.T. is an acronym for Self-Monitoring Analysis and Reporting Technology. This technology is intended to recognize conditions that indicate imminent drive failure and is designed to provide sufficient warning of a failure to allow you to back up the data before an actual failure occurs.

Note. The drive's firmware monitors specific attributes for degradation over time but can't predict instantaneous drive failures.

Each monitored attribute has been selected to monitor a specific set of failure conditions in the operating performance of the drive and the thresholds are optimized to minimize "false" and "failed" predictions.

Controlling S.M.A.R.T.

The operating mode of S.M.A.R.T. is controlled by the DEXCPT and PERF bits on the Informational Exceptions Control mode page (1Ch). Use the DEXCPT bit to enable or disable the S.M.A.R.T. feature. Setting the DEXCPT bit disables all S.M.A.R.T. functions. When enabled, S.M.A.R.T. collects on-line data as the drive performs normal read and write operations. When the PERF bit is set, the drive is considered to be in "On-line Mode Only" and will not perform off-line functions.

You can measure off-line attributes and force the drive to save the data by using the RTZ command. Forcing S.M.A.R.T. resets the timer so that the next scheduled interrupt is in two hours.

You can interrogate the drive through the host to determine the time remaining before the next scheduled measurement and data logging process occurs. To accomplish this, issue a Log Sense command to log page 0x3E. This allows you to control when S.M.A.R.T. interruptions occur. Forcing S.M.A.R.T. with the RTZ command resets the timer.

Performance impact

S.M.A.R.T. attribute data is saved to the disc so the events that caused a predictive failure can be recreated. The drive measures and saves parameters once every two hours subject to an idle period on the interface. The process of measuring off-line attribute data and saving data to the disc is uninterruptable. The maximum on-line only (DEXCPT = 0; PERF = 1) processing delay is 35 msec. The maximum fully-enabled (DEXCPT = 0, PERF = 0) processing delay is 220 msec.

Reporting control

Reporting is controlled in the Informational Exceptions Control mode page (1Ch). Subject to the reporting method, the firmware will issue to the host an 01-5Dxx sense code. The error code is preserved through bus resets and power cycles.

Attribute	FRU code	Predictive failure description
LBA reassignment	04	LBA reassignment exceeding limits
Read data errors	32	Read data errors exceeding limits
Recovered TAs	37	ERP TAs exceeding limits
Preamp detectable TAs	38	WUS TAs exceeding limits
Seek errors	43	Seek error rate exceeding limits
Spin-up errors	5B	Spin-up retry count exceeding limits

Determining rate

S.M.A.R.T. monitors the rate at which errors occur and signals a predictive failure if the rate of degraded errors increases to an unacceptable level. To determine rate, error events are logged and compared to the number of total operations for a given attribute. The interval defines the number of operations over which to measure the rate. The counter that keeps track of the current number of operations is referred to as the Interval Counter.

S.M.A.R.T. measures error rates. All errors for each monitored attribute are recorded. A counter keeps track of the number of errors for the current interval. This counter is referred to as the Failure Counter.

Error rate is the number of errors per operation. The algorithm that S.M.A.R.T. uses to record rates of error is to set thresholds for the number of errors and their interval. If the number of errors exceeds the threshold before the interval expires, the error rate is considered to be unacceptable. If the number of errors does not exceed the threshold before the interval expires, the error rate is considered to be acceptable. In either case, the interval and failure counters are reset and the process starts over.

Predictive failures

S.M.A.R.T. signals predictive failures when the drive is performing unacceptably for a period of time. The firmware keeps a running count of the number of times the error rate for each attribute is unacceptable. To accomplish this, a counter is incremented each time the error rate is unacceptable and decremented (not to exceed zero) whenever the error rate is acceptable. If the counter continually increments such that it reaches the predictive threshold, a predictive failure is signaled. This counter is referred to as the Failure History Counter. There is a separate Failure History Counter for each attribute.

5.3 Reliability and service

The reliability of Barracuda 18FC disc drives can be enhanced by ensuring that the drive receives adequate cooling. This section provides recommended air-flow information, temperature measurements, and other information, which you can use to enhance the service life of the drive.

5.3.1 Mean time between failure (MTBF)

The production disc drive achieves an MTBF of 1,000,000 hours when operated in an environment that ensures the case temperatures specified in Section 8.4.1 are not exceeded. Short-term excursions up to the specification limits of the operating environment will not affect MTBF performance. Operating the drive at case temperatures above these values will adversely affect the drive's ability to meet specifications. See section 6.4, "Environmental limits" on page 21.

The following expression defines MTBF:

$$\text{MTBF} = \frac{\text{Estimated power-on operating hours in the period}}{\text{Number of drive failures in the period}}$$

Estimated power-on operating hours means the estimated total power-on hours (POH) for all drives in service. Drive failure means any stoppage or substandard performance caused by drive malfunction.

- 8,640 POH per year
- 250 average on/off cycles per year
- Read/seek/write operation during 20% of POH
- Operating at nominal voltages

Data is calculated on a rolling-average base for a minimum period of six months.

5.3.2 Field failure rate vs time

The expected field failure rate is listed below. Drive utilization will vary. An estimate range of utilization is:

- 720 POH per month
- 250 on/off cycles per year
- Read/seek/write operation 20% of POH
- System provides adequate cooling to ensure the case temperatures specified in Figures 8 and 9 are not exceeded. Short term excursions up to the specification limits of the operating environment will not affect MTBF performance.

Month	Parts per million (PPM)
1	2,364
2	1,422
3	1,403
4	1,391
5	1,317
6	1,255
7	1,162
8+	1,025

Failure rate is calculated as follows:

- No system-induced failures counted
- PPM targets include 30% no defect found and handling failures
- Based on 1,000,000 MTBF and 720 POH per month
- Month 1's rate includes a 300 PPM installation failure

5.3.3 Preventive maintenance

No routine scheduled preventive maintenance is required.

5.3.4 Service life

The drive has a useful service life of five years. Depot repair or replacement of major parts is permitted during the lifetime.

5.3.5 Service philosophy

Special equipment is required to repair the drive HDA. To achieve the above service life, repairs must be performed only at a properly equipped and staffed Seagate service and repair facility. Troubleshooting and repair of PCBs in the field is not recommended because of the extensive diagnostic equipment required for effective servicing. The drive warranty is voided if the HDA is opened.

5.3.6 Service tools

No special tools are required for site installation or recommended for site maintenance. The depot repair philosophy of the drive precludes the necessity for special tools. Field repair of the drive is not practical because users cannot purchase individual parts for the drive.

5.3.7 Product warranty

Beginning on the date of shipment to the customer and continuing for a period of five years, Seagate warrants that each product (including components and subassemblies) that fails to function properly under normal use due to defect in materials or workmanship or due to nonconformance to the applicable specifications will be repaired or replaced, at Seagate's option and at no charge to the customer, if returned by customer at customer's expense to Seagate's designated facility in accordance with Seagate's warranty procedure. Seagate will pay for transporting the repair or replacement item to the customer. For more detailed warranty information, refer to the standard terms and conditions of purchase for Seagate products on your purchase documentation.

The remaining warranty for a particular drive can be determined by calling Seagate Customer Service at 1-800-468-3472. You can also determine remaining warranty using the Seagate web site (www.seagate.com). The drive serial number is required to determine remaining warranty information.

Shipping

When transporting or shipping a drive, use only a Seagate-approved container. Keep your original box. Seagate approved containers are easily identified by the Seagate Approved Package label. Shipping a drive in a non-approved container voids the drive warranty.

Seagate repair centers may refuse receipt of components improperly packaged or obviously damaged in transit. Contact your authorized Seagate distributor to purchase additional boxes. Seagate recommends shipping by an air-ride carrier experienced in handling computer equipment.

Product repair and return information

Seagate customer service centers are the only facilities authorized to service Seagate drives. Seagate does not sanction any third-party repair facilities. Any unauthorized repair or tampering with the factory seal voids the warranty.

5.3.8 Hot plugging the drive

Inserting and removing the drive on the FC-AL will interrupt loop operation. The interruption occurs when the receiver of the next device in the loop must synchronize to a different input signal. FC error detection mechanisms, character sync, running disparity, word sync, and CRC are able to detect any error. Recovery is initiated based on the type of error.

The disc drive defaults to the FC-AL Monitoring state, Pass-through state, when it is powered-on by switching the power or hot plugged. The control line to an optional port bypass circuit (external to the drive), defaults to the Enable Bypass state. If the bypass circuit is present, the next device in the loop will continue to receive the output of the previous device to the newly inserted device. If the bypass circuit is not present, loop operation is temporarily disrupted until the next device starts receiving the output from the newly inserted device and regains synchronization to the new input.

The Pass-through state is disabled while the drive performs self test of the FC interface. The control line for an external port bypass circuit remains in the Enable Bypass state while self test is running. If the bypass circuit is present, loop operation may continue. If the bypass circuit is not present, loop operation will be halted while the self test of the FC interface runs.

When the self test completes successfully, the control line to the bypass circuit is disabled and the drive enters the FC-AL Initializing state. The receiver on the next device in the loop must synchronize to output of the newly inserted drive.

If the self-test fails, the control line to the bypass circuit remains in the Enable Bypass state.

Note. It is the responsibility of the systems integrator to assure that no temperature, energy, voltage hazard, or ESD potential hazard is presented during the hot connect/disconnect operation. Discharge the static electricity from the drive carrier prior to inserting it into the system.

Caution. The drive motor must come to a complete stop prior to changing the plane of operation. This time is required to insure data integrity.

6.0 Physical/electrical specifications

This section provides information relating to the physical and electrical characteristics of the drive.

6.1 AC power requirements

None.

6.2 DC power requirements

The voltage and current requirements for a single drive are shown below. On-board +3.3V current is derived on the drive. Values indicated apply at the drive connector. Parameters, other than spindle start, are measured after a 10-minute warm-up.

Table 1: DC power requirements

Voltage regulation	Notes [5]	ST118273FC	
		+5V ±5% (Amps)	+12V ±5% ^[2] (Amps)
Avg idle current	[1] [7] [8]	1.50	0.80
Max start current (peak DC)	[3]	1.70	3.1
Delayed motor start (max)	[1] [4]	1.45	0.03
Operating current:			
Typical	[1] [6]	1.65	1.25
Maximum	[1]	1.70	1.30
Max (peak)		2.00	3.1

- [1] Measured with average reading DC ammeter. Instantaneous +12V current peaks will exceed these values.
- [2] A -10% tolerance is allowed during initial spindle start but must return to ±5% before reaching 7,200 RPM. The ±5% must be maintained after the drive signifies that its power-up sequence has been completed and that the drive is able to accept selection by the host initiator.
- [3] See +12V current profile in Figure 3.
- [4] This condition occurs when the Motor Start option is enabled and the drive has not yet received a Start Motor command.
- [5] See paragraph 6.2.1, "Conducted noise immunity." Specified voltage tolerance includes ripple, noise, and transient response.
- [6] Operating condition is defined as random seek reads of 64 blocks.
- [7] All power saving features enabled.
- [8] During idle, the heads are relocated every 60 seconds to a random location within the band from track 0 to one-fourth of maximum track. This will result in a random variation in the +12 volt idle current of 0.0152 Amperes (0.182 Watts).

General DC power requirement notes.

1. Minimum current loading for each supply voltage is not less than 4% of the maximum operating current shown.
2. The +5V and +12V supplies should employ separate ground returns.
3. Where power is provided to multiple drives from a common supply, careful consideration for individual drive power requirements should be noted. Where multiple units are powered on simultaneously, the peak starting current must be available to each device.

6.2.1 Conducted noise immunity

Noise is specified as a periodic and random distribution of frequencies covering a band from DC to 10 MHz. Maximum allowed noise values given below are peak-to-peak measurements and apply at the drive connector.

	+5V	+12V (with spindle motor not running)
0 to 100 kHz	150mV	150mV
100 kHz to 10 MHz	100mV	100mV

6.2.2 Power sequencing

The drive does not require power sequencing. The drive protects against inadvertent writing during power-up and down.

6.2.3 Current profiles

Figure 3 identifies the drive +12V current profile. The current during the various times is as shown:

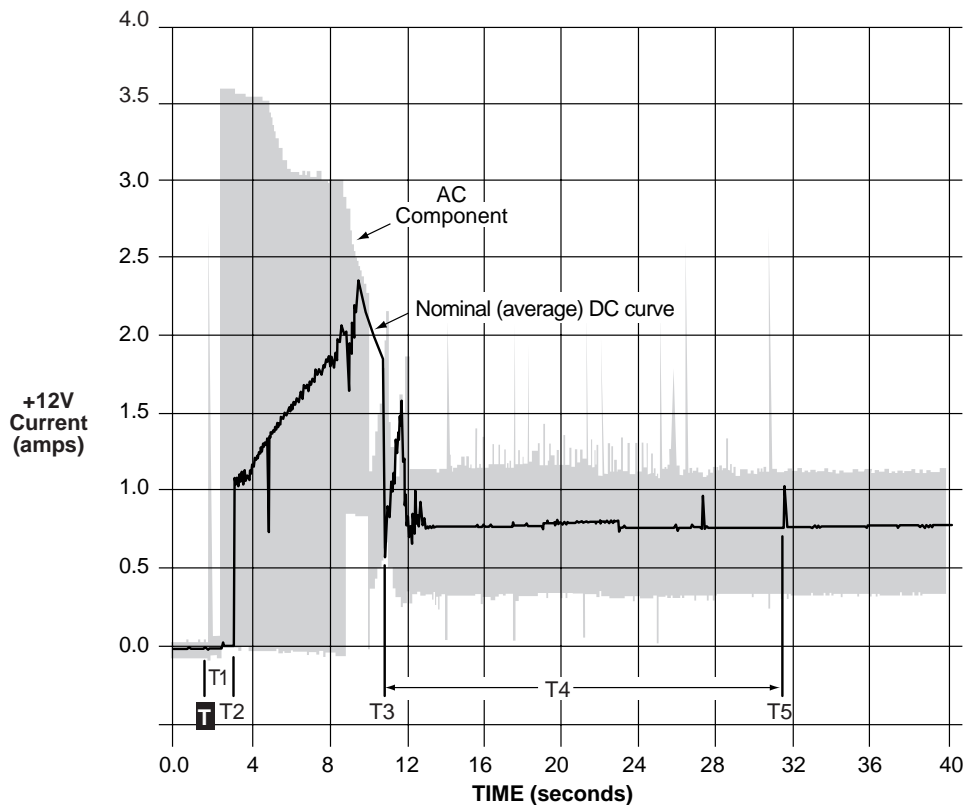

Figure 3. Typical Barracuda 18FC drive +12V current profile

- T0 Power is applied to the drive.
- T1 Controller self-tests are performed.
- T2 Spindle begins to accelerate under current limiting after performing internal diagnostics.
- T3 Spindle is up to speed and the head and arm restraint is unlocked.

Note: All times and currents are typical. See Table 1 for maximum current requirements.

6.3 Power dissipation

Typical seek power dissipation is 23.3 watts (79.4 BTUs per hour) of DC power average at nominal voltages. Typical power dissipation under idle conditions is 17.1 watts (58.4 BTUs per hour).

6.4 Environmental limits

Temperature and humidity values experienced by the drive must be such that condensation does not occur on any drive part. Altitude and atmospheric pressure specifications are referenced to a standard day at 58.7°F (14.8°C). Maximum wet bulb temperature is 82°F (28°C).

6.4.1 Temperature

a. Operating

The MTBF specification for the drive is based on operating at a local ambient temperature of 86°F (30°C). Occasional excursions to drive ambient temperatures of 122°F (50°C) or 41°F (5°C) may occur without impact to specified MTBF. The enclosure for the drive should be designed such that the PCBA and case temperatures listed in Section 8.4.1 and illustrated in Figures 8 and 9 on page 30 are not exceeded. Air flow may be needed to achieve these temperature values. Continual or sustained operation at case temperatures above these values will degrade MTBF.

The drive meets all specifications over a 41°F to 122°F (5°C to 50°C) drive ambient temperature range with a maximum gradient of 36°F (20°C) per hour when the case temperature limits specified above are not exceeded.

b. Non-operating

Non-operating temperature should remain between –40°F to 158°F (–40°C to 70°C) package ambient with a maximum gradient of 36°F (20°C) per hour. This assumes that the drive is packaged in the shipping container designed by Seagate.

6.4.2 Relative humidity

The values below assume that no condensation on the drive occurs.

a. Operating

5% to 90% relative humidity with a maximum gradient of 10% per hour.

b. Non-operating

5% to 95% relative humidity with a maximum gradient of 10% per hour.

6.4.3 Effective altitude (sea level reference)

a. Operating

–1,000 to +10,000 feet (–305 to +3,048 meters)

b. Non-operating

–1,000 to +40,000 feet (–305 to +12,210 meters)

6.4.4 Shock and vibration

Shock and vibration limits specified in this document are measured directly on the drive chassis. If the drive is installed in an enclosure to which the stated shock and/or vibration criteria are applied, resonances may occur internally to the enclosure resulting in drive movement in excess of the stated limits. If this situation is apparent, it may be necessary to modify the enclosure to minimize drive movement.

The limits of shock and vibration defined within this document are specified with the drive mounted in a vertical or horizontal position and in accordance with the restrictions of Section 8.4. Orientation of the side nearest the LED may be up or down.

6.4.4.1 Shock

a. Operating (normal)

The drive, as installed for normal operation, will operate error free while subjected to intermittent shock not exceeding 2.0 Gs at a maximum duration of 11 msec (half sinewave). Shock may be applied in the X, Y, or Z axis.

b. Operating (abnormal)

Equipment as installed for normal operation will not incur physical damage while subjected to intermittent shock not exceeding 10 Gs at a maximum duration of 11 msec (half sinewave). Shock occurring at abnor-

mal levels may promote degraded operational performance during the abnormal shock period. Specified operational performance will continue when normal operating shock levels resume. Shock may be applied in the X, Y, or Z axis. Shock is not to be repeated more than two times per second.

c. Non-operating

The limits of non-operating shock apply to all conditions of handling and transportation. This includes both isolated drives and integrated drives.

The drive subjected to non-repetitive shock not exceeding 75 Gs at a maximum duration of 11 msec (half sinewave) will not exhibit device damage or performance degradation. Shock may be applied in the X, Y, or Z axis.

The drive subjected to non-repetitive shock not exceeding 140 Gs at a maximum of 2 msec (half sinewave) will not exhibit device damage or performance degradation. Shock may be applied in the X, Y, or Z axis.

d. Packaged

Disc drives shipped as loose load (not palletized) general freight will be packaged to withstand drops from heights as defined in the table below. For additional details, refer to Seagate specifications 30190-001 (under 100 lbs/45 kg) or 30191-001 (over 100 lbs/45 kg).

Package size	Packaged/product weight	Drop height
<600 cu in (<9,800 cu cm)	Any	60 in (1,524 mm)
600 to 1,800 cu in (9,800 to 19,700 cu cm)	0 to 20 lb (0 to 9.1 kg)	48 in (1,219 mm)
>1,800 cu in (>19,700 cu cm)	0 to 20 lb (0 to 9.1 kg)	42 in (1,067 mm)
>600 cu in (>9,800 cu cm)	20 to 40 lb (9.1 to 18.1 kg)	36 in (914 mm)

6.4.4.2 Vibration

a. Operating (normal)

The drive as installed for normal operation will operate error free while subjected to continuous vibration not exceeding:

5–350 Hz @ 0.5 G

Vibration may be applied on the X, Y, or Z axis.

b. Operating (abnormal)

Equipment as installed for normal operation will not incur physical damage while subjected to periodic vibration not exceeding:

15 minutes of duration at major resonant frequency

5–400 Hz @ 0.75 G

Vibration occurring at these levels may degrade operating performance during the abnormal vibration period. Specified operating performance will continue when normal operating vibration levels are resumed. This assumes system recovery routines are available. Abnormal vibration may be applied on the X, Y, or Z axis.

c. Non-operating

The limits of non-operating vibration apply to all conditions of handling and transportation. This includes both isolated drives and integrated drives.

The drive will not incur physical damage or degraded performance as a result of continuous vibration not exceeding:

5–22 Hz @ 0.081 in. (2.05 mm) displacement

22–350 Hz @ 2.00 Gs

Vibration may be applied in the X, Y, or Z axis.

6.4.5 Air cleanliness

The drive is designed to operate in a typical office environment with minimal environmental control.

6.5 Electromagnetic susceptibility

As a component part, the drive is not required to meet any susceptibility performance requirements. It is the responsibility of the system integrator to perform tests required to ensure that equipment operating in the same system as the drive does not adversely affect the performance of the drive. See paragraph 6.2, “DC power requirements.”

6.6 Mechanical specifications

The following nominal dimensions are exclusive of the decorative front panel accessory. See Figure 4 for detailed mounting configuration dimensions for the drive. See Figure 12 on page 47 for detailed FC-AL SCA connector dimensions.

Height	1.62 in	41.1 mm
Width	4.00 in	101.6 mm
Depth	5.75 in	146.05 mm
Weight	2.1 lb	0.95 kilograms

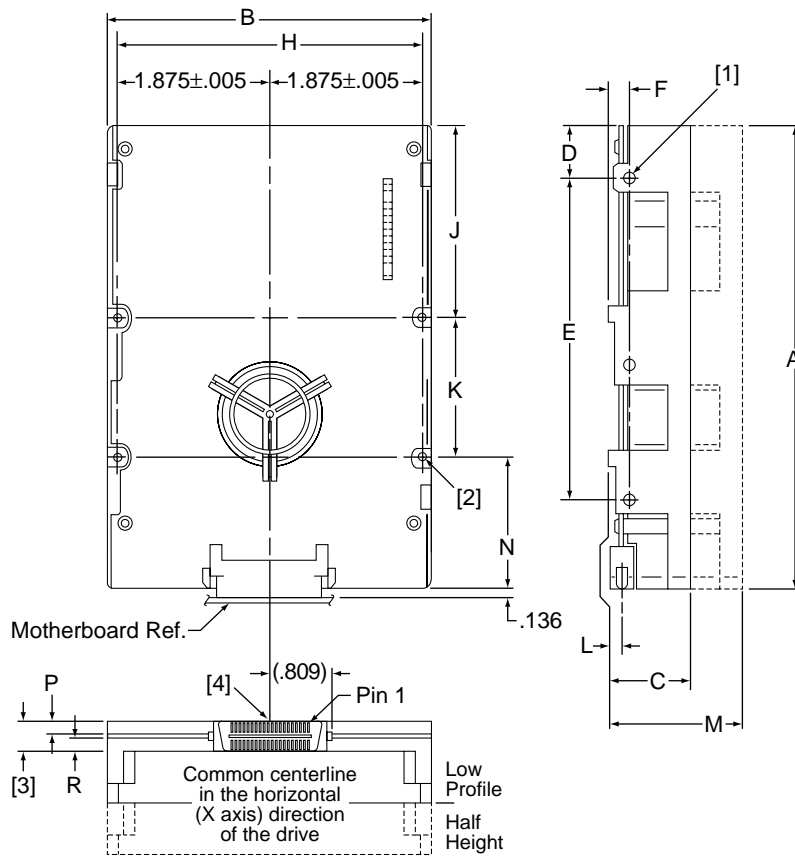

Notes:

- [1] Mounting holes three on each side, 6-32 UNC. Max screw length into side of drive is 0.15 in. (3.81 mm).
- [2] Mounting holes four on bottom, 6-32 UNC. Max screw length into bottom of drive is 0.15 in. (3.81 mm).
- [3] Keep-out zone for any components on backplane.
- [4] Connector is centered on module and flush with end of base.

	Inches	Millimeters
A	5.75 ± 0.025	146.05 ± .64
B	4.00 ± 0.015	101.6 ± .381
C	1.026 max	26.06 max
D	.620 ref	15.748 ref
E	4.000 ± 0.010	101.60 ± .25
F	.250 + 0.011 - 0.005	6.35 + .28 - .12
H	3.750 ± 0.010	95.25 ± .25
J	2.380 ± 0.010	60.45 ± .25
K	1.750 ± 0.010	44.45 ± .50
L	0.181 + 0.013 - 0.007	4.59 + .33 - .18
M	1.622 + 0.027 - 0.021	41.20 + .69 - .53
N	1.620 ± 0.025	41.15 ± .64
P	.1215 max	3.08 max
R	.1215 max	3.08 max

Figure 4. Mounting configuration dimensions

7.0 Defect and error management

The drive, as delivered, complies with this product manual. The read error rates and specified storage capacities are not dependent upon use of defect management routines by the host (initiator).

Defect and error management in the SCSI protocol involves the drive internal defect/error management and FC-AL system error considerations (errors in communications between the initiator and the drive). Tools for use in designing a defect/error management plan are briefly outlined in this section. References to other sections are provided when necessary.

7.1 Drive internal defects/errors

During the initial drive format operation at the factory, media defects are identified, tagged as being unusable, and their locations recorded on the drive primary defects list (referred to as the “P” list and also as the ETF defect list). At factory format time, these known defects are also reallocated, that is, reassigned to a new place on the medium and the location listed in the defects reallocation table. The “P” list is not altered after factory formatting. Locations of defects found and reallocated during error recovery procedures after drive shipment are listed in the “G” list (defects growth list). The “P” and “G” lists may be referenced by the initiator using the Read Defect Data command.

Details of the SCSI commands supported by the drive are described in the *Fibre Channel Interface Manual*. Also, more information on the drive error recovery philosophy is presented in the *Fibre Channel Interface Manual*.

7.2 Drive error recovery procedures

When an error occurs during drive operation, the drive, if programmed to do so, performs error recovery procedures to attempt to recover the data. The error recovery procedures used depend on the options previously set in the Error Recovery Parameters mode page. Error recovery and defect management may involve using several SCSI commands described in the *Fibre Channel Interface Manual*. The drive implements selectable error recovery time limits required in video applications.

The error recovery scheme supported by the drive provides a way to control the total error recovery time for the entire command in addition to controlling the recovery level for a single LBA. The total amount of time spent in error recovery for a command can be limited using the Recovery Time Limit bytes in the Error Recovery mode page. The total amount of time spent in error recovery for a single LBA can be limited using the Read Retry Count or Write Retry Count bytes in the Error Recovery mode page.

The drive firmware error recovery algorithms consists of 12 levels for read recoveries and five levels for write. Each level may consist of multiple steps, where a step is defined as a recovery function involving a single re-read or re-write attempt. The maximum level used by the drive in LBA recovery is determined by the read and write retry counts.

Table 2 equates the read and write retry count with the maximum possible recovery time for read and write recovery of individual LBAs. The times given do not include time taken to perform reallocations. Reallocations are performed when the ARRE bit (for reads) or AWRE bit (for writes) is one, the RC bit is zero, and the recovery time limit for the command has not yet been met. Time needed to perform reallocation is not counted against the recovery time limit.

When the RC bit is one, reallocations are disabled even if the ARRE or AWRE bits are one. The drive will still perform data recovery actions within the limits defined by the Read Retry Count, Write Retry Count, and Recovery Time Limit parameters. However, the drive does not report any unrecovered errors.

Table 2: Read and write retry count maximum recovery times

Read retry count [1]	Maximum recovery time per LBA (cumulative, msec)	Write retry count [1]	Maximum recovery time per LBA (cumulative, msec)
0	65.7	0	35.8
1	77.6	1	53.7
2	89.6	2	59.7
3	113.4	3	77.6
4	149.3	4	185.1
5	197.0	5 (default)	226.9
6	244.8		
7	334.3		
8	394.0		
9	441.8		
10	549.2		
11	2,009.2		
12 (default)	4,283.8		

- [1] Setting these retry counts to a value below the default setting could result in degradation of the unrecovered error rate. For example, suppose the read/write recovery page has the RC bit = 0, the read retry count set to 4, and the recovery time limit set to 450. A 4-block read command can take up to 149.3 msec recovery time for each block and a maximum of 450 msec recovery for all four blocks. If either of these limits is reached and a block has not yet been recovered, the command will end with Check Condition status and an unrecoverable read error will be reported.

7.3 FC-AL system errors

Information on the reporting of operational errors or faults across the interface is given in the *Fibre Channel Interface Manual*. The FCP Response returns information to the host about numerous kinds of errors or faults. The Receive Diagnostic Results reports the results of diagnostic operations performed by the drive.

Status returned by the drive to the initiator is described in the *Fibre Channel Interface Manual*. Status reporting plays a role in systems error management and its use in that respect is described in sections where the various commands are discussed.

8.0 Installation

Barracuda 18FC disc drive installation is a plug-and-play process. There are no jumpers, switches, or terminators on the drive. Simply plug the drive into the host's 40-pin Fibre Channel backpanel connector (FC-SCA)—no cables are required. See Section 9.5 for additional information about this connector.

Use the FC-AL interface to select drive ID and all option configurations for devices on the loop.

If multiple devices are on the same FC-AL and physical addresses are used, set the device selection IDs (SEL IDs) on the backpanel so that no two devices have the same selection ID. This is called the hard assigned arbitrated loop physical address (AL_PA). There are 125 AL_PAs available (see Table 21 on page 51). If you set the AL_PA on the backpanel to any value other than 0, the device plugged into the backpanel's SCA connector inherits this AL_PA. In the event you don't successfully assign unique hard addresses (and therefore have duplicate selection IDs assigned to two or more devices), the FC-AL generates a message indicating this condition. If you set the AL_PA on the backpanel to a value of 0, the system issues a unique soft-assigned physical address automatically.

Loop initialization is the process used to verify or obtain an address. The loop initialization process is performed when power is applied to the drive, when a device is added or removed from the Fibre Channel loop, or when a device times out attempting to win arbitration.

- Set all option selections in the connector prior to applying power to the drive. If you change options after applying power to the drive, recycle the drive power to activate the new settings.
- It is not necessary to low-level format this drive. The drive is shipped from the factory low-level formatted in 512-byte logical blocks. You need to reformat the drive only if you want to select a different logical block size.

8.1 Drive ID/option selection

All drive options are made through the interface connector (J1). Table 18 on page 48 provides the pin descriptions for the 40-pin Fibre Channel single connector (J1).

8.2 LED connections

A connector, J6, is provided on the printed circuit board assembly (PCBA) to provide port bypass, drive active, and drive fault LED connections (see Figure 6 on page 28). See Sections 9.5.7, 9.5.8, and 9.5.9 for descriptions of LED functions.

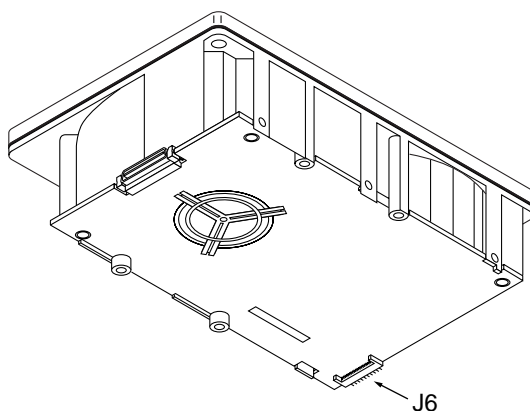
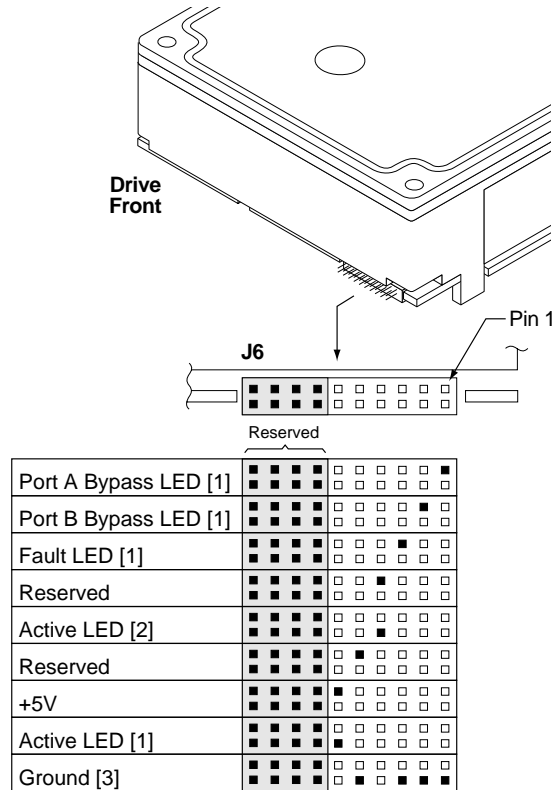

Figure 5. Physical interface



- [1] The drive has a 2.2K ohm resistor in series with this LED driver. Tie the minus side of an external high-efficiency LED (i.e., 2ma) to this pin. Connect the plus side of the LED to +5V.
- [2] An external current-limiting resistor is required when connecting an LED to this pin. The minus side of the resistor/LED combination is connected to this pin. Connect the plus side to +5V.
- [3] Jumper storage location (across pins 2 and 4).

Figure 6. LED indicator connector

8.2.1 J6 connector requirements

Recommended mating connector part number: Berg receptacle, 6-position, Berg part number 690-006.

8.3 Drive orientation

The drive may be mounted in any orientation. All drive performance characterizations, however, have been done with the drive in horizontal (discs level) and vertical (drive on its side) orientations, which are the two preferred mounting orientations.

8.4 Cooling

Cabinet cooling must be designed by the customer so that the ambient temperature immediately surrounding the drive will not exceed temperature conditions specified in Section 6.4.1, "Temperature." Specific consideration should be given to make sure adequate air circulation is present around the printed circuit board assembly (PCBA) to meet the requirements of Section 6.4.1, "Temperature."

8.4.1 Air flow

The rack, cabinet, or drawer environment for the drive must provide cooling of the electronics and head and disc assembly (HDA). You should confirm that adequate cooling is provided using the temperature measurement guidelines described below.

The drive should be oriented, or air flow directed, so that the least amount of air-flow resistance is created while providing air flow to the electronics and HDA. Also, the shortest possible path between the air inlet and exit should be chosen to minimize the travel length of air heated by the drive and other heat sources within the rack, cabinet, or drawer environment.

Possible air-flow patterns are shown in Figure 7. The air-flow patterns are created by one or more fans, either forcing or drawing air as shown in the illustrations. Other air-flow patterns are acceptable as long as the temperature measurement guidelines are met.

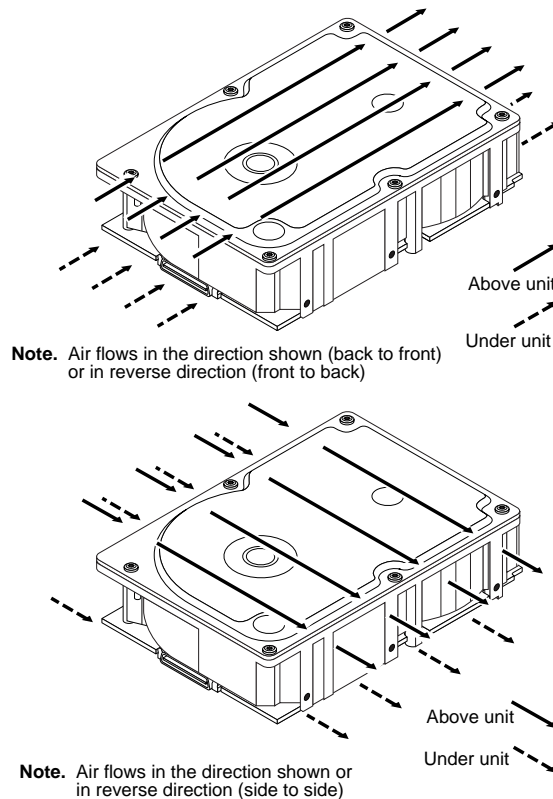

Figure 7. Air flow

To confirm that the required cooling for the electronics and HDA is provided, place the drive in its final mechanical configuration, perform random write/read operations and, after the temperatures stabilize, measure the case temperature of the components listed below. Component reference locations are shown in Figure 8. The typical ambient air temperature associated with the list is 25°C and the resulting MTBF is 1,000,000 hours.

Figure 7 shows the air flow pattern used to generate the 1,000,000 hours MTBF temperature guidelines listed below. Local average air velocities were 235 lpm (1.2 m/s) and air temperature was 77°F (25°C) plus a 5°C temperature rise in the test enclosure (30°C ambient local to the drive).

PCBA and HDA temperatures

Component	Reference	MTBF 1,000,000 hours at 30°C ambient temperature (°C)
HDA	Figure 9	45
Transceiver	1	56
Aurora	2	53
Servo DSP (Bailey)	3	48
Motor Control (Musket)	4	45
Read Chain (King Cobra)	5	48

To obtain the maximum temperature for each of the reference components listed, add 20°C to the 1,000,000 hour MTBF case temperatures. The maximum allowable HDA case temperature is 60°C (see Figure 9). Operation of the drive at the maximum case temperature is intended for short time periods only. Continuous operation at the elevated temperatures will reduce product reliability.

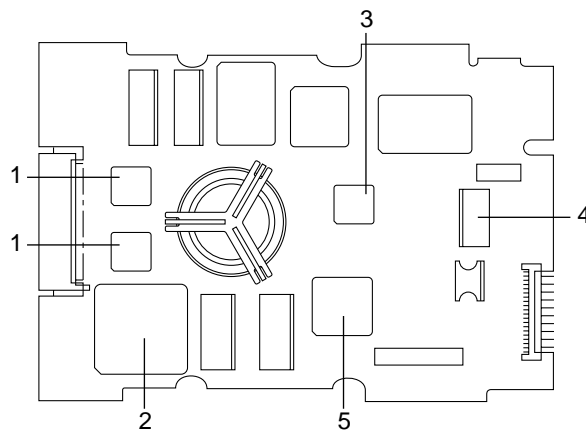

Figure 8. PCBA temperature measurement locations

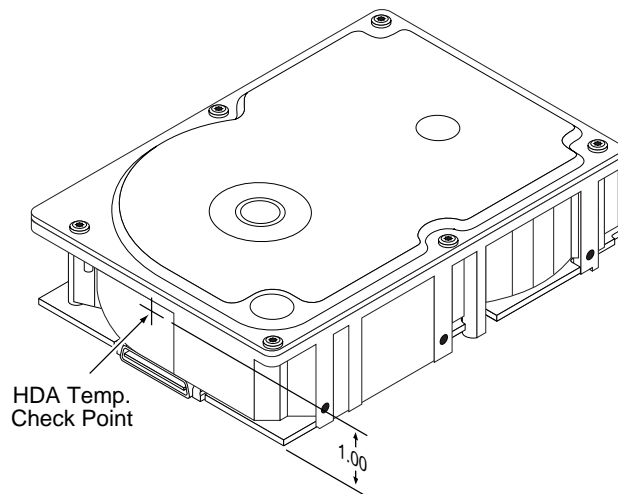

Figure 9. HDA case temperature measurement location

8.5 Drive mounting

Mount the drive using the bottom or side mounting holes. If you mount the drive using the bottom holes, ensure that you do not physically distort the drive by attempting to mount it on a stiff, non-flat surface.

The allowable mounting surface stiffness is 80 lb/in (14.0 N/mm). The following equation and paragraph define the allowable mounting surface stiffness:

$$K \times X = F \leq 15\text{lb} = 67\text{N}$$

where K is the mounting surface stiffness (units in lb/in or N/mm) and X is the out-of-plane surface distortion (units in inches or millimeters). The out-of-plane distortion (X) is determined by defining a plane with three of the four mounting points fixed and evaluating the out-of-plane deflection of the fourth mounting point when a known force (F) is applied to the fourth point.

8.6 Grounding

Signal ground (PCBA) and HDA ground are connected together in the drive and cannot be separated by the user. Maximizing the conductive contact area between HDA ground and system ground may reduce radiated emissions. If you do not want the system chassis to be connected to the HDA/PCBA ground, you must provide a nonconductive (electrically isolating) method of mounting the drive in the host equipment; however, this may increase radiated emissions and is the system designer's responsibility.

9.0 Interface requirements

This section partially describes the interface requirements as implemented on ST118273FC drives. Additional information is provided in the *Fibre Channel Interface Manual* (part number 77767496).

9.1 FC-AL features

This section lists the Fibre Channel-specific features supported by ST118273FC drives.

9.1.1 Fibre Channel link service frames

Table 3 lists the link services supported by ST118273FC drives.

Table 3: Link services supported

Type of frame	Link service
Basic link service frames	Abort Sequence (ABTS)
Basic link service reply frames	Basic_Accept (BA_ACC) Basic_Reject (BA_RJT)
Extended link service frames	N_Port Login (PLOGI) Fabric Login (FLOGI) Logout (LOGO) Process Login (PRLI) Process Logout (PRLO) Read Link Status (RLS) Port Discovery (PDISC) Address Discovery (ADISC) Third-party Process Logout (TRPLO)
Extended link service reply frames	Accept (ACC) Link Service Reject (LS_RJT)

9.1.2 Fibre Channel task management functions

Table 4 lists the Fibre Channel SCSI Fibre Channel Protocol (FC SCSI FCP) task management functions supported.

Table 4: Fibre Channel SCSI FCP task management functions

Task name	Supported
Terminate task	No
Clear ACA	Yes
Target reset	Yes
Clear task set	Yes
Abort task set	Yes

9.1.3 Fibre Channel task management responses

Table 5 lists the FC SCSI FCP response codes returned for task management functions supported.

Table 5: FC SCSI FCP response codes

Function name	Response code
Function complete	00
Function not supported	04
Function reject	05

9.1.4 Fibre Channel port login

Table 6 identifies the required content of the N_Port Login (PLOGI) payload from an initiator.

Table 6: N_Port login (PLOGI) payload

Bytes																	
0-15	03	00	00	00	09	09	BB	BB	CF	XX	FS	FS	XX	XX	XX	XX	Common
16-31	XX	XX	XX	XX	PN	PN	PN	PN	PN	PN	PN	PN	NN	NN	NN	NN	
32-35	NN	NN	NN	NN													
36-47					XX	XX	XX	XX	XX	XX	XX	XX	XX	XX	XX	XX	Class 1
48-51	XX	XX	XX	XX													
52-63					XX	XX	XX	XX	XX	XX	XX	XX	XX	XX	XX	XX	Class 2
64-67	XX	XX	XX	XX													
68-79					SO	SO	IC	IC	XX	XX	FS	FS	XX	CS	XX	XX	Class 3
80-83	OS	OS	XX	XX													
84-95					XX	XX	XX	XX	XX	XX	XX	XX	XX	XX	XX	XX	Reserved
96-99	XX	XX	XX	XX													
100-111					XX	XX	XX	XX	XX	XX	XX	XX	XX	XX	XX	XX	Vendor
112-115	XX	XX	XX	XX													Version

- X Indicates a four-bit (hex) field is not checked.
- x Indicates a single bit not checked.
- BB BB-Credit. This field is not checked. The FC-AL drive uses BB-Credit of zero (0).
- CF Common features. This binary field selects the common features requested by the initiator login.
 - MSB Continuously increasing offset Must = 1
 - Random relative offset Not checked. Port Login Accept will return a 0—not supported.
 - Valid version level x
 - N_Port/F_Port Must = 0, N_Port
 - Alternate credit model Must = 1
 - Other bits reserved xxx XX
- FS Receive buffer field size. The FS field in the common and Class 3 parameters is checked for the range 129 < FS < 2,112 and a multiple of four bytes. For multiple frame sequences, all frames but the last frame of the sequence must be this size. Only the receive buffer field size in the Class 3 parameters is used.
- PN Port name (initiator's)—saved with the login parameters. If a change of the port name/AL_PA address association is detected during a Port DIScovery, an implicit logout occurs and the initiator returns a LS_RJT.
- NN Node name. The node name is not checked or saved by the drive.
- SO Service options Class 3 only.
 - MSB Class valid Must = 1
 - Intermix x
 - Stacked connection req. xx
 - Sequential delivery x
 - Other bits reserved xxx XX
- IC Initiator control
 - MSB XID reassign xx
 - Proc Assc 10 or 11 causes the login to be rejected. Other values are accepted.
 - Other bits XXX
- CS Concurrent sequences Must be a value greater than 0.
- OS Open sequences per exchange Must be a value greater than 0.

9.1.8 Fibre Channel fabric login

Table 10 lists the fabric login payload from the drive.

Table 10: Fabric Login (FLOGI) payload

Bytes																	
0-15	04	00	00	00	09	09	00	00	08	00	08	40	00	00	00	00	Common
16-31	00	00	02	F4	20	PP	00	20	37	UI	UI	UI	02	00	00	20	
32-35	37	UI	UI	UI													
36-47					00	00	00	00	00	00	00	00	00	00	00	00	Class 1
48-51	00	00	00	00													
52-63					00	00	00	00	00	00	00	00	00	00	00	00	Class 2
64-67	00	00	00	00													
68-79					80	00	00	00	00	00	08	40	00	00	00	00	Class 3
80-83	00	00	00	00													
84-95					00	00	00	00	00	00	00	00	00	00	00	00	Reserved
96-99	00	00	00	00													
100-111					00	00	00	00	00	00	00	00	00	00	00	00	Vendor -
112-115	00	00	00	00													Version

UI Unique identifier. This 24-bit field is uniquely assigned to the drive. This same UI appears in the Port Name and Node Name fields.

PP Port identifier field.

01 FLOGI received on Port A.

02 FLOGI received on Port B.

9.1.9 Fibre Channel fabric accept login

Table 10 lists the required content of the Fabric Login Accept (ACC) payload from the fabric.

Table 11: Fabric Login Accept (ACC) payload

Bytes																	
0-15	02	00	00	00	09	09	BB	BB	CF	XX	FS	FS	R_	A_	T0	V_	Common
16-31	E_	D_	T0	V_	PN	PN	PN	PN	PN	PN	PN	PN	NN	NN	NN	NN	
32-35	NN	NN	NN	NN													
36-47					XX	XX	XX	XX	XX	XX	XX	XX	XX	XX	XX	XX	Class 1
48-51	XX	XX	XX	XX													
52-63					XX	XX	XX	XX	XX	XX	XX	XX	XX	XX	XX	XX	Class 2
64-67	XX	XX	XX	XX													
68-79					SO	SO	xx	xx	XX	XX	FS	FS	XX	xx	XX	XX	Class 3
80-83	OS	OS	XX	XX													
84-95					XX	XX	XX	XX	XX	XX	XX	XX	XX	XX	XX	XX	Reserved
96-99	XX	XX	XX	XX													
100-111					XX	XX	XX	XX	XX	XX	XX	XX	XX	XX	XX	XX	Vendor -
112-115	XX	XX	XX	XX													Version

X Indicates a four-bit (hex) field is not checked.

x Indicates a single bit is not checked.

BB BB-Credit. This field is not checked. The FC-AL drive uses BB-Credit of zero (0).

CF Common features. This binary field selects the common features requested by the fabric login.

MSB	Continuously increasing offset	x
	Random relative offset	x
	Valid version level	x
	N_Port/F_Port	Must = 1, F_Port
	Alternate credit model	Must = 1
	Other bits reserved	xxx XX

FS Receive buffer field size. The FS field in the common and Class 3 parameters is checked for the range 128 < FS < 2,112 and a multiple of four bytes. The receive buffer field size in the Class 3 parameters is used. The drive uses the lower FS of Fabric Login Accept or N_Port Login when sending frames to an initiator.

PN Port Name. The fabric port name is saved with the login parameters. If a change of the port name is detected during a FAN, an implicit logout occurs and a LS_RJT is returned to the FAB.

NN Node Name. The drive does not check or save the node name.

SO Service Options—Class 3 only.

MSB	Class valid	Must = 1
	Intermix	x
	Stacked connection req.	xx
	Sequential delivery	Must = 1
	Other bits reserved	xxx XX

9.1.10 Fibre Channel Arbitrated Loop options

Table 12 lists the FC-AL options supported by Barracuda 18FC drives.

Table 12: FC-AL options supported

Option	Supported
OPEN Half Duplex	Accepted from another device.
OPEN Full Duplex	Send to open another device. Accepted from another device.
Private Loop	Yes
Public Loop	No
Old Port State	No
Loop Position	Yes
Loop Position Report	Yes

9.2 Dual port support

ST118273FC drives have two independent FC-AL ports. These ports may be connected on independent loops or on the same loop. Port A and Port B may be connected in any order or combination.

- If both ports are connected on independent loops and hard addressing is used, the drive interface address is selected through the interface connector and both ports will seek the same loop address. If no conflict, both ports will have the same loop address.
- If both ports are connected in the same loop and hard addressing is used, at least one port will attempt taking a soft address to prevent an address conflict.

Note. When an ST118273FC drive is connected in loops with previous Seagate FC drive products:

Barracuda 4LP FC (ST32171FC, ST34371FC, and ST34571FC)
 Barracuda 9FC (ST19171FC)
 Cheetah 4LP FC (ST34501FC)
 Cheetah 9FC (ST19101FC)

the connection of Port A and B for these products must follow the requirements in their product manuals.

Subject to buffer availability, Barracuda 18FC drives support:

- Concurrent port transfers—The drive supports receiving transfers on both ports at the same time when the ports are on independent loops.
- Full duplex—The drive supports an output transfer while receiving a transfer on the same or both ports.

9.3 SCSI commands supported

Table 13 lists the SCSI commands that ST118273FC drives support.

Table 13: Supported commands

Command code	Supported	Command name
00h	Y	Test unit ready
01h	Y	Rezero unit
03h	Y	Request sense
	Y	Extended sense
	Y	Field pointer bytes
	Y	Actual retry count bytes
04h	Y	Format unit [1]
07h	Y	Reassign blocks
08h	Y	Read
0Ah	Y	Write
0Bh	Y	Seek
12h	Y	Inquiry
	Y	Vital product data page
	Y	Unit serial number page
	Y	Implemented operating def. page
	Y	Firmware numbers page
	Y	Date code page
	Y	Jumper settings page
15h	Y	Mode select (same pages as Mode Sense command shown below) [3]
16h	Y	Reserve
	N	3rd party reserved
	N	Extent reservation
17h	Y	Release
18h	N	Copy
19h	Y	Fibre Channel Control page
1Ah	Y	Mode sense
	Y	Unit attention page (00h)
	Y	Error recovery page (01h)
	Y	Disconnect/reconnect control (page 02h)
	Y	Format page (03h)
	Y	Rigid disc drive geometry page (04h)
	Y	Verify error recovery page (07h)
	Y	Caching parameters page (08h)
	Y	Control mode page (0Ah)
	Y	Power control page (1Ah)
	Y	Information exceptions control page (1Ch)
1Bh	Y	Start unit/stop unit
1Ch	Y	Receive diagnostic results
	Y	Supported diagnostics pages
	Y	Translate page

Table 13: Supported commands (*continued*)

Command code	Supported (<i>continued</i>)	Command name
	Y	Enclosure services page
1Dh	Y	Send diagnostics page
	Y	Supported diagnostics pages
	Y	Translate page
25h	Y	Read capacity
28h	Y	Read extended
	Y	Disable page out
	Y	Force unit access
	N	Relative address
2Ah	Y	Write extended
	Y	Disable page out
	Y	Force unit access
	N	Relative address
2Bh	Y	Seek extended
2Eh	Y	Write and verify
	Y	Disable page out
	Y	Byte check
	N	Relative address
2Fh	Y	Verify
	Y	Disable page out
	Y	Byte check
	N	Relative address
30h	N	Search data high
31h	N	Search data equal
32h	N	Search data low
33h	N	Set limits
34h	N	Prefetch
35h	Y	Synchronize cache
36h	N	Lock-unlock-cache
37h	Y	Read defect data
39h	N	Compare
3Ah	N	Copy and verify
3Bh	Y	Write buffer
	Y	Write combined header and data mode (0)
	Y	Write data mode (2)
	N	Download microcode mode (4)
	Y	Download microcode and save modes (5)
	N	Download microcode with offsets mode (6)
	Y	Download microcode with offsets and save mode (7)
	Y	Firmware download option [2]
3Ch	Y	Read buffer
	Y	Read combined header and data mode (0)
	Y	Read data mode (2)

Table 13: Supported commands (*continued*)

Command code	Supported (<i>continued</i>)	Command name
	Y	Read descriptor mode (3)
3Eh	Y	Read long
3Fh	Y	Write long
40h	N	Change definition
41h	Y	Write same
	N	PBdata
	N	LBdata
42-4Bh	N	Not used
4Ch	Y	Log Select
4Dh	Y	Log Sense
4E-4Fh	N	Not used
50h	N	XD write
51h	N	XP write
52h	N	XD read
53-54h	N	Not used
55h	Y	Mode Select (10) [3]
56h	Y	Reserved (10)
	Y	3rd party reserve
	N	Extent reservation
57h	Y	Released (10)
58-59h	N	Not used
5Ah	Y	Mode Sense (10) [3]
5B-5Dh	N	Not used
5Eh	Y	Persistent Reserve In
5Fh	Y	Persistent Reserve Out
60-7Fh	N	Not used
80h	N	XD write extended
81h	N	Rebuild
82h	Y	Regenerate
83-8Fh	N	Not used
C0-DFh	N	Not used
EO-FFh	N	Not used

- [1] Barracuda 18FC drives can format to any multiple of four bytes per logical block in the range 512 to 4,096 bytes.
- [2] **Warning.** Power loss during flash programming can result in firmware corruption. This usually makes the drive inoperable.
- [3] Reference Mode Sense command 1Ah for mode pages supported.

9.3.1 Inquiry data

Table 14 lists the Inquiry command data that the drive should return to the initiator per the format given in the *Fibre Channel Interface Manual*.

Table 14: Barracuda 18FC inquiry data

Bytes	Data (hex)																
0-15	00	00	**	22	8F	00	PP	02	53	45	41	47	41	54	45	20	Vendor ID
16-31	[53	54	31	31	38	32	37	33	46	43]	20	20	20	20	20	20	Product ID
32-47	R#	R#	R#	R#	S#	S#	S#	S#	S#	S#	S#	S#	00	00	00	00	
48-63	00	00	00	00	00	00	00	00	00	00	00	00	00	00	00	00	
64-79	00	00	00	00	00	00	00	00	00	00	00	00	00	00	00	00	
80-95	00	00	00	00	00	00	00	00	00	00	00	00	00	00	00	00	
96-111	00	43	6F	70	79	72	69	67	68	74	20	28	63	29	20	31*	*Copyright
112-127	39*	39*	38*	20	53	65	61	67	61	74	65	20	41	6C	6C	20	notice
128-143	72	69	67	68	74	73	20	72	65	73	65	72	76	65	64	20	

* Copyright year (changes with actual year).

** 02 = SCSI-2 implemented with some SCSI-3 features (default).

PP 50 = Inquiry data for an Inquiry command received on Port A.

70 = Inquiry data for an Inquiry command received on Port B.

R# Four ASCII digits representing the last four digits of the product firmware release number.

S# Eight ASCII digits representing the eight digits of the product serial number.

[] Bytes 16 through 25 reflect drive model.

9.3.2 Mode Sense data

The Mode Sense command provides a way for the drive to report its operating parameters to the initiator. The drive maintains four sets of mode parameters:

1. Default values

Default values are hard-coded in the drive firmware stored in flash E-PROM (nonvolatile memory) on the drive's PCBA. These default values can be changed only by downloading a complete set of new firmware into the flash E-PROM. An initiator can request and receive from the drive a list of default values and use those in a Mode Select command to set up new current and saved values, where the values are changeable.

2. Saved values

Saved values are stored on the drive's media using a Mode Select command. Only parameter values that are allowed to be changed can be changed by this method. Parameters in the saved values list that are not changeable by the Mode Select command get their values from default values storage.

When power is applied to the drive, it takes saved values from the media and stores them as current values in volatile memory. It is not possible to change the current values (or the saved values) with a Mode Select command before the drive achieves operating speed and is "ready." An attempt to do so results in a "Check Condition" status.

On drives requiring unique saved values, the required unique saved values are stored into the saved values storage location on the media prior to shipping the drive. Some drives may have unique firmware with unique default values also.

On standard OEM drives, the saved values are taken from the default values list and stored into the saved values storage location on the media prior to shipping.

3. Current values

Current values are volatile values being used by the drive to control its operation. A Mode Select command can be used to change the values identified as changeable values. Originally, current values are installed from saved or default values after a power on reset, hard reset, or Bus Device Reset message.

4. Changeable values

Changeable values form a bit mask, stored in nonvolatile memory, that dictates which of the current values and saved values can be changed by a Mode Select command. A one (1) indicates the value can be changed. A zero (0) indicates the value is not changeable. For example, in Table 15, refer to Mode page 81, in the row entitled "CHG." These are hex numbers representing the changeable values for Mode page 81. Note in columns 5 and 6 (bytes 04 and 05), there is 00h which indicates that in bytes 04 and 05 none of the bits are changeable. Note also that bytes 06, 07, 09, 10, and 11 are not changeable, because those fields are all zeros. In byte 02, hex value FF equates to the binary pattern 11111111. If there is a zero in any bit position in the field, it means that bit is not changeable. Since all of the bits in byte 02 are ones, all of these bits are changeable.

The changeable values list can only be changed by downloading new firmware into the flash E-PROM.

Note. Because there are often several different versions of drive control firmware in the total population of drives in the field, the Mode Sense values given in the following tables may not exactly match those of some drives.

The following tables list the values of the data bytes returned by the drive in response to the Mode Sense command pages for SCSI implementation (see the *Fibre Channel Interface Manual*).

Definitions:

DEF = Default value. Standard OEM drives are shipped configured this way.

CHG = Changeable bits; indicates if default value is changeable.

9.4 Miscellaneous operating features and conditions

Table 16 lists various features and conditions. A “Y” in the support column indicates the feature or condition is supported. An “N” in the support column indicates the feature or condition is not supported.

Table 16: Miscellaneous features

Supported	Feature or condition
Y	FC-AL selective reset
Y	Automatic contingent allegiance
N	Asynchronous event notification
N	Synchronized (locked) spindle operation
Y	Segmented caching
N	Zero latency read
Y	Queue tagging (up to 128 queue tags supported)
Y	Deferred error handling
Y	Parameter rounding (controlled by Round bit in Mode Select page 0)
Y	Reporting actual retry count in Extended Sense bytes 15, 16, and 17
N	Adaptive caching
Y	SMP = 1 in Mode Select command needed to save RPL and rotational offset bytes

Table 17: Miscellaneous status

Supported	Status
Y	Good
Y	Check condition
Y	Condition met/good
Y	Busy
Y	Intermediate/good
Y	Intermediate/condition met/good
Y	Reservation conflict
Y	Task set full
Y	ACA active
Y	ACA active, faulted initiator

9.5 FC-AL physical interface

Figure 10 shows the location of the J1 Fibre Channel single connection attachment (FC-SCA) and the J6 connector. Figure 12 provides the dimensions of the FC-SCA. Figure 13 provides the dimensions of the J6 connector.

Details of the physical, electrical, and logical characteristics are provided within this section. The operational aspects of Seagate's Fibre Channel drives are provided in the *Fibre Channel Interface Manual*.

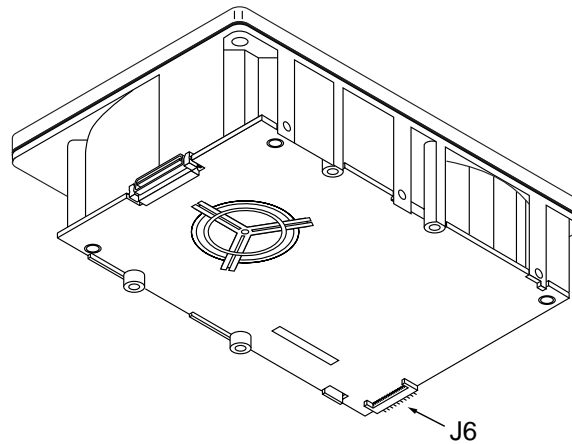

Figure 10. Physical interface

9.5.1 Physical characteristics

This section defines physical interface connector and its functions on a loop.

9.5.1.1 Physical description

Fibre Channel drives may be connected in a loop together or with other compatible FC-AL devices. A maximum of 127 devices may have addresses; however, one of the addresses is reserved for a fabric port switch device. This means 126 addresses are available for FC-AL devices. More FC-AL compatible devices may physically reside on the loop, but they will not be functional because they would not be able to obtain valid addresses.

Port bypass circuits (PBCs) allow devices to be inserted into unpopulated locations or removed from the loop with loop operation recovery after a brief interruption. These PBCs are located external to the FC-AL device. Figure 11 shows the relationship between the PBC and FC-AL device.

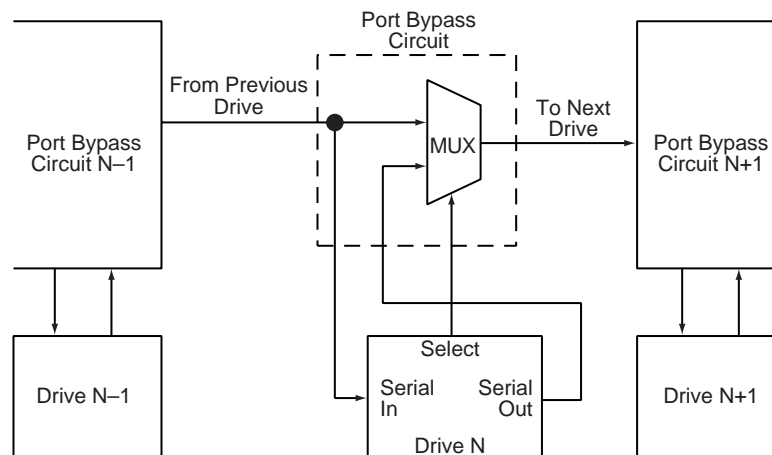

Figure 11. Port bypass circuit physical interconnect

9.5.2 Connector requirements

Recommended mating SCA part number:

Part description	Positions	Part number	Features
AMP Vertical (SCA sequence)	40	787317-1	With polarization
Berg	40	71781	With polarization
Methode	40	512-220-91-101N	With polarization
Molex	40	717431040	With polarization

The FC-AL SCA device connector is illustrated in Figure 12. The J6 connector is illustrated in Figure 13.

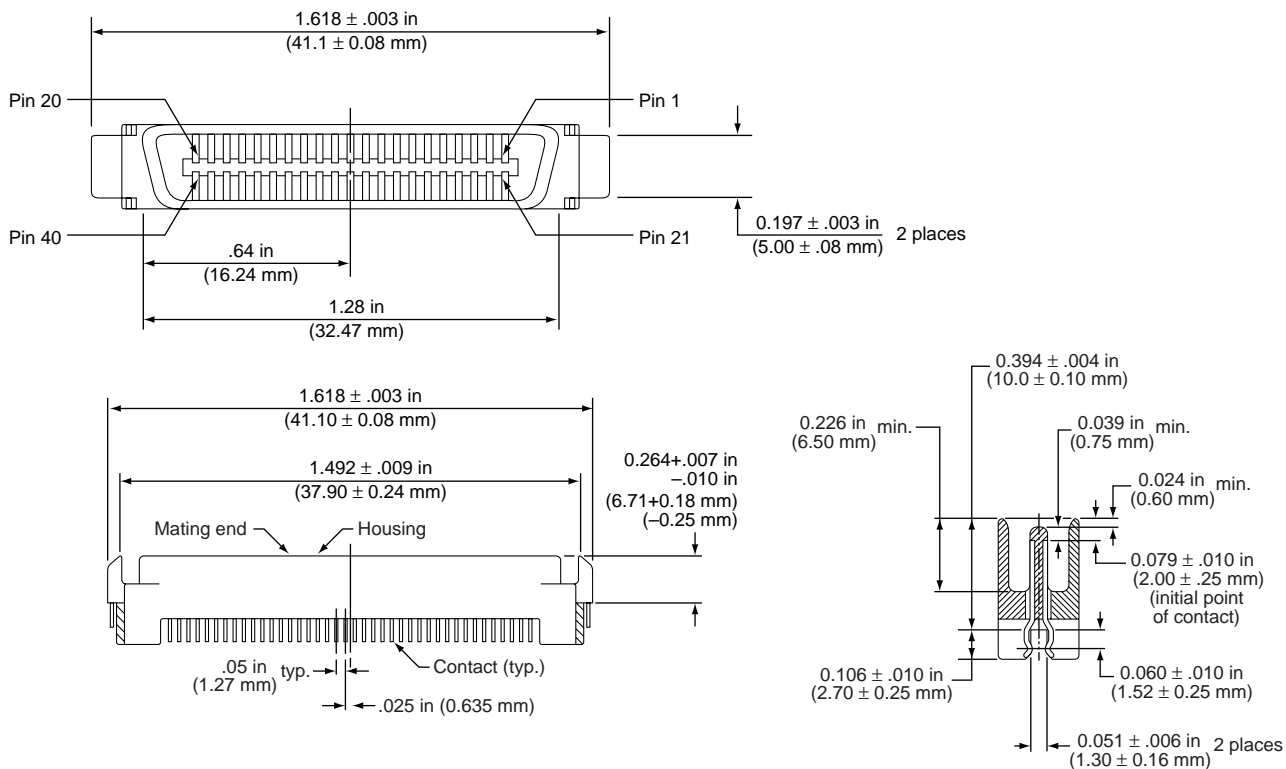

Figure 12. FC-AL SCA device connector dimensions

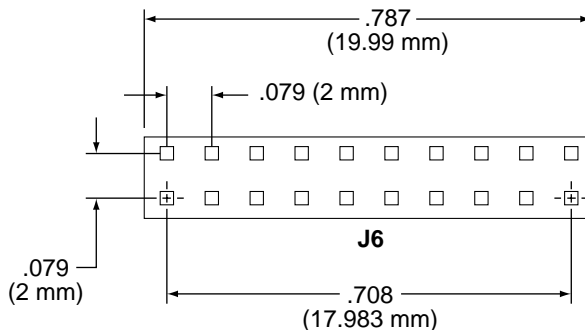

Figure 13. J6 connector dimensions

9.5.3 Electrical description

Fibre Channel drives use the FC-SCA connector for:

- DC power
- FC-AL interface
- Drive select (device identification)
- Option selection
- Enclosure Services interface

This 40-pin connector is designed to plug directly into a backpanel. External cables are not required.

9.5.4 Pin descriptions

This section provides a pin-out of the FC-SCA and a description of the functions provided by the pins.

Table 18: FC-SCA pin descriptions

Pin	Signal name	Signal type	Pin	Signal name	Signal type
1*	-EN bypass port A	TTL output	21	12 Volts charge	
2*	12 Volts		22	Ground	
3*	12 Volts		23	Ground	
4*	12 Volts		24*	+Port A_in	Diff. PECL input pair
5*	-Parallel ESI		25*	-Port A_in	
6*	Ground [1]		26	Ground	
7*	Active LED out	Open collector out	27*	+Port B_in	Diff. PECL input pair
8*	Reserved		28*	-Port B_in	
9*	Start_1	TTL input	29	Ground	
10*	Start_2	TTL input	30*	+Port A_out	Diff PECL output pair
11*	-EN bypass port B	TTL output	31*	-Port A_out	
12*	SEL_6	TTL input/output	32	Ground	
13*	SEL_5	TTL input/output	33*	+Port B_out	Diff PECL output pair
14*	SEL_4	TTL input	34*	-Port B_out	
15*	SEL_3	TTL input/output	35	Ground	
16*	Fault LED out	Open collector out	36	SEL_2	TTL input/output
17*	Reserved NC		37	SEL_1	TTL input/output
18*	Reserved NC		38	SEL_0	TTL input/output
19*	5 Volts		39	Reserved NC	
20*	5 Volts		40	5 Volts charge	

*Short pins in mating backpanel connector.

- [1] This pin may be connected to external logic to detect the presence of the drive. The drive connects this pin to the common ground.

9.5.5 FC-AL transmitters and receivers

A typical FC-AL differential copper transmitter and receiver pair is shown in Figure 14. The receiver is required to provide the AC coupling to eliminate ground shift noise.

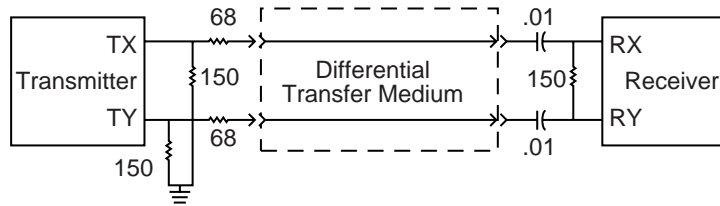

Figure 14. FC-AL transmitters and receivers

9.5.6 Power

Power is supplied through the FC-SCA with support for +5 volts and +12 volts. All of the voltage pins in the drive connector are the same length.

Four 12 volt pins provide +12 volt power to the drive. The current return for the +12 volt power supply is through the common ground pins. The maximum current typically occurs while the drive motor is starting.

Three 5 volt pins provide logic power to the drive. The current return for the +5 volt power supply is through the common ground pins. Distribute supply and return current as evenly as possible among the voltage and ground pins.

The mating connector pins use shorter contacts to achieve power surge reductions and to aid in “hot plugging” the drives. There are longer voltage contacts in the connector to enable the drive filter capacitors to charge. Current to the drive through the long charge pins is limited by the system in which the drive operates. Three of the +12 volt pins are shorter to allow capacitive pre-charging through the longer +12 volt charge pin. Two of the +5 volt pins are shorter to allow capacitive precharging through the longer +5 volt charge pin.

9.5.7 Fault LED Out

The Fault LED Out signal is driven by the drive when:

- the drive detects failure of both ports
- the drive detects an internal failure
- the drive receives the appropriate fault LED command from the host

The Fault LED Out signal is designed to pull down the cathode of an LED. The anode is attached to the proper +5 volt supply through an appropriate current-limiting resistor. The LED and the current-limiting resistor are external to the drive.

9.5.8 Active LED Out

The Active LED Out signal is driven by the drive as indicated in Table 19.

Table 19: Active LED Out conditions

Normal command activity	LED status
Spun down and no activity	Slow blink (20% on and 80% off with a 2 sec cycle)
Spun down and activity (command executing)	On
Spun up and no activity	On
Spun up and activity (command executing)	Off
Spinning up or down	Blinks steadily (50% on and 50% off)
Format in progress, each cylinder change	Toggles on/off

The Active LED Out signal is designed to pull down the cathode of an LED. The anode is attached to the proper +5 volt supply through an appropriate current limiting resistor. The LED and the current limiting resistor are external to the drive.

9.5.9 Enable port bypass signals

The – Enable Bypass Port A (– EN BYP Port A) and – Enable Bypass Port B (– EN BYP Port B) signals control the port bypass circuits (PBC) located external to the disc drive. The PBC allows a loop to remain functional in the event of a drive failure or removal. When these signals are active, low, the PBC bypasses the drive on the associated port. When an Enable Bypass signal is active, the corresponding Port Bypass LED signal in connector J1 is driven low by the disc drive. A pull down resistor, 1K, located with the PBC should be used to insure the bypass is enabled if the disc drive is not installed.

The Enable Bypass signal is active under failing conditions within the drive, on detection of the Loop Port Bypass primitive sequence, or on removal of the drive. In the bypass state the drive continues to receive on the inbound fibre. Enable Bypass may be deactivated by detection of a Loop Port Enable primitive sequence if the drive has completed self-test and a hardware failure is not present.

Failure modes detected by the disc drive that will enable bypass include:

- Transmitter/receiver wrap test failure
- Loss of receive clock
- Loss of transmission clock
- Drive interface hardware error

9.5.10 Motor start controls

The drive's motor is started according to the Start_1 and Start_2 signals described in Table 20. The state of these signals can be wired into the backplane socket or driven by logic on the backplane.

Table 20: Motor start control signals

Case	Start_2	Start_1	Motor spin function
1	Low	Low	Motor spins up at DC power on.
2	High	Low	Motor spins up only when SCSI Start command is received.
3	Low	High	Motor spins up after a delay of 12 seconds times the modulo 8 value of the numeric SEL ID of the drive from DC power on.
4	High	High	The drive will not spin up.

9.5.11 SEL_6 through SEL_0 ID lines

The SEL_6 through SEL_0 ID lines determine drive address, and, optionally, can be used for an Enclosure Services Interface (ESI). When the Parallel ESI line is high, the enclosure backpanel must provide address information on the SEL line. Refer to Table 21 for a mapping of SEL to FC-AL physical addresses (AL_PA). You can think of the SEL lines as the equivalent of a backpanel logic plug. The drives does not provide pull up resistors on these lines. The backpanel is required to provide high and low inputs to the SEL_ID lines per the specifications in Table 22 on page 52.

Note. Table 21 gives AL_PA values for each SEL value. The first entry in the table is SEL_ID 00. The last entry is SEL_ID 7D. SEL_ID 7E is AL_PA 00 which is not valid for an NL_Port, so is not included in the table. Also, SEL_ID 7Fh does map to a valid AL_PA; however this value signals the drive that physical addresses are not being assigned using the SEL lines and that a “soft” address will be determined by FC-AL loop initialization.

When the Parallel ESI line is low, the enclosure backpanel logic switches to ESI mode if supported. There are two modes of ESI, seven bits of enclosure status and a bidirectional mode. ESI support and the mode are determined by the drive using a discovery process. Refer to the *Fibre Channel Interface Manual* for a description of ESI operation.

9.5.11.1 Parallel Enclosure Services Interface (ESI)

The parallel ESI line is an output from the drive. This line provides the enclosure with an indication of the present function of the SEL lines. A high level, the default state, indicates the drive requires address information on the SEL lines. A low level indicates the drive is attempting an ESI transfer. The enclosure may not support ESI on any or all drive locations. It may only support the address function. Support of ESI is discovered by the drive. Refer to the *Fibre Channel Interface Manual* for a description of ESI operations

Table 21: Arbitrated loop physical address (AL_PA) values

AL_PA (hex)	SEL ID (hex)	Setting (dec)	AL_PA (hex)	SEL ID (hex)	Setting (dec)	AL_PA (hex)	SEL ID (hex)	Setting (dec)
EF	00	00	A3	2B	43	4D	56	86
E8	01	01	9F	2C	44	4C	57	87
E4	02	02	9E	2D	45	4B	58	88
E2	03	03	9D	2E	46	4A	59	89
E1	04	04	9B	2F	47	49	5A	90
E0	05	05	98	30	48	47	5B	91
DC	06	06	97	31	49	46	5C	92
DA	07	07	90	32	50	45	5D	93
D9	08	08	8F	33	51	43	5E	94
D6	09	09	88	34	52	3c	5F	95
D5	0A	10	84	35	53	3A	60	96
D4	0B	11	82	36	54	39	61	97
D3	0C	12	81	37	55	36	62	98
D2	0D	13	80	38	56	35	63	99
D1	0E	14	7C	39	57	34	64	100
CE	0F	15	7A	3A	58	33	65	101
CD	10	16	79	3B	59	32	66	102
CC	11	17	76	3C	60	31	67	103
CB	12	18	75	3D	61	2E	68	104
CA	13	19	74	3E	62	2D	69	105
C9	14	20	73	3F	63	2C	6A	106
C7	15	21	72	40	64	2B	6B	107
C6	16	22	71	41	65	2A	6C	108
C5	17	23	6E	42	66	29	6D	109
C3	18	24	6D	43	67	27	6E	110
BC	19	25	6C	44	68	26	6F	111
BA	1A	26	6B	45	69	25	70	112
B9	1B	27	6A	46	70	23	71	113
B6	1C	28	69	47	71	1F	72	114
B5	1D	29	67	48	72	1E	73	115
B4	1E	30	66	49	73	1D	74	116
B3	1F	31	65	4A	74	1B	75	117
B2	20	32	63	4B	75	18	76	118
B1	21	33	5C	4C	76	17	77	119
AE	22	34	5A	4D	77	10	78	120
AD	23	35	59	4E	78	0F	79	121
AC	24	36	56	4F	79	08	7A	122
AB	25	37	55	50	80	04	7B	123
AA	26	38	54	51	81	02	7C	124
A9	27	39	53	52	82	01	7D	125
A7	28	40	52	53	83			
A6	29	41	51	54	84			
A5	2A	42	4E	55	85			

9.6 Signal characteristics

This section describes the electrical signal characteristics of the drive's input and output signals. See Table 18 on page 48 for signal type and signal name information.

9.6.1 TTL characteristics

Table 22 provides the TTL characteristics.

Table 22: TTL characteristics

State	Voltage	Current
Input high	$1.9 < V_{IH} < 5.5V$	$0 < I_{IH} < \pm 500nA$ max.
Input low	$-0.5V < V_{IL} < 0.9V$	$0 < I_{IL} < \pm 500nA$ max.
Output high (-EN Bypass A, B)	$2.4 < V_{OH} < 5.25V$	$I_{OH} < -3mA$
Output low (-EN Bypass A, B)	$V_{OL} < 0.5V$	$I_{OL} < 3mA$
Output high (-Parallel ESI)	$V_{OH} > 2.4V$ $V_{OH} > 0.9V_{CC}$	$I_{OH} < -2.4mA$ $I_{OH} < -500\mu A$
Output low (-Parallel ESI)	$0 < V_{OL} < .45V$	$I_{OL} < 2.4mA$
Output high (all other outputs)	$V_{OH} > 2.4V$ $V_{OH} > 0.9V_{CC}$	$I_{OH} < -1.6mA$ $I_{OH} < -500\mu A$
Output low (all other outputs)	$0 < V_{OL} < .45V$	$I_{OL} < 1.6mA$

9.6.2 LED driver signals

Fault and Active LED signals are located in the FC-SCA connector (J1) and through the indicator connector (J6). See Table 23 for the output characteristics of the LED drive signals.

Table 23: LED drive signal

State	Current drive available	Output voltage
LED off, high	$0 < I_{OH} < 100\mu A$	
LED on, low	$I_{OL} < -30 mA$	$0 < V_{OL} < 0.4V$

9.6.3 Differential PECL output

The serial PECL output signal voltage characteristics are provided in Table 24. The outputs are not AC coupled in order to deliver maximum signal without rise and fall time degradation. You must AC couple the receiver to isolate potentially different DC characteristics of the outputs and the receiver.

Table 24: Differential PECL output characteristics

Description	Parameter	Notes
Serial output voltage swing	$300 < V_{out} < 650 mV$	Centered at 1.32V

Figure 15 provides the data output valid eye diagram relative to the bit cell time.

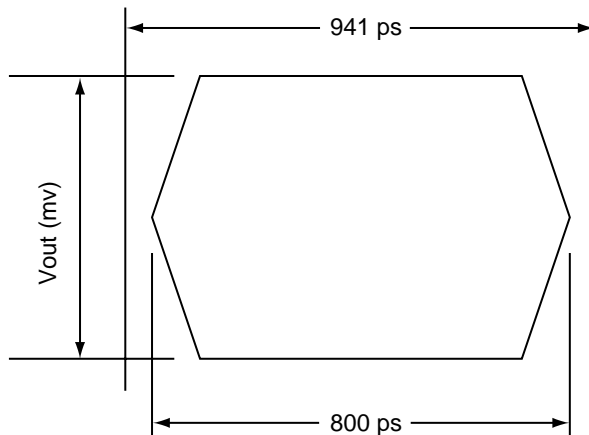

Figure 15. Transmit eye diagram

9.6.4 Differential PECL input

The serial PECL input signal voltage characteristics are provided in Table 25.

Table 25: Differential PECL input characteristics

Description	Parameter	Notes
Serial input voltage swing	$200 < V_{in} < 1.300$ mV	AC coupled

Figure 16 provides the data valid eye diagram for typical and minimum requirements to recover data at the specified interface error rate. The inputs are AC coupled on the drive.

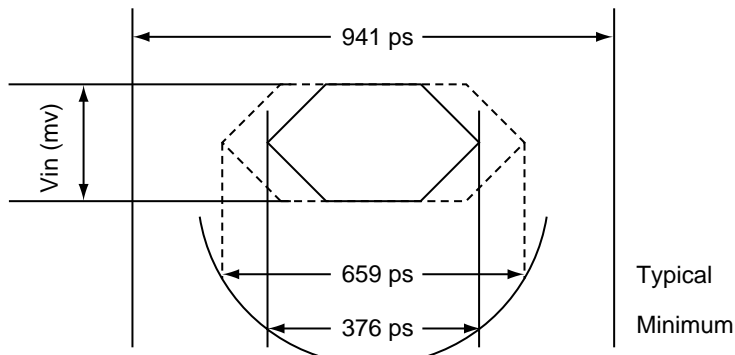

Figure 16. Receive eye diagram

10.0 Seagate Technology support services

Online Services

Internet

Visit Seagate on the Internet at <http://www.seagate.com> for online information about Seagate products. You can also send e-mail with your disc or tape questions to:

Presales: DiscPreSales@Seagate.com or Tape_Sales_Support@Seagate.com

Technical support: DiscSupport@Seagate.com or TapeSupport@Seagate.com

SeaBOARD[®] is a computer bulletin board system that contains information about Seagate disc and tape drive products and is available 24 hours daily. Set your communications software to eight data bits, no parity and one stop bit (8-N-1).

Presales Support

Our Presales Support staff can help you determine which Seagate products are best suited for your specific application or computer system.

Seagate Express

You can purchase select tape products and tape accessories through Seagate Express 24 hours daily by calling 1-800-531-0968 or by faxing your order to: 1-972-481-4812.

Automated Services

SeaFONE[®] (1-800-SEAGATE) is Seagate's 800 number (1-800-732-4283), which provides toll-free access to our automated self-help services. Here you'll find answers to commonly asked questions, troubleshooting tips and specifications for disc drives and tape drives. This service is available 24 hours daily and requires a touch-tone phone. International callers can reach this service by dialing 1-405-936-1234.

SeaFAX[®] is Seagate's automated FAX delivery system. Using a touch-tone phone, you can obtain technical support information by return FAX. This service is available 24 hours daily.

Technical Support

If you need assistance installing your drive, consult your dealer. For one-on-one help, you can talk to a technical support specialist during business hours. Before calling, note your system configuration and drive model number (STxxxx).

SeaTDD[™](1-405-936-1687) is a telecommunications device for the deaf (TDD). You can send questions or comments 24 hours daily and exchange messages with a technical support specialist from 8:00 A.M. to 12:15 P.M. and 1:30 P.M. to 6:00 P.M. (central time) Monday through Friday.

Customer Service (CSO)

Warranty Repair

Seagate direct OEM, Distribution and System Integrator customers should contact their Seagate service center representative for warranty information. Other customers should contact their place of purchase. Seagate offers comprehensive customer support for Seagate drives. These services are available worldwide.

Authorized Service Centers

If your drive is out of warranty, you can contact an Authorized Service Center for service or repair.

USA/Canada/Latin America Support Services

Presales Support

Disc: 1-877-271-3285 or 1-405-936-1210 FAX: 1-405-936-1683
Tape: 1-800-626-6637 or 1-714-641-2500 FAX: 1-714-641-2410

Technical Support (SeaFONE)

1-800-SEAGATE or 1-405-936-1234 (for specific product phone number)
 FAX: *Disc:* 1-405-936-1685; *Tape:* 1-405-936-1683

Warranty Repair

USA/Canada 1-800-468-3472 FAX: 1-405-949-6740
 Latin America 1-405-949-7758 FAX: 1-405-949-6738

SeaFAX 1-800-SEAGATE
SeaTDD 1-405-936-1687
SeaBOARD *Disc:* 1-405-936-1600; *Tape:* 1-405-936-1630

Authorized Service Centers

Brazil
MA Informatica 55-21-516-6649 FAX: 55-21-516-5280

Canada
Memofix 1-905-660-4936 FAX: 1-905-660-4951
Adtech 1-905-812-8099 or 1-800-624-9857 FAX: 1-905-812-7807

European Support Services

For European customer support, dial the toll-free number for your specific country for presales support, technical support, SeaFAX and warranty repair.

If your country is not listed here, dial our European call center at 31-20-316-7222 from 8:30 A.M. to 5:00 P.M. (European central time) Monday through Friday. The European call center is located in Amsterdam, The Netherlands.

Call Center

Austria 0 800-20 12 90
 Belgium 0 800-74 876
 Denmark 80 88 12 66
 France 0 800-90 90 52
 Germany 0 800-182 6831
 Ireland 1 800-55 21 22
 Italy 1 677 90 695
 Netherlands 0 800-732 4283
 Norway 800-113 91
 Poland 00 800-311 12 38
 Spain 900-98 31 24
 Sweden 0 207 90 073
 Switzerland 0 800-83 84 11
 Turkey 00 800-31 92 91 40
 United Kingdom 0 800-783 5177

SeaBOARD

France 33 1-48 25 35 95
 Germany 49-89-1409331
 United Kingdom 44-1628-478011

Fax Services—All European Countries

Presales/Technical Support 31-20-653-3513
 Warranty Repair 31-20-653-4320

Africa/Middle East Support Services

For presales, technical support, warranty repair and FAX services in Africa and the Middle East, dial our European call center at 31-20-316-7222 from 8:30 A.M. to 5:00 P.M. (European central time) Monday through Friday, or send a FAX to 31-20-653-4320. The European call center is located in Amsterdam, The Netherlands.

Asia/Pacific Support Services

If the customer service number for your country is not listed here, dial our Asia/Pacific headquarters located in Singapore during business hours from 9:00 A.M. to 5:00 P.M. Singapore time.

Technical Support

Australia	61-2-9725-3366	FAX: 61-2-9725-4052
Hong Kong	852-2368 9918	FAX: 852-2368 7173
Japan	—	FAX: 81-3-5462-2979
Singapore	65-488-7584	FAX: 65-488-7528
Taiwan	886-2-2514-2237	FAX: 886-2-2715-2923

SeaFAX

Australia 61-2-9756-5170

SeaBOARD

Australia	61-2-9756-2359
Taiwan	886-2-2719-6075
Thailand	662-531-8111

Warranty Repair

Japan	81-3-5462-2904	FAX: 81-3-5462-2979
Australia and other Asia/Pacific countries	65-485-3595	FAX: 65-488-7503

Index

Numerics

12 volt
 pins 49
 3rd party reserve command 41
 5 volt pins 49

A

Abort Sequence (ABTS) 33
 abort task set function 33
 AC coupling 49
 AC power requirements 19
 ACA active status 45
 ACA active, faulted initiator status 45
 Accept (ACC) 33
 active LED Out signal 49
 Actual retry count bytes command 39
 actuator 7
 assembly design 5
 adaptive caching 45
 Address Discovery (ADISC) 33
 addresses 46
 air cleanliness 22
 air flow 28
 direction 29
 illustrated 29
 pattern 29
 Alternate credit model 34, 37
 altitude limits
 non-operating 21
 operating 21
 ambient temperature 28
 ANSI documents
 fibre channel 4
 SCSI 4
 arbitrated loop 6
 arbitrated loop physical address (AL_PA) 27
 values, table of 51
 arbitration 27
 asynchronous event notification 45
 audible noise 3
 Aurora 30
 auto write and read reallocation
 programmable 6
 automatic contingent allegiance 45
 average idle current 19
 average rotational latency 9

B

backpanel 48
 backplane 50
 basic link service frames 33
 Basic_Accept (BA_ACC) 33
 Basic_Reject (BA_RJT) 33
 BB 34, 37

BB-Credit 34, 37
 buffer
 data 6
 space 11
 Bullet 30
 busy status 45
 bypass circuit 17
 Byte check command 40
 bytes per surface 9
 bytes per track 9

C

cache operation 11
 cache segments 11
 Caching parameters page (08h) command 39
 caching write data 11
 Canadian Department of Communications 3
 capacity
 formatted 7
 unformatted 7, 9
 CDB Write command (2Ah) 12
 CF 34, 37
 Change definition command 41
 character sync 17
 charge pins 49
 check condition status 45
 Class 3 parameters 34, 37
 class B limit 3
 Class valid 34, 37
 clear ACA function 33
 clear task set function 33
 commands supported 39
 Common features 34, 37
 Compare command 40
 Concurrent sequences 34
 condition met/good status 45
 connector
 illustrated 47
 requirements 47
 Continuously increasing offset 34, 37
 Control mode page (0Ah) command 39
 cooling 28, 29
 Copy and verify command 40
 Copy command 39
 CRC 17
 error 13
 CS 34
 Current profiles 20
 customer service 17
 cylinders/tracks per surface 9

D

data block size
 modifying the 7
 data buffer to/from disc media 10
 data heads
 read/write 9

- data page out (DPO) bit 12
- data rate
 - internal 9
- data transfer rate 10
- data valid eye 53
- Date code page command 39
- DC power 48
 - requirements 19
- defect and error management 25
- deferred error handling 45
- description 5
- device selection IDs 27
- devices 27
- differential PECL input 53
- dimensions
 - physical 23
- Disable page out command 40
- disc rotation speed 9
- Disconnect/reconnect control (page 02h) command 39
- Download microcode and save modes (5) 40
- Download microcode mode (4) 40
- Download microcode with offsets and save mode (7) 40
- Download microcode with offsets mode (6) 40
- drive active LED connection 27
- drive characteristics 9
- drive fault LED connection 27
- drive ID 27
- drive ID/option select headers 27
- drive mounting 31
- drive orientation 28
- drive select 48
- driver signals 52
- drivers and receivers 6
- dual port support 38
- dual port transfers 6

E

- effective altitude 21
- electrical
 - description of connector 48
 - signal characteristics 52
 - specifications 19
 - susceptibility 23
- electromagnetic compatibility 3
- electromagnetic interference (EMI) 13
- elevated temperatures 30
- EMI 13
- EMI requirements 3
- enable bypass
 - port A 50
 - port B 50
 - signal 50
 - state 17
- Enclosure services page command 39
- environmental

- interference 13
- limits 21
- requirements 13
- error
 - detection mechanisms, FC 17
 - management 25
 - rates 13
- error correction code
 - 96-bit Reed-Solomon 6
- Error recovery page (01h) command 39
- extended link service
 - frames 33
 - reply frames 33
- Extended sense command 39
- Extent reservation command 41

F

- FAB 37
- Fabric Login (FLOGI) 33
- FAN 37
- fans 29
- fault LED out signal 49
- FC-AL
 - document 4
 - interface 27, 48
 - options supported 38
 - physical interface 46
 - SCA device connector, illustrated 47
 - selective reset 45
- FCC rules and regulations 3
- FCP
 - for SCSI, document 4
 - response codes 33
 - task management functions 33
- FC-PH document 4
- features 6
 - interface 33
- Fibre Channel documents 4
- Fibre Channel Interface Manual 1, 4
- Field pointer bytes command 39
- firmware 6
 - corruption 41
- Firmware download option command 40
- Firmware numbers page command 39
- flawed logical block reallocation 6
- FLOGI
 - received on Port A 36
 - received on Port B 36
- Force unit access command 40
- form factor 6
- format 27
- Format command execution time 9
- Format page (03h) command 39
- Format unit command 39
- FS 34, 35, 37
- function
 - complete, code 00 33

not supported, code 05 33
 reject, code 04 33

G

Good status 45
 ground
 HDA 31
 signal 31
 ground shift noise 49
 grounding 31

H

hard assigned arbitrated loop physical address
 (AL_PA) 27
 head and disc assembly (HDA) 5, 28
 case temperature measurement location 30
 cooling 29
 ground 31
 heads
 read/write data 9
 hot plugging the drive 17
 humidity limits 21
 non-operating 21
 operating 21

I

IC 34
 ID and configuration options 6
 Implemented operating def. page command 39
 Information exceptions control page (1Ch) command
 39
 Initiator control 34
 Inquiry command 39
 inquiry data 42
 installation 27
 guide 4
 interface 27
 commands supported 39
 description 46
 error rate 13
 errors 13
 illustrated 46
 physical 46
 requirements 33
 interleave 6
 minimum 10
 intermediate/condition met/good status 45
 intermediate/good status 45
 Intermix 34, 37
 internal data rate 9
 internal defects/errors 25
 internal drive characteristics 9

J

J1 connector 27
 J6 connector 27, 28

Jumper settings page command 39
 jumpers 27

L

latency
 average rotational 9, 10
 LBdata 41
 LED driver signals 52
 Link Service Reject (LS_RJT) 33
 link services supported 33
 Lock-unlock-cache command 40
 Log select command 41
 Log sense command 41
 logic power 49
 logical block address 11
 logical block reallocation scheme 6
 logical block size 6, 10
 logical segments 11
 Logout (LOGO) 33
 loop 46, 50, 51
 disruption 17
 initialization 27
 loop position
 FC-AL options 38
 loop position report
 FC-AL options 38
 LS_RJT 34, 37
 LSI circuitry 7

M

maintenance 13
 maximum case temperature 30
 maximum delayed motor start 19
 maximum start current 19
 maximum temperatures 30
 mean time between failure (MTBF) 15
 mechanical specifications 23
 media description 6
 media error rate
 recoverable 13
 minimum sector interleave 10
 miscellaneous feature support
 Adaptive caching 45
 Asynchronous event notification 45
 Automatic contingent allegiance 45
 Deferred error handling 45
 FC-AL selective reset 45
 Parameter rounding 45
 Queue tagging 45
 Reporting actual retry count 45
 Segmented caching 45
 SMP = 1 in Mode Select command 45
 Synchronized (locked) spindle operation 45
 Zero latency read 45
 miscellaneous status support
 ACA active 45
 ACA active, faulted initiator 45

- Busy 45
- Check condition 45
- Condition met/good 45
- Good 45
- Intermediate/condition met/good 45
- Intermediate/good 45
- Reservation conflict 45
- Task set full 45
- miscorrected media data 13
- mode page 08h 11
- Mode select
 - (10) command 41
 - command 39
- Mode sense
 - (10) command 41
 - command 39
 - data, table 42, 44
- monitoring state 17
- motor start
 - controls 50
 - option 10
- mounting 31
 - configuration dimensions 23
 - holes 31
 - orientations 28
- MTBF 13, 15
 - defined 15

N

- N_Port Login (PLOGI) 33
 - payload 34
 - payload values 35
- NN 34, 37
- no seek complete error (02h) 13
- Node Name 37
- Node name 34
- noise
 - audible 3
- noise immunity 20

O

- old port state
 - FC-AL options 38
- OPEN Full Duplex
 - FC-AL options 38
- OPEN half duplex
 - FC-AL options 38
- Open sequences per exchange 34
- option configurations 27
- option selection 48
- options 7, 38
- OS 34
- out-of-plane distortion 31
- overhead time
 - for head switch 10
 - for one track cylinder switch 10

P

- P_LOGI
 - received on Port A 35
 - received on Port B 35
- parameter rounding 45
- pass-through state 17
- PBC 46, 50
- PBdata 41
- peak operating current 19
- peak-to-peak measurements 20
- PECL input 53
- performance characteristics
 - detailed 9
 - general 10
- performance highlights 6
- physical interface 46
 - description 46
- physical specifications 19
- PI 35, 36
- pin descriptions 48
- PN 34, 37
- port bypass circuit 17, 46, 50
- port bypass LED connection 27
- Port DIScovery 34
- Port Discovery (PDISC) 33
- port identifier field 35, 36
- port login 34
 - accept 35
- Port Name 37
- Port name (initiator's) 34
- power 49
 - dissipation 20
 - requirements, AC 19
 - requirements, DC 19
 - sequencing 20
- Power control page (1Ah) command 39
- power distribution 3
- Prefetch command 40
- prefetch/multi-segmented cache control 10
- preventive maintenance 13
- printed circuit board (PCB)
 - cooling 28
- private loop 6
 - FC-AL options 38
- Proc Assc 34
- Process Accept (ACC) 35
- Process Login (PRLI) 33, 35
- Process Login Accept (ACC) payload 35
- process login payload data 35
- Process Logout (PRLO) 33
- product reliability
 - reduction in 30
- public loop
 - FC-AL options 38
- pull down resistor 50

Q

queue tagging 45

R

radiated emissions 31
radio interference regulations 3
Random relative offset 34, 37
RCD bit 11
Read buffer command 40
Read capacity command 40
Read combined header and data mode (0) 40
Read command 39
Read data mode (2) 40
Read defect data command 40
Read descriptor mode (3) 40
Read extended command 40
Read Link Status (RLS) 33
Read long command 40
read/write data heads 9
Reassign blocks command 39
Receive buffer field size 34, 37
receive buffer field size 35
Receive diagnostic results command 39
receive eye
 diagram 53
receivers 49
recovered error (1h) 13
reference
 components 30
 documents 4
Regenerate command 41
Relative address command 40
Release command 39
Released (10) command 41
reliability 7
 and service 15
 specifications 13
repair and return information 17
reporting actual retry count 45
Request sense command 39
reservation conflict status 45
Reserve command 39
Reserved (10) command 41
return information 17
Rezero unit command 39
Rigid disc drive geometry page
 command 39
rotation speed 9
running disparity 17

S

safety 3
SCA part numbers 47
SCSI interface
 commands supported 39
SCSI Interface Product Manual 3

Search data
 equal command 40
 high command 40
 low command 40
Seek command 39
seek error
 defined 13
 rate 13
Seek extended command 40
seek performance characteristics 9
seek positioning error (15h) 13
seek time
 average typical 9
 full stroke typical 9
 single track typical 9
segmented caching 45
SEL ID 27
 lines 50
 standard feature 6
Self-Monitoring Analysis and Reporting Technology
 7, 14
Send diagnostics page command 40
Sequential delivery 34, 37
service
 life 13, 16
 philosophy 16
 tools 16
Service Options 37
Service options 34
servo
 DSP, case temperature 30
Set limits command 40
shielding 3
shipping 16
shock limits 21
 non-operating 22
 operating (abnormal) 21
 operating (normal) 21
 packaged 22
signal
 characteristics 52
 ground 31
 LED driver 52
single-unit shipping pack kit 7
SMART 7, 14
SMP = 1 in Mode Select command 45
SO 34, 37
spindle brake 6
Stacked connection req. 34, 37
standards 3
Start unit/stop unit command 39
start/stop time 10
support services 55
Supported diagnostics pages command 39, 40
surface stiffness
 allowable for non-flat surface 31
switches 27
Synchronize cache command 40

synchronized spindle
operation 45

T

target reset function 33
task management functions 33
 Abort task set 33
 Clear ACA 33
 Clear task set 33
 Target reset 33
 terminate task 33
task management response codes 33
 Function complete 00 33
 Function not supported 05 33
 Function reject 04 33
task set full status 45
technical support services 55
temperature
 limits 21
 measurement locations 30
 regulation 3
 See also cooling
Temperature measurement locations 30
terminate task function 33
terminators 27
Test unit ready command 39
Third-party Process Logout (TRPLO) 33
track follow error (09h) 13
tracks per inch 9
transceiver 30
Translate page command 39, 40
transmit eye diagram 53
transmitters 49
transporting the drive 16
troubleshooting 55
TTL characteristics 52

U

UI 35, 36
unique identifier 35, 36
Unit attention page (00h) command 39
Unit serial number page command 39
unrecoverable
 error 13
 write error, defined 13
unrecovered media data 13

V

Valid version level 34, 37
Verify command 40
Verify error recovery page (07h) command 39
vibration limits 21
 (non-operating) 22
 operating (abnormal) 22
 operating (normal) 22
Vital product data page command 39

W

warranty 16
WCE 11
word sync 17
Write and verify command 40
Write buffer command 40
write caching enable bit 11
Write combined header and data mode (0) 40
Write command 39
Write data mode (2) 40
write errors 13
Write extended command 40
Write long command 41
Write same command 41

X

XD read 41
XD write 41
XD write extended command 41
XID reassign 34
XP write 41

Z

zero latency read 45
zone bit recording (ZBR) 6



Seagate Technology, Inc.
920 Disc Drive, Scotts Valley, California 95066-4544, USA
Publication Number: 77767524, Rev. B, Printed in USA