



# Seagate® Nytro® 5060 NVMe E3.S SSD

## Product Manual

### Nytro 5560H E3.S - 3 DWPD (Mixed Use)

Capacity	ISE	SED	FIPS 140-3
<b>12800 GB</b>	XP12800LEC0006	XP12800LEC0016	XP12800LEC0026
<b>6400 GB</b>	XP6400LEC0006	XP6400LEC0016	XP6400LEC0026
<b>3200 GB</b>	XP3200LEC0006	XP3200LEC0016	XP3200LEC0026
<b>1600 GB</b>	XP1600LEC0006	XP1600LEC0016	XP1600LEC0026

### Nytro 5360H E3.S - 1 DWPD (Read Intensive)

Capacity	ISE	SED	FIPS 140-3
<b>15360 GB</b>	XP15360SEC0006	XP15360SEC0016	XP15360SEC0026
<b>7680 GB</b>	XP7680SEC0006	XP7680SEC0016	XP7680SEC0026
<b>3840 GB</b>	XP3840SEC0006	XP3840SEC0016	XP3840SEC0026
<b>1920 GB</b>	XP1920SEC0006	XP1920SEC0016	XP1920SEC0026

### Nytro 5560S E3.S - 3 DWPD (Mixed Use)

Capacity	ISE	SED	FIPS 140-3
<b>12800 GB</b>	XP12800LEC0076	XP12800LEC0046	XP12800LEC0056
<b>6400 GB</b>	XP6400LEC0076	XP6400LEC0046	XP6400LEC0056
<b>3200 GB</b>	XP3200LEC0076	XP3200LEC0046	XP3200LEC0056
<b>1600 GB</b>	XP1600LEC0076	XP1600LEC0046	XP1600LEC0056

### Nytro 5360S E3.S - 1 DWPD (Read Intensive)

Capacity	ISE	SED	FIPS 140-3
<b>15360 GB</b>	XP15360SEC0076	XP15360SEC0046	XP15360SEC0056
<b>7680 GB</b>	XP7680SEC0076	XP7680SEC0046	XP7680SEC0056
<b>3840 GB</b>	XP3840SEC0076	XP3840SEC0046	XP3840SEC0056
<b>1920 GB</b>	XP1920SEC0076	XP1920SEC0046	XP1920SEC0056

---

## Revision History

Version and Date	Description of Changes
Rev A, November 2024	Initial release of the document.

© 2024, Seagate Technology LLC All rights reserved. Publication number: 208464400, Rev A, November 2024

Seagate Technology reserves the right to make changes to the product(s) or information disclosed herein at any time without notice.

Seagate, Seagate Technology and the Spiral logo are registered trademarks of Seagate Technology LLC in the United States and/or other countries. Nytro and SeaTools are either trademarks or registered trademarks of Seagate Technology LLC or one of its affiliated companies in the United States and/or other countries. All other trademarks or registered trademarks are the property of their respective owners.

No part of this publication may be reproduced in any form without written permission of Seagate Technology LLC. Call 877-PUB-TEK1(877-782-8351) to request permission.

The NVMe word mark and/or NVMeExpress design mark are trademarks of NVMeExpress, Inc.

When referring to drive capacity, one gigabyte, or GB, equals one billion bytes and one terabyte, or TB, equals one trillion bytes. Your computer's operating system may use a different standard of measurement and report a lower capacity. In addition, some of the listed capacity is used for formatting and other functions, and thus will not be available for data storage. Actual quantities will vary based on various factors, including file size, file format, features and application software. Actual data rates may vary depending on operating environment and other factors. The export or re-export of hardware or software containing encryption may be regulated by the U.S. Department of Commerce, Bureau of Industry and Security (for more information, visit [www.bis.doc.gov](http://www.bis.doc.gov)), and controlled for import and use outside of the U.S. Seagate reserves the right to change, without notice, product offerings or specifications.

---

---

# Contents

<b>Seagate Technology Support Services</b> .....	<b>6</b>
<b>1. Introduction</b> .....	<b>7</b>
<b>2. Features</b> .....	<b>8</b>
<b>3. Nytro 5060 Models and Capacities</b> .....	<b>10</b>
<b>4. Safety, Standards, and Compliance</b> .....	<b>11</b>
4.1 Regulatory Model .....	11
<b>5. Reference Documents</b> .....	<b>12</b>
<b>6. Formatted capacities</b> .....	<b>13</b>
<b>7. Performance</b> .....	<b>14</b>
7.1 Internal drive characteristics .....	14
7.2 Performance characteristics .....	14
7.2.1 Latency .....	14
7.2.2 Performance (Throughput) .....	15
7.2.3 Quality of Service (QoS) .....	16
<b>8. Reliability specifications</b> .....	<b>18</b>
8.1 Read error rates .....	18
8.2 Endurance .....	19
8.3 Error rates .....	19
8.3.1 Unrecoverable Errors .....	19
8.3.2 Interface errors .....	20
8.4 Endurance management .....	20
8.4.1 Wear leveling .....	20
8.4.2 Garbage collection .....	20
8.4.3 Write amplification .....	20
8.4.4 Deallocation .....	20
8.4.5 Data retention .....	21
8.4.6 SSD percentage used endurance indicator .....	21
8.5 Reliability and service .....	21
8.5.1 Annualized Failure Rate (AFR) and Mean Time Between Failure (MTBF) .....	21
8.5.2 Preventive maintenance .....	21
8.5.3 Hot plugging the drive .....	21
8.5.4 SMART .....	22
8.5.5 Thermal monitor .....	22
8.5.6 Device Self Test .....	22
8.5.6.1 DST failure definition .....	23
8.5.6.2 Implementation .....	23
8.5.6.3 State of the drive prior to testing .....	23
8.5.6.4 Engage DST .....	23
8.5.6.5 Log page entries .....	23

---

8.5.6.6 Abort .....	23
8.5.7 Product warranty .....	24
8.5.8 Shipping .....	24
8.5.8.1 Product repair and return information .....	24
8.5.8.2 Storage .....	24
<b>9. Physical and electrical specifications .....</b>	<b>25</b>
9.1 Power specifications .....	25
9.1.1 Conducted noise immunity .....	25
9.2 Power consumption .....	26
9.3 Environmental limits .....	37
9.3.1 Temperature .....	37
9.3.1.1 Operating .....	37
9.3.1.2 Non-operating .....	37
9.3.2 Relative humidity .....	37
9.3.3 Effective altitude (sea level) .....	38
9.3.4 Shock and vibration .....	38
9.3.4.1 Shock .....	38
9.3.4.2 Vibration .....	39
9.3.5 Air cleanliness .....	39
9.3.6 Corrosive environment .....	39
9.4 Mechanical specifications .....	40
9.4.1 Nytro 5060 Weights .....	41
9.5 Connector specification .....	42
9.5.1 Connector specification .....	42
9.5.2 Pin descriptions .....	43
9.5.3 Power .....	44
<b>10. About FIPS .....</b>	<b>46</b>
10.1 Purpose .....	46
10.2 Validation Program .....	46
10.3 Seagate Enterprise SED .....	46
10.4 Security Level 2 .....	47
<b>11. About self-encrypting drives .....</b>	<b>48</b>
11.1 Data encryption .....	48
11.2 Controlled access .....	48
11.2.1 Admin SP .....	48
11.2.2 Locking SP .....	48
11.2.3 Default password .....	49
11.3 Random number generator (RNG) .....	49
11.4 Drive locking .....	49
11.5 Data bands .....	49
11.6 Cryptographic erase .....	50
11.7 Authenticated firmware download .....	50
11.8 Power requirements .....	50
11.9 Supported commands .....	50
11.10 Sanitize - Cryptographic Erase .....	50
11.11 RevertSP .....	51
<b>12. Installation .....</b>	<b>52</b>
12.1 Cooling .....	52
<b>13. NVMe Interface requirements .....</b>	<b>54</b>
13.1 Get/Set Features .....	54
13.2 Log Pages .....	55
13.3 Dual port support .....	55
13.4 NVMe Commands Supported .....	55

---

---

13.4.1 Identify Controller .....	57
13.4.2 Set Features Data .....	58
13.5 Signal characteristics .....	59
13.5.1 ACTIVITY# signal .....	59
13.5.2 Fault/Identity LED (Amber/Blue bi-color) .....	59

---

## Seagate Technology Support Services

For SSD Support, visit: <https://www.seagate.com/support/products/>

For Compliance data, visit: <https://www.seagate.com/support>. Scroll to the Compliance heading on left.

For Firmware Download and Tools Download for Secure Erase, visit: <https://www.seagate.com/support/downloads/>

For information regarding online support and services, visit: <http://www.seagate.com/contacts/>

For information regarding Warranty Support, visit: <http://www.seagate.com/support/warranty-and-replacements/>

For information regarding data recovery services, visit:

<http://www.seagate.com/services-software/seagate-recovery-services/recover/>

For Seagate OEM and Distribution partner and Seagate reseller portal, visit: <http://www.seagate.com/partners>

# 1. Introduction

This manual describes the Seagate® Nytro® 5060 NVMe E3.S SSD series.

The NVMe interface meets next-generation computing demands for performance, scalability, flexibility, and high-density storage requirements. Nytro 5060 NVMe SSDs are random access storage devices that support the NVMe Protocol.

The Self-Encrypting Drive Manual, describes the interface, general operation, and security features available on Self-Encrypting Drive (SED) models. See [Section 5. Reference Documents](#).

Unless otherwise stated, the information here applies to all security versions (ISE, SED, and FIPS-certified). Product data in this manual refers only to the model numbers listed in this manual.

The data in this manual may predict future generation specifications or requirements. If you are designing a system using one of the models listed or future generation products and you need further assistance, please contact the Field Applications Engineer (FAE) or our global support services group.

**NOTE** Never disassemble or try to service items in the enclosure. Opening the enclosure voids the drive warranty.

## 2. Features

Seagate Nytro 5060 NVMe E3.S SSDs have the following features.

**Table 1 - SSD Features**

Feature	Description	
<b>Capacities (User)</b>	<ul style="list-style-type: none"> <li>See <a href="#">Section 3. Nytro 5060 Models and Capacities</a></li> </ul>	
<b>Certifications, Eco-compliance</b>	<ul style="list-style-type: none"> <li>CE, FCC, UKCA, RCM, BSMI, KCC, VCCI, CB, UL, TUV, CMIM, Microsoft WHQL</li> <li>RoHS</li> </ul>	
<b>Dimensions</b>	<ul style="list-style-type: none"> <li>Max. Height: 7.65 mm / 0.30 in</li> <li>Max. Width: 76.20 mm / 3.00 in</li> <li>Max. Depth: 113.10 mm / 4.45 in</li> <li>See <a href="#">Section 9.4 Mechanical specifications</a></li> </ul>	
<b>Form Factor</b>	<ul style="list-style-type: none"> <li>E3.S 1T</li> </ul>	
<b>Weight</b>	<ul style="list-style-type: none"> <li>120g Nytro 5060 E3.S</li> <li>See <a href="#">Section 9.4.1 Nytro 5060 Weights</a></li> </ul>	
<b>Endurance</b>	<ul style="list-style-type: none"> <li>Nytro 5560: 3 DWPD</li> <li>Nytro 5360: 1 DWPD</li> <li>See <a href="#">Section 8.2 Endurance</a></li> </ul>	
<b>Interface Compliance</b>	<ul style="list-style-type: none"> <li>PCI Express Gen5 x4</li> <li>NVMe 2.0</li> <li>Single port for Nytro 5060S operation of the interface</li> <li>Dual port for Nytro 5060H operation of the two interfaces</li> </ul>	
<b>NAND</b>	<ul style="list-style-type: none"> <li>Enterprise-grade TLC, 3D</li> </ul>	
<b>Operating Systems</b>	<ul style="list-style-type: none"> <li>Windows Server 2019, Server 2022, Azure, SDDC</li> <li>Ubuntu Server 22.04, 24.04</li> <li>CentOS Stream 8, 9</li> </ul>	
<b>Performance Random</b>	<ul style="list-style-type: none"> <li>Read: Up to 3,300,000 IOPS</li> <li>Write: Up to 900,000 IOPS</li> </ul>	<p>Actual performance can vary depending on use conditions, and environment. See <a href="#">Section 7.2.2 Performance (Throughput)</a></p>
<b>Performance Sequential</b>	<ul style="list-style-type: none"> <li>Read: Up to 14,900MB/s</li> <li>Write: Up to 8600MB/s</li> </ul>	
<b>Power Consumption</b>	<ul style="list-style-type: none"> <li>Active Power, Average: &lt;23W</li> <li>Idle Power Average: 5W</li> </ul>	See <a href="#">Section 9.2 Power consumption</a>
<b>Power Management</b>	<ul style="list-style-type: none"> <li>Supports NVMe Power States</li> <li>Profiles: 25W, 22W, 20W, 18W, 15W, 12W</li> <li>Supports D3hot</li> </ul>	
<b>Security</b>	<p>Self-Encrypting Drive (SED) models comply with the Trusted Computing Group (TCG) documents:</p> <ul style="list-style-type: none"> <li>TCG Storage Architecture Core Specification, Version 2.01, Revision 2.0</li> <li>TCG Storage Security Subsystem Class Opal Specification, Version 2.02, Revision 1.0</li> </ul>	
<b>Reliability</b>	<ul style="list-style-type: none"> <li>End-to-end data path protection</li> <li>MTBF: 2.5 million hours</li> <li>UBER: 1 error in 10<sup>18</sup> bits read</li> </ul> <p>See <a href="#">Section 8.1 Read error rates</a></p>	



**Table 1 - SSD Features (continued)**

<b>Shock</b>	<ul style="list-style-type: none"> <li>■ Non-Operating: 1000 Gs at 0.5 ms</li> </ul>	See <a href="#">Section 9.3 Environmental limits</a>
<b>Vibration</b>	<ul style="list-style-type: none"> <li>■ Operating: 2.17<sub>RMS</sub>, (7 to 800Hz, Frequency)</li> </ul>	
<b>Temperature</b>	<ul style="list-style-type: none"> <li>■ Operating: 0°C to 70°C</li> <li>■ Non-operating: -40°C to 85°C</li> </ul>	
<b>Voltage</b>	<ul style="list-style-type: none"> <li>■ These drives receive DC power +12 V (Max 14V)</li> <li>■ Operation of SMBus requires application of +3.3Vaux (Max 3.63V)</li> </ul>	
<b>Warranty</b>	For warranty support details, visit: <a href="http://www.seagate.com/support/warranty-and-replacements/">http://www.seagate.com/support/warranty-and-replacements/</a> Limited Warranty with Media Usage - based on the shorter of term and endurance use of the drive.	
<b>Additional Features</b>		
<b>Nytrio 5060 Standard ISE Drives</b>		
<p>All of the following NVMe features:</p> <ul style="list-style-type: none"> <li>■ 264 I/O queue pairs per PCIe port, 528 total</li> <li>■ 64,000 maximum entries per queue</li> <li>■ Up to 128 namespaces supported</li> <li>■ PRP and SGL data transfer schemes</li> <li>■ Weighted Command Arbitration scheme support</li> <li>■ User-selectable logical block size (512, 520, 4096, 4104, or 4160 bytes per logical block)</li> <li>■ No preventive maintenance or adjustments required</li> <li>■ Self diagnostics performed when power is applied to the drive</li> <li>■ ECC and Micro-RAID Error Recovery</li> <li>■ Vertical, horizontal, or top down mounting</li> <li>■ Device Self Test (DST)</li> <li>■ Power loss data protection</li> <li>■ Authenticated firmware download</li> <li>■ Sanitize Block Erase support</li> <li>■ Sanitize Cryptographic Erase support</li> </ul>		
<b>Nytrio 5060 SED and FIPS 140-3 Drives</b>		
<p>All of the above NVMe features and the following additional features</p> <ul style="list-style-type: none"> <li>■ Automatic data encryption/decryption</li> <li>■ Controlled access</li> <li>■ TCG Opal</li> <li>■ Random number generator</li> <li>■ Drive locking</li> <li>■ Up to 8 independent locking bands plus one global band</li> </ul>		

### 3. Nytro 5060 Models and Capacities

The following categories apply to the Nytro 5060 series. Nytro 5360 and Nytro 5560 are families in the Nytro 5060 series.

**Table 2 - Nytro 5060 Models and Capacities**

<b>Nytro 5560H E3.S - 3 DWPD (Mixed Use)</b>			
<b>Capacity</b>	<b>ISE</b>	<b>SED</b>	<b>FIPS 140-3</b>
<b>12800 GB</b>	XP12800LEC0006	XP12800LEC0016	XP12800LEC0026
<b>6400 GB</b>	XP6400LEC0006	XP6400LEC0016	XP6400LEC0026
<b>3200 GB</b>	XP3200LEC0006	XP3200LEC0016	XP3200LEC0026
<b>1600 GB</b>	XP1600LEC0006	XP1600LEC0016	XP1600LEC0026
<b>Nytro 5360H E3.S - 1 DWPD (Read Intensive)</b>			
<b>Capacity</b>	<b>ISE</b>	<b>SED</b>	<b>FIPS 140-3</b>
<b>15360 GB</b>	XP15360SEC0006	XP15360SEC0016	XP15360SEC0026
<b>7680 GB</b>	XP7680SEC0006	XP7680SEC0016	XP7680SEC0026
<b>3840 GB</b>	XP3840SEC0006	XP3840SEC0016	XP3840SEC0026
<b>1920 GB</b>	XP1920SEC0006	XP1920SEC0016	XP1920SEC0026
<b>Nytro 5560S E3.S - 3 DWPD (Mixed Use)</b>			
<b>Capacity</b>	<b>ISE</b>	<b>SED</b>	<b>FIPS 140-3</b>
<b>12800 GB</b>	XP12800LEC0076	XP12800LEC0046	XP12800LEC0056
<b>6400 GB</b>	XP6400LEC0076	XP6400LEC0046	XP6400LEC0056
<b>3200 GB</b>	XP3200LEC0076	XP3200LEC0046	XP3200LEC0056
<b>1600 GB</b>	XP1600LEC0076	XP1600LEC0046	XP1600LEC0056
<b>Nytro 5360S E3.S - 1 DWPD (Read Intensive)</b>			
<b>Capacity</b>	<b>ISE</b>	<b>SED</b>	<b>FIPS 140-3</b>
<b>15360 GB</b>	XP15360SEC0076	XP15360SEC0046	XP15360SEC0056
<b>7680 GB</b>	XP7680SEC0076	XP7680SEC0046	XP7680SEC0056
<b>3840 GB</b>	XP3840SEC0076	XP3840SEC0046	XP3840SEC0056
<b>1920 GB</b>	XP1920SEC0076	XP1920SEC0046	XP1920SEC0056

#### NOTES

- Nytro 5060 SED models provide for "Security of Data at Rest" as defined by the Trusted Computing Group (see <http://www.trustedcomputinggroup.org>).
- For more on FIPS140-3 Level 2 certification see [Section 10. About FIPS](#).
- For product certification status visit <https://csrc.nist.gov/projects/cryptographic-module-validation-program/validated-modules/se arch>.

## 4. Safety, Standards, and Compliance

Each Hard Drive and Solid State Drive ("device") has a product label that includes certifications that apply to that specific drive. The following information provides an overview of requirements that may apply to the drive.

**NOTE**

***The most up to date information on Safety, Standards, and Compliance for this product is available in the Seagate HDD and SSD Regulatory Compliance and Safety document. You can find this document on the Seagate Support page here: <https://www.seagate.com/support/>***

### 4.1 Regulatory Model

The following regulatory model number represents all features and configurations in this series:

- STA044

## 5. Reference Documents

In case of conflict between this document and the following reference documents, this document takes precedence.

### SNIA documents

SFF-8489	Serial GPIO IBPI
SFF-TA-1002	Protocol Agnostic Multi-Lane High Speed Connector
SFF-TA-1009	Enterprise and Datacenter Standard Form Factor Pin and Signal Specification
SFF-TA-1008	Enterprise and Datacenter Standard Form Factor (E3)
SFF-8447	LBA Count for Disk Drives

### PCI SIG documents

PCI Express Base Specification Revision 5.0

### NVM Express documents

NVM Express Base Specification Revision 2.0  
NVM Express Management Interface Revision 1.2

### Miscellaneous documents

System Management Bus Specification Version 3.1  
I2C Bus Revision 6

### Trusted Computing Group (TCG) Documents (apply to Self-Encrypting Drive models only)

TCG Storage Architecture Core Specification Version 2.01, Revision 1.0  
TCG Storage Security Subsystem Class Opal Specification Version 2.01, Revision 1.0

### Self-Encrypting Drives Manual

Seagate part number: 100515636

## 6. Formatted capacities

Nytro 5060 models are formatted to 512 bytes per block at time of manufacturing. The block size is user-selectable at format time. Supported block sizes are 512, 520, 4096, 4104, and 4160. To obtain different formatted capacities from those listed, users who have the necessary equipment to modify data block size can do so before issuing the format command.

Nytro 5060 models follow the SFF-8447 specification.

**Table 3 - Formatted Capacity Block Count (15,360GB, 12,800GB, 7680GB, 6400GB models)**

Last Logical Block Address								
Block	15,360GB		12,800GB		7680GB		6400GB	
Size	Decimal	Hex	Decimal	Hex	Decimal	Hex	Decimal	Hex
512	30,001,856,511	6FC3FFFFFF	25,000,148,991	5D21FFFFFF	15,002,931,887	37E3E92AF	12,502,446,767	2E93432AF
520	29,391,585,279	6D7DFFFFFF	24,490,541,055	5B3BFFFFFF	15,002,931,887	37E3E92AF	12,502,446,767	2E93432AF
4096	3,750,232,063	DF87FFFF	3,125,018,623	BA43FFFF	1,875,366,485	6FC7D255	1,562,805,845	5D268655
4104	3,724,017,663	DDF7FFFF	3,103,260,671	B8F7FFFF	1,875,366,485	6FC7D255	1,562,805,845	5D268655
4160	3,673,948,159	DAFBFFFF	3,061,317,631	B677FFFF	1,875,366,485	6FC7D255	1,562,805,845	5D268655

**Table 4 - Formatted Capacity Block Count (3840GB, 3200GB, 1920GB, 1600GB models)**

Last Logical Block Address								
Block	3840GB		3200GB		1920GB		1600GB	
Size	Decimal	Hex	Decimal	Hex	Decimal	Hex	Decimal	Hex
512	7,501,476,527	1BF1F72AF	6,251,233,967	1749A42AF	3,750,748,847	DF8FE2AF	3,125,627,567	BA4D4AAF
520	7,501,476,527	1BF1F72AF	6,251,233,967	1749A42AF	3,750,748,847	DF8FE2AF	3,125,627,567	BA4D4AAF
4096	937,684,565	37E3EE55	781,404,245	2E934855	468,843,605	1BF1FC55	390,703,445	1749A955
4104	937,684,565	37E3EE55	781,404,245	2E934855	468,843,605	1BF1FC55	390,703,445	1749A955
4160	937,684,565	37E3EE55	781,404,245	2E934855	468,843,605	1BF1FC55	390,703,445	1749A955

## 7. Performance

This section provides detailed information on performance-related features of Nytro 5060 SSDs.

### 7.1 Internal drive characteristics

Flash Memory Type	eTLC 3D NAND
Emulated LBA Size	512B, 520B, 4096B, 4104B, or 4160B
Native Programmable Page Size	16KB
Map Unit Size	4096B

### 7.2 Performance characteristics

#### 7.2.1 Latency

Table 5 Nytro 5060H Latency

Latency of 5560H (3 DWPD)				
ISE	XP12800LEC0006	XP6400LEC0006	XP3200LEC0006	XP1600LEC0006
SED	XP12800LEC0016	XP6400LEC0016	XP3200LEC0016	XP1600LEC0016
SED FIPS 140-3	XP12800LEC0026	XP6400LEC0026	XP3200LEC0026	XP1600LEC0026
Sustained Random 4KB Read, QD=1, Workers=1 (μs)	60	60	60	60
Sustained Random 4KB Write, QD=1, Workers=1 (μs)	10	10	10	10
Latency of 5360H (1 DWPD)				
ISE	XP15360SEC0006	XP7680SEC0006	XP3840SEC0006	XP1920SEC0006
SED	XP15360SEC0016	XP7680SEC0016	XP3840SEC0016	XP1920SEC0016
SED FIPS 140-3	XP15360SEC0026	XP7680SEC0026	XP3840SEC0026	XP1920SEC0026
Sustained Random 4KB Read, QD=1, Workers=1 (μs)	60	60	60	60
Sustained Random 4KB Write, QD=1, Workers=1 (μs)	10	10	10	10

Table 6 Nytro 5060S Latency

Latency of 5560S (3 DWPD)				
ISE	XP12800LEC0076	XP6400LEC0076	XP3200LEC0076	XP1600LEC0076
SED	XP12800LEC0046	XP6400LEC0046	XP3200LEC0046	XP1600LEC0046
SED FIPS 140-3	XP12800LEC0056	XP6400LEC0056	XP3200LEC0056	XP1600LEC0056
Sustained Random 4KB Read, QD=1, Workers=1 (μs)	60	60	60	60
Sustained Random 4KB Write, QD=1, Workers=1 (μs)	10	10	10	10
Latency of 5360S (1 DWPD)				
ISE	XP15360SEC0076	XP7680SEC0076	XP3840SEC0076	XP1920SEC0076
SED	XP15360SEC0046	XP7680SEC0046	XP3840SEC0046	XP1920SEC0046

**Table 6 Nytro 5060S Latency (continued)**

<b>SED FIPS 140-3</b>	XP15360SEC0056	XP7680SEC0056	XP3840SEC0056	XP1920SEC0056
<b>Sustained Random 4KB Read, QD=1, Workers=1 (μs)</b>	60	60	60	60
<b>Sustained Random 4KB Write, QD=1, Workers=1 (μs)</b>	10	10	10	10

**NOTES**

These drives provide the highest possible performance under typical conditions. However, due to the nature of Flash memory technologies, many factors can result in values other than those stated here.

**7.2.2 Performance (Throughput)**

The values below indicate throughput performance for models in the Nytro 5060 series. Values are listed by product family and configuration.

**Table 7 Nytro 5060H Performance**

<b>Performance of Nytro 5560H (3 DWPD)</b>	<b>12,800GB</b>	<b>6400GB</b>	<b>3200GB</b>	<b>1600GB</b>
<b>ISE</b>	XP12800LEC0006	XP6400LEC0006	XP3200LEC0006	XP1600LEC0006
<b>SED</b>	XP12800LEC0016	XP6400LEC0016	XP3200LEC0016	XP1600LEC0016
<b>SED FIPS 140-3</b>	XP12800LEC0026	XP6400LEC0026	XP3200LEC0026	XP1600LEC0026
<b>Sustained Sequential 128KB Read (MB/s)</b>	14,800	14,900	14,900	14,900
<b>Sustained Sequential 128KB Write (MB/s)</b>	8,450	8,600	8,500	4,300
<b>Sustained Random 4KB Read (IOPS)</b>	2,600,000	3,200,000	3,300,000	2,400,000
<b>Sustained Random 4KB Write (IOPS)</b>	900,000	900,000	850,000	450,000
<b>Performance of Nytro 5360H (1 DWPD)</b>	<b>15,360GB</b>	<b>7680GB</b>	<b>3840GB</b>	<b>1920GB</b>
<b>ISE</b>	XP15360SEC0006	XP7680SEC0006	XP3840SEC0006	XP1920SEC0006
<b>SED</b>	XP15360SEC0016	XP7680SEC0016	XP3840SEC0016	XP1920SEC0016
<b>SED FIPS 140-3</b>	XP15360SEC0026	XP7680SEC0026	XP3840SEC0026	XP1920SEC0026
<b>Sustained Sequential 128KB Read (MB/s)</b>	14,800	14,900	14,900	14,900
<b>Sustained Sequential 128KB Write (MB/s)</b>	8,450	8,600	8,500	4,300
<b>Sustained Random 4KB Read (IOPS)</b>	2,600,000	3,200,000	3,300,000	2,400,000
<b>Sustained Random 4KB Write (IOPS)</b>	450,000	500,000	350,000	180,000

**Table 8 Nytro 5060S Performance**

<b>Performance of Nytro 5560S (3 DWPD)</b>	<b>12,800GB</b>	<b>6400GB</b>	<b>3200GB</b>	<b>1600GB</b>
<b>ISE</b>	XP12800LEC0076	XP6400LEC0076	XP3200LEC0076	XP1600LEC0076
<b>SED</b>	XP12800LEC0046	XP6400LEC0046	XP3200LEC0046	XP1600LEC0046
<b>SED FIPS 140-3</b>	XP12800LEC0056	XP6400LEC0056	XP3200LEC0056	XP1600LEC0056
<b>Sustained Sequential 128KB Read (MB/s)</b>	14,800	14,900	14,900	14,900
<b>Sustained Sequential 128KB Write (MB/s)</b>	8,450	8,600	8,500	4,300
<b>Sustained Random 4KB Read (IOPS)</b>	2,600,000	3,200,000	3,300,000	2,400,000
<b>Sustained Random 4KB Write (IOPS)</b>	900,000	900,000	850,000	450,000
<b>Performance of Nytro 5360S (1 DWPD)</b>	<b>15,360GB</b>	<b>7680GB</b>	<b>3840GB</b>	<b>1920GB</b>
<b>ISE</b>	XP15360SEC0076	XP7680SEC0076	XP3840SEC0076	XP1920SEC0076
<b>SED</b>	XP15360SEC0046	XP7680SEC0046	XP3840SEC0046	XP1920SEC0046

**Table 8 Nytro 5060S Performance (continued)**

<b>SED FIPS 140-3</b>	XP15360SEC0056	XP7680SEC0056	XP3840SEC0056	XP1920SEC0056
<b>Sustained Sequential 128KB Read (MB/s)</b>	14,800	14,900	14,900	14,900
<b>Sustained Sequential 128KB Write (MB/s)</b>	8,450	8,600	8,500	4,300
<b>Sustained Random 4KB Read (IOPS)</b>	2,600,000	3,200,000	3,300,000	2,400,000
<b>Sustained Random 4KB Write (IOPS)</b>	450,000	500,000	350,000	180,000

**NOTES**

- Power limit unconstrained. Maximum sustained performance measured with FIO on Linux-based OS.
- Sequential testing performed at Queue Depth = 32 after Sequential Preconditioning.
- Random testing performed at Queue Depth = 128 and Workers = 8 after Random Preconditioning.

Flash technology can produce results that differ from Seagate testing. Bandwidth limitations in the host adapter, operating system, driver limitations, and other factors can cause discrepancies. When evaluating performance of SSD devices, it is recommended to measure performance of the device in a way that resembles the targeted application using real-world data and workloads. Test time should also be large enough to make sure sustainable metrics and measures are obtained.

**7.2.3 Quality of Service (QoS)****Table 9 Nytro 5060H Quality of Service (QoS)**

<b>QoS of 5560H (3 DWPD)</b>				
<b>ISE</b>	XP12800LEC0006	XP6400LEC0006	XP3200LEC0006	XP1600LEC0006
<b>SED</b>	XP12800LEC0016	XP6400LEC0016	XP3200LEC0016	XP1600LEC0016
<b>SED FIPS 140-3</b>	XP12800LEC0026	XP6400LEC0026	XP3200LEC0026	XP1600LEC0026
<b>QoS 99% - 4KB Random Read, QD=1, Workers=1 (µs)</b>	80	80	80	80
<b>QoS 99% - 4KB Random Write, QD=1, Workers=1 (µs)</b>	12	12	12	12
<b>QoS 99% - 4KB Random Read, QD=4, Workers=8 (µs)</b>	120	120	130	140
<b>QoS 99% - 4KB Random Write, QD=4, Workers=8 (µs)</b>	80	100	130	130
<b>QoS of 5360H (1 DWPD)</b>				
<b>ISE</b>	XP15360SEC0006	XP7680SEC0006	XP3840SEC0006	XP1920SEC0006
<b>SED</b>	XP15360SEC0016	XP7680SEC0016	XP3840SEC0016	XP1920SEC0016
<b>SED FIPS 140-3</b>	XP15360SEC0026	XP7680SEC0026	XP3840SEC0026	XP1920SEC0026
<b>QoS 99% - 4KB Random Read, QD=1, Workers=1 (µs)</b>	80	80	80	80
<b>QoS 99% - 4KB Random Write, QD=1, Workers=1 (µs)</b>	12	12	12	12
<b>QoS 99% - 4KB Random Read, QD=4, Workers=8 (µs)</b>	120	120	130	140
<b>QoS 99% - 4KB Random Write, QD=4, Workers=8 (µs)</b>	100	160	160	250



**Table 10 Nytro 5060S Quality of Service (QoS)**

<b>QoS of 5560S (3 DWPD)</b>				
<b>ISE</b>	XP12800LEC0076	XP6400LEC0076	XP3200LEC0076	XP1600LEC0076
<b>SED</b>	XP12800LEC0046	XP6400LEC0046	XP3200LEC0046	XP1600LEC0046
<b>SED FIPS 140-3</b>	XP12800LEC0056	XP6400LEC0056	XP3200LEC0056	XP1600LEC0056
<b>QoS 99% - 4KB Random Read, QD=1, Workers=1 (µs)</b>	80	80	80	80
<b>QoS 99% - 4KB Random Write, QD=1, Workers=1 (µs)</b>	12	12	12	12
<b>QoS 99% - 4KB Random Read, QD=4, Workers=8 (µs)</b>	120	120	130	140
<b>QoS 99% - 4KB Random Write, QD=4, Workers=8 (µs)</b>	80	100	130	130
<b>QoS of 5360S (1 DWPD)</b>				
<b>ISE</b>	XP15360SEC0076	XP7680SEC0076	XP3840SEC0076	XP1920SEC0076
<b>SED</b>	XP15360SEC0046	XP7680SEC0046	XP3840SEC0046	XP1920SEC0046
<b>SED FIPS 140-3</b>	XP15360SEC0056	XP7680SEC0056	XP3840SEC0056	XP1920SEC0056
<b>QoS 99% - 4KB Random Read, QD=1, Workers=1 (µs)</b>	80	80	80	80
<b>QoS 99% - 4KB Random Write, QD=1, Workers=1 (µs)</b>	12	12	12	12
<b>QoS 99% - 4KB Random Read, QD=4, Workers=8 (µs)</b>	120	120	130	140
<b>QoS 99% - 4KB Random Write, QD=4, Workers=8 (µs)</b>	100	160	160	250

**NOTES**

These drives provide the highest possible performance under typical conditions. However, due to the nature of Flash memory technologies, many factors can result in values other than those stated here.

## 8. Reliability specifications

These reliability specifications assume correct host and drive operational interface, including all interface timings, power supply voltages, environmental requirements, and drive mounting constraints.

### 8.1 Read error rates

Table 11 Read Error Rates

	Error Rates	Notes
<b>Unrecovered Data</b>	Less than 1 LBA in $10^{18}$ bits transferred	
<b>Miscorrected Data</b>	Less than 1 LBA in $10^{21}$ bits transferred	
<b>Interface Error Rate</b>	Less than 1 error in $10^{12}$ bits transferred	
<b>Mean Time Between Failure (MTBF)</b>	2.5M hours	
<b>Annualized Failure Rate (AFR)</b>	0.35%	
<b>Preventive Maintenance</b>	None required	
<b>Typical Data Retention with Power removed (at 40C up to 90% of write endurance)</b>	3 months	<ul style="list-style-type: none"> <li>As NAND Flash devices age with use, the capability of the media to retain a programmed value begins to deteriorate. This deterioration is affected by the number of times a particular memory cell is programmed and subsequently erased. With use the retention capability of the device is reduced. Temperature also has an effect on how long a Flash component can retain its programmed value with power removed. At high temperature the retention capabilities of the device are reduced. Data retention is not an issue with power applied to the SSD. The SSD drive contains firmware and hardware features that can monitor and refresh memory cells when power is applied.</li> </ul>
<b>Endurance Rating</b>	Method 2: TBW (per JEDEC JESD218)	<ul style="list-style-type: none"> <li>Endurance rating is the amount of host data that can be written to the drive at the specified workload, operating temperature, and storage temperature for the life of a specific drive. For more information on the specific workload to achieve this level of endurance, see JEDEC Specification JESD218. TBW is defined as <math>1 \times 10^{12}</math> Bytes.</li> <li>Limited Warranty with Media Usage provides coverage for the warranty period or until the SSD Percentage Used field in the SMART Health Log reaches 100 whichever comes first.</li> </ul>

**NOTE**

Error rate specified with automatic retries and data correction with ECC enabled and all flaws reallocated.

## 8.2 Endurance

**Table 12 - Nytro 5060H - Lifetime write endurance by model**

Endurance Class	Capacity in GB	Standard	SED	FIPS 140-3	Lifetime PB JEDEC
Mixed Use	12,800	XP12800LEC0006	XP12800LEC0016	XP12800LEC0026	70
	6400	XP6400LEC0006	XP6400LEC0016	XP6400LEC0026	35
	3200	XP3200LEC0006	XP3200LEC0016	XP3200LEC0026	17.5
	1600	XP1600LEC0006	XP1600LEC0016	XP1600LEC0026	8.7
Read Intensive	15,360	XP15360SEC0006	XP15360SEC0016	XP15360SEC0026	28
	7680	XP7680SEC0006	XP7680SEC0016	XP7680SEC0026	14
	3840	XP3840SEC0006	XP3840SEC0016	XP3840SEC0026	7
	1920	XP1920SEC0006	XP1920SEC0016	XP1920SEC0026	3.5

**Table 13 - Nytro 5060S - Lifetime write endurance by model**

Endurance Class	Capacity in GB	Standard	SED	FIPS 140-3	Lifetime PB JEDEC
Mixed Use	12,800	XP12800LEC0076	XP12800LEC0046	XP12800LEC0056	70
	6400	XP6400LEC0076	XP6400LEC0046	XP6400LEC0056	35
	3200	XP3200LEC0076	XP3200LEC0046	XP3200LEC0056	17.5
	1600	XP1600LEC0076	XP1600LEC0046	XP1600LEC0056	8.7
Read Intensive	15,360	XP15360SEC0076	XP15360SEC0046	XP15360SEC0056	28
	7680	XP7680SEC0076	XP7680SEC0046	XP7680SEC0056	14
	3840	XP3840SEC0076	XP3840SEC0046	XP3840SEC0056	7
	1920	XP1920SEC0076	XP1920SEC0046	XP1920SEC0056	3.5

## 8.3 Error rates

The error rates stated in this manual assume the following:

- The drive is operated in accordance with this manual using DC power as defined in [Section 9.2 Power consumption](#).
- Errors caused by host system failures are excluded from error rate computations.
- Assume random data.
- Default OEM error recovery settings are applied. This includes full read retries, full write retries and full retry time.

### 8.3.1 Unrecoverable Errors

An unrecoverable data error is a failure of the drive to recover data from the media. These errors occur due to read or write problems. Unrecoverable data errors are only detected during read operations, but not caused by the read. If an unrecoverable data error is detected, the command will be completed with a Status Code Type (SCT) of 2h Media and Data Integrity Errors, with code 81h Unrecovered Read Error is reported. Multiple unrecoverable data errors resulting from the same cause are treated as one error.

### **8.3.2 Interface errors**

An interface error is defined as a failure of the receiver on a port to recover the data as transmitted by the device port connected to the receiver. The error may be detected as a running disparity error, illegal code, loss of word sync, or CRC error.

## **8.4 Endurance management**

Customer satisfaction with Solid State Drives can be directly related to the internal algorithms which an SSD uses to manage the limited number of Program-Erase (PE) cycles that NAND Flash can withstand. These algorithms consist of Wear Leveling, Garbage Collection, Write Amplification, Deallocation, Data Retention, and Lifetime Endurance Management.

### **8.4.1 Wear leveling**

The drive uses Wear Leveling to make sure that all Flash cells are written to or exercised as evenly as possible to avoid hot spots where some cells are used up faster than other locations. The drive automatically manages Wear Leveling without user interaction. The Seagate algorithm operates only when needed to ensure reliable product operation.

### **8.4.2 Garbage collection**

The drive uses Garbage Collection to consolidate valid user data into a common cell range freeing up unused or obsolete locations to be erased and used for future storage needs. The drive automatically manages Garbage Collection without user interaction. The Seagate algorithm operates only when needed to ensure reliable product operation.

### **8.4.3 Write amplification**

While Write Amplification is not an algorithm, it is a major characteristic of SSDs. Write Amplification must be accounted for by all the algorithms that the SSD implements. The Write Amplification Factor of an SSD is the ratio of Host/User data requested to be written to the actual amount of data written by the SSD internal to account for the user data and the housekeeping activities such as Wear Leveling and Garbage Collection. The Write Amplification Factor of an SSD can also be directly affected by the characteristics of the host data being sent to the SSD to write. The best Write Amplification Factor is achieved for data that is written in sequential LBAs that are aligned on 4KB boundaries. The worst case Write Amplification Factor occurs for randomly written LBA's of transfer sizes that are less than 4KB and that originate on LBA's that are not on 4KB boundaries.

### **8.4.4 Deallocation**

Deallocation is when the firmware uses the Dataset Management command, the Write Zeroes command, or the Sanitize command to deallocate logical blocks. This deallocation reduces the Write Amplification Factor of the drive during housekeeping tasks such as Wear Leveling and Garbage Collection. This happens because the drive does not need to retain data which has been classified by the host as obsolete.

## 8.4.5 Data retention

Data Retention is another major characteristic of SSDs that must be accounted for by all the algorithms that the SSD implements. While powered up, the Data Retention of SSD cells are monitored and rewritten if the cell levels decay to an unexpected level. Data Retention when the drive is powered off is affected by Program and Erase (PE) cycles and the temperature of the drive when stored.

## 8.4.6 SSD percentage used endurance indicator

An application can interrogate the drive through the host to determine an estimate of the percentage of device life that has been used. To accomplish this, issue a Get Log command to Log Identifier 2h. This allows applications to read the contents of the Percentage Used field in Byte 5. The Percentage Used field is defined in the NVM Express specifications available from the NVM Express consortium.

## 8.5 Reliability and service

Integrators can enhance the reliability of Seagate Nytro 5060 NVMe SSD drives by ensuring that the drive receives adequate cooling. [Section 9.3 Environmental limits](#) provides temperature measurements and other information that may be used to enhance the service life of the drive. [Section 12.1 Cooling](#) provides recommended air-flow information.

### 8.5.1 Annualized Failure Rate (AFR) and Mean Time Between Failure (MTBF)

The production drive shall achieve an AFR of 0.35% (MTBF of 2,500,000 hours) when operated in an environment that ensures the case temperatures do not exceed the values specified in [Section 9.3 Environmental limits](#). Operation at case temperatures outside the specifications in [Section 9.3 Environmental limits](#) may increase the product AFR (decrease the MTBF). The AFR (MTBF) is a population statistic not relevant to individual units.

The AFR (MTBF) specification is based on the following assumptions for Enterprise Storage System environments:

- 8760 power-on hours per year.
- 250 average on/off cycles per year.
- Operations at nominal voltages.

Systems will provide adequate cooling to ensure the case temperatures specified in [Section 12.1 Cooling](#) are not exceeded. Temperatures outside the specifications in [Section 12.1 Cooling](#) will increase the product AFR and decrease the MTBF.

### 8.5.2 Preventive maintenance

No routine scheduled preventive maintenance is required.

### 8.5.3 Hot plugging the drive

When a drive is powered on by switching the power or hot plugging, the drive runs a self test and attempts to detect and train the PCIe links. Link training happens on all lanes simultaneously. If there's a problem training a link or at a specific speed, the link may be downgraded to fewer links or lower link speed without reporting an error. The system maintainer needs to check the link status.

If self test detects a failure, the drive may still link and enumerate on the PCIe bus. If the Power Loss Protection (PLP) circuitry fails, the drive reports an error and becomes Read Only unless configured otherwise. Other errors can result in the drive not responding to the Controller Enable event (setting CC.EN = 1b).

**NOTE** The systems integrator is responsible for assuring that no temperature, energy, voltage hazard, or ESD potential hazard is presented during the hot connect/disconnect operation. Discharge the static electricity from the drive carrier prior to inserting it into the system.

#### 8.5.4 SMART

SMART is an acronym for Self-Monitoring Analysis and Reporting Technology. This technology is intended to recognize conditions that indicate imminent drive failure and is designed to provide sufficient warning of a failure to allow administrators to back up the data before an actual failure occurs.

**NOTE** The drive's firmware monitors specific attributes for degradation over time but can't predict instantaneous drive failures.

Each monitored attribute has been selected to monitor a specific set of failure conditions in the operating performance of the drive and the thresholds are optimized to minimize "false" and "failed" predictions.

#### 8.5.5 Thermal monitor

Seagate Nytro 5060 NVMe SSD drives implement a temperature warning system which:

1. Signals the host if the composite temperature exceeds the warning threshold, indicating an overheat condition during which the controller continues to operate.
2. Signals the host if the composite temperature exceeds the critical threshold, indicating an overheat condition which can prevent continued operation of the drive.
3. Saves a log entry on the drive which exceeds the temperature value.

A temperature sensor monitors the drive temperature and issues a warning composite over the interface when the temperature exceeds a set threshold.

The thermal monitor system generates an Asynchronous Event Report with code 0Dh to indicate the drive has logged a temperature excursion in the Persistent Event Log.

#### 8.5.6 Device Self Test

Device Self Test (DST) is a technology designed to recognize drive fault conditions that qualify the drive as a failed unit. DST validates the functionality of the drive at a system level. There are two test coverage options implemented in DST:

1. Extended test
2. Short test

The most thorough option is the extended test that performs various tests on the drive and scans every logical block address (LBA) of the drive. The short test is time-restricted and limited in length—it does not scan the entire media contents, but does some fundamental tests and scans portions of the media. If DST encounters an error during either of these tests, it reports a "diagnostic failed" condition. If the drive fails the test, remove it and return it to Seagate for service.

### 8.5.6.1 DST failure definition

The drive will present a "diagnostic failed" condition through the self-tests results value of the diagnostic log page if a functional failure is encountered during DST. The drive parameters are not modified to test the drive more stringently, and the recovery capabilities are not reduced. All retries and recovery processes are enabled during the test. If data is recoverable, no failure condition will be reported regardless of the processes required to recover the data. The following conditions are considered DST failure conditions:

- Read error after recovery attempts are exhausted
- Write error after recovery attempts are exhausted

### 8.5.6.2 Implementation

This section provides all of the information necessary to implement the DST function on this drive.

### 8.5.6.3 State of the drive prior to testing

The drive must be in a ready state before issuing the Device Self-test command. There are multiple reasons why a drive may not be ready, some of which are valid conditions, and not errors. For example, a drive may be in the process of doing a Format NVM, or another DST. It is the responsibility of the host application to determine the "not ready" cause.

### 8.5.6.4 Engage DST

To run DST, submit the Device Self-test command with the appropriate Self-test Code (STC) (1h for the short test or 2h for the extended test) in Command Dword 10, bits 03:00.

DST has two options:

Short test (Self Test Code: 1h)

The short test provides a time-limited test that tests as much of the drive as possible within 120 seconds. The short test does not scan the entire media contents, but does some fundamental tests and scans portions of the media. A complete read/verify scan is not performed and only factual failures will report a "test failed" condition. This option provides a quick confidence test of the drive.

Extended test (Self Test Code: 2h)

The extended test empirically tests critical drive components. The read operation tests the media contents. The integrity of the media is checked through a read/verify scan of the media. The anticipated length of the Extended test is reported through the Extended Device Self-Test Time field in the Identify Controller data structure.

### 8.5.6.5 Log page entries

When the drive begins DST, it creates a new entry in the Self-test Result Data Structure in Log Identifier 06h. The new entry is created by inserting a new self test data structure starting at byte 4h of the Device Self-test Log. Existing data is moved to make room for the new data structure. The drive reports 20 result data structures in the log. If there are more than 20 result data structures, the oldest data structure is deleted. The new data structure is initialized.

### 8.5.6.6 Abort

Abort test options include:

- Applications can use the abort code Fh in the Self-test Code field of the Device Self-test command. This causes a result of 1h (self-test aborted by a Device Self-test command) to appear in the result bits (3:0) of the Device Self-test Status field.
- Any Controller-level reset that affects the controller performing the device self-test. This causes 2h (self-test aborted by a Controller Level Reset) to appear in the result bits of the Device Self-test Status field.

## 8.5.7 Product warranty

For information regarding warranty support details, visit:  
<http://www.seagate.com/support/warranty-and-replacements/>

**Limited Warranty with Media Usage:** This warranty is based on the shorter of term and endurance usage of the drive.

## 8.5.8 Shipping

When transporting or shipping a drive, use only a Seagate-approved container. Keep the original box. Seagate approved containers are easily identified by the Seagate Approved Package label. Shipping a drive in a non-approved container voids the drive warranty.

Seagate repair centers may refuse receipt of components improperly packaged or obviously damaged in transit. Contact the authorized Seagate distributor to purchase additional boxes. Seagate recommends shipping by an air-ride carrier experienced in handling computer equipment.

### 8.5.8.1 Product repair and return information

Seagate customer service centers are the only facilities authorized to service Seagate drives. Seagate does not sanction any third-party repair facilities. Any unauthorized repair or tampering with the factory seal voids the warranty.

### 8.5.8.2 Storage

You can store the drive for a maximum of 180 days in the original unopened Seagate shipping package or 60 days, unpackaged, in the defined non-operating limits (refer to environmental section in this manual). You can extend storage to 1 year packaged or unpackaged under optimal environmental conditions (<40°C, <40% relative humidity non-condensing, and non-corrosive environment). During any storage period you must follow the drive non-operational temperature, humidity, wet bulb, atmospheric conditions, shock, vibration, magnetic and electrical field specifications.



## 9. Physical and electrical specifications

This section provides information relating to the physical and electrical characteristics of the drive.

### 9.1 Power specifications

The E3.S SSD receives DC power (+12V and optionally +3.3Vaux) through the PCIe interface. Both +12V and +3.3Vaux supplies should employ separate ground returns.

Where power is provided to multiple drives from a common supply, careful consideration for individual drive power requirements should be noted. Where multiple units are powered on simultaneously, the peak starting current must be available to each device.

Parameters, other than start, are measured after a 10-minute warm up.

**Table 14 - +12V Requirements**

Supply Tolerance	+10% / -10%
Absolute Maximum Voltage	14V
Supply Rise Time	0.1 to 50 ms
Supply Drop Time	0.1 to 500 ms
Typical Capacitance	0.1 $\mu$ f

**Table 15 - +3.3V Requirements**

Supply Tolerance	+5% / -10%
Absolute Maximum Voltage	3.63V
Supply Rise Time	0.1 to 50 ms
Supply Drop Time	0.1 to 500 ms
Typical Capacitance	0.5 nf

#### 9.1.1 Conducted noise immunity

Noise is specified as a periodic and random distribution of frequencies covering a defined frequency. Maximum allowed noise values given below are peak-to-peak measurements and apply at the drive power connector.

- 350 mV pp from 100 Hz to 20 MHz
- 150 mV pp from 10 MHz to 80 MHz

## 9.2 Power consumption

Table 16 - Nytro 5060H E3.S Power Consumption by Capacity

Nytro 5560H E3.S, 1600GB Power Consumption		
Parameter		
Voltage	+12V	
Regulation	+/-10%	
	Current (A)	Power (W)
Average Idle Current	0.38	4.5
Maximum Start Current		
Average DC	0.92	11.1
Maximum DC (Peak)	1.17	
Operating Current (Random Read)		
Average DC	1.35	16.2
Maximum DC	1.36	16.2
Maximum DC (peak)	1.62	
Operating Current (Random Write)		
Average DC	1.32	15.8
Maximum DC	1.35	16.2
Maximum DC (peak)	1.74	
Operating Current (Sequential Read)		
Average DC	1.49	17.9
Maximum DC	1.55	18.6
Maximum DC (peak)	1.74	
Operating Current (Sequential Write)		
Average DC	1.27	15.3
Maximum DC	1.35	16.2
Maximum DC (peak)	1.74	
Nytro 5560H E3.S, 3200GB Power Consumption		
Parameter		
Voltage	+12V	
Regulation	+/-5%	
	Current (A)	Power (W)
Average Idle Current	0.38	4.5
Maximum Start Current		
Average DC	1.18	14.3
Maximum DC (Peak)	1.40	
Operating Current (Random Read)		
Average DC	1.65	19.7
Maximum DC	1.66	19.8

**Table 16 - Nytro 5060H E3.S Power Consumption by Capacity (continued)**

<b>Maximum DC (peak)</b>	1.87	
<b>Operating Current (Random Write)</b>		
<b>Average DC</b>	1.84	22.0
<b>Maximum DC</b>	1.91	22.9
<b>Maximum DC (peak)</b>	2.35	
<b>Operating Current (Sequential Read)</b>		
<b>Average DC</b>	1.56	18.7
<b>Maximum DC</b>	1.63	19.5
<b>Maximum DC (peak)</b>	1.84	
<b>Operating Current (Sequential Write)</b>		
<b>Average DC</b>	1.72	20.6
<b>Maximum DC</b>	1.88	22.5
<b>Maximum DC (peak)</b>	2.32	
<b>Nytro 5560H E3.S, 6400GB Power Consumption</b>		
<b>Parameter</b>		
<b>Voltage</b>	+12V	
<b>Regulation</b>	+/-5%	
	<b>Current (A)</b>	<b>Power (W)</b>
<b>Average Idle Current</b>	0.39	4.7
<b>Maximum Start Current</b>		
<b>Average DC</b>	1.35	16.3
<b>Maximum DC (Peak)</b>	1.61	
<b>Operating Current (Random Read)</b>		
<b>Average DC</b>	1.73	20.7
<b>Maximum DC</b>	1.74	20.8
<b>Maximum DC (peak)</b>	1.99	
<b>Operating Current (Random Write)</b>		
<b>Average DC</b>	1.79	21.4
<b>Maximum DC</b>	2.21	26.3
<b>Maximum DC (peak)</b>	2.71	
<b>Operating Current (Sequential Read)</b>		
<b>Average DC</b>	1.56	18.7
<b>Maximum DC</b>	1.64	19.7

**Table 16 - Nytro 5060H E3.S Power Consumption by Capacity (continued)**

<b>Maximum DC (peak)</b>	1.90	
<b>Operating Current (Sequential Write)</b>		
<b>Average DC</b>	1.82	21.8
<b>Maximum DC</b>	2.01	24.0
<b>Maximum DC (peak)</b>	2.82	
<b>Nytro 5560H E3.S, 12,800GB Power Consumption</b>		
<b>Parameter</b>		
<b>Voltage</b>	+12V	
<b>Regulation</b>	+/-5%	
	<b>Current (A)</b>	<b>Power (W)</b>
<b>Average Idle Current</b>	0.39	4.7
<b>Maximum Start Current</b>		
<b>Average DC</b>	1.38	16.5
<b>Maximum DC (Peak)</b>	1.63	
<b>Operating Current (Random Read)</b>		
<b>Average DC</b>	2.01	24.0
<b>Maximum DC</b>	2.01	24.1
<b>Maximum DC (peak)</b>	2.22	
<b>Operating Current (Random Write)</b>		
<b>Average DC</b>	1.94	23.2
<b>Maximum DC</b>	2.06	24.7
<b>Maximum DC (peak)</b>	3.41	
<b>Operating Current (Sequential Read)</b>		
<b>Average DC</b>	1.8	21.5
<b>Maximum DC</b>	1.82	21.8
<b>Maximum DC (peak)</b>	2.10	
<b>Operating Current (Sequential Write)</b>		
<b>Average DC</b>	2.00	23.9
<b>Maximum DC</b>	2.03	24.3
<b>Maximum DC (peak)</b>	2.86	
<b>Nytro 5360H E3.S, 1920GB Power Consumption</b>		
<b>Parameter</b>		
<b>Voltage</b>	+12V	
<b>Regulation</b>	+/-5%	
	<b>Current (A)</b>	<b>Power (W)</b>
<b>Average Idle Current</b>	0.38	4.6

**Table 16 - Nytro 5060H E3.S Power Consumption by Capacity (continued)**

<b>Maximum Start Current</b>		
<b>Average DC</b>	0.93	11.2
<b>Maximum DC (Peak)</b>	0.99	
<b>Operating Current (Random Read)</b>		
<b>Average DC</b>	1.36	16.3
<b>Maximum DC</b>	1.37	16.4
<b>Maximum DC (peak)</b>	1.65	
<b>Operating Current (Random Write)</b>		
<b>Average DC</b>	1.37	16.4
<b>Maximum DC</b>	1.40	16.7
<b>Maximum DC (peak)</b>	1.79	
<b>Operating Current (Sequential Read)</b>		
<b>Average DC</b>	1.49	17.9
<b>Maximum DC</b>	1.56	18.7
<b>Maximum DC (peak)</b>	1.81	
<b>Operating Current (Sequential Write)</b>		
<b>Average DC</b>	1.29	15.5
<b>Maximum DC</b>	1.36	16.3
<b>Maximum DC (peak)</b>	1.74	
<b>Nytro 5360H E3.S, 3840GB Power Consumption</b>		
<b>Parameter</b>		
<b>Voltage</b>	+12V	
<b>Regulation</b>	+/-5%	
	<b>Current (A)</b>	<b>Power (W)</b>
<b>Average Idle Current</b>	0.39	4.7
<b>Maximum Start Current</b>		
<b>Average DC</b>	1.18	14.2
<b>Maximum DC (Peak)</b>	1.42	
<b>Operating Current (Random Read)</b>		
<b>Average DC</b>	1.65	19.8
<b>Maximum DC</b>	1.66	19.8
<b>Maximum DC (peak)</b>	1.92	
<b>Operating Current (Random Write)</b>		
<b>Average DC</b>	1.91	22.8
<b>Maximum DC</b>	1.96	23.4
<b>Maximum DC (peak)</b>	2.35	
<b>Operating Current (Sequential Read)</b>		
<b>Average DC</b>	1.51	18.1
<b>Maximum DC</b>	1.59	19.1
<b>Maximum DC (peak)</b>	1.79	

Table 16 - Nytro 5060H E3.S Power Consumption by Capacity (*continued*)

<b>Operating Current (Sequential Write)</b>		
Average DC	1.72	20.6
Maximum DC	1.91	22.9
Maximum DC (peak)	2.34	
<b>Nytr 5360H E3.S, 7680GB Power Consumption</b>		
<b>Parameter</b>		
Voltage	+12V	
Regulation	+/-5%	
	<b>Current (A)</b>	<b>Power (W)</b>
Average Idle Current	0.38	4.5
<b>Maximum Start Current</b>		
Average DC	1.13	13.6
Maximum DC (Peak)	1.31	
<b>Operating Current (Random Read)</b>		
Average DC	1.73	20.7
Maximum DC	1.73	20.8
Maximum DC (peak)	1.97	
<b>Operating Current (Random Write)</b>		
Average DC	2.03	24.2
Maximum DC	2.25	26.9
Maximum DC (peak)	2.69	
<b>Operating Current (Sequential Read)</b>		
Average DC	1.52	18.3
Maximum DC	1.63	19.5
Maximum DC (peak)	1.87	
<b>Operating Current (Sequential Write)</b>		
Average DC	1.75	21.0
Maximum DC	2.02	24.2
Maximum DC (peak)	2.83	
<b>Nytr 5360H E3.S, 15,360GB Power Consumption</b>		
<b>Parameter</b>		
Voltage	+12V	
Regulation	+/-5%	
	<b>Current (A)</b>	<b>Power (W)</b>
Average Idle Current	0.39	4.8
<b>Maximum Start Current</b>		
Average DC	1.38	16.6
Maximum DC (Peak)	1.63	
<b>Operating Current (Random Read)</b>		

**Table 16 - Nytro 5060H E3.S Power Consumption by Capacity (continued)**

<b>Average DC</b>	2.00	23.9
<b>Maximum DC</b>	2.01	24.0
<b>Maximum DC (peak)</b>	2.27	
<b>Operating Current (Random Write)</b>		
<b>Average DC</b>	2.17	25.9
<b>Maximum DC</b>	2.37	28.2
<b>Maximum DC (peak)</b>	3.39	
<b>Operating Current (Sequential Read)</b>		
<b>Average DC</b>	1.80	21.5
<b>Maximum DC</b>	1.82	21.8
<b>Maximum DC (peak)</b>	2.12	
<b>Operating Current (Sequential Write)</b>		
<b>Average DC</b>	1.80	21.5
<b>Maximum DC</b>	1.82	21.8
<b>Maximum DC (peak)</b>	2.12	

**Table 17 - Nytro 5060S E3.S Power Consumption by Capacity**

<b>Nytro 5560S E3.S, 1600GB Power Consumption</b>		
<b>Parameter</b>		
<b>Voltage</b>	+12V	
<b>Regulation</b>	+/-5%	
	<b>Current (A)</b>	<b>Power (W)</b>
<b>Average Idle Current</b>	0.38	4.6
<b>Maximum Start Current</b>		
<b>Average DC</b>	0.97	11.7
<b>Maximum DC (Peak)</b>	1.58	
<b>Operating Current (Random Read)</b>		
<b>Average DC</b>	1.27	15.3
<b>Maximum DC</b>	1.28	15.3
<b>Maximum DC (peak)</b>	1.53	
<b>Operating Current (Random Write)</b>		
<b>Average DC</b>	1.32	15.8
<b>Maximum DC</b>	1.35	16.3
<b>Maximum DC (peak)</b>	1.74	
<b>Operating Current (Sequential Read)</b>		
<b>Average DC</b>	1.39	16.7
<b>Maximum DC</b>	1.41	16.9
<b>Maximum DC (peak)</b>	1.73	
<b>Operating Current (Sequential Write)</b>		

**Table 17 - Nytro 5060S E3.S Power Consumption by Capacity (continued)**

<b>Average DC</b>	1.25	15.1
<b>Maximum DC</b>	1.27	15.2
<b>Maximum DC (peak)</b>	1.75	
<b>Nytro 5560S E3.S, 3200GB Power Consumption</b>		
<b>Parameter</b>		
<b>Voltage</b>	+12V	
<b>Regulation</b>	+/-5%	
	<b>Current (A)</b>	<b>Power (W)</b>
<b>Average Idle Current</b>	0.38	4.6
<b>Maximum Start Current</b>		
<b>Average DC</b>	1.30	15.6
<b>Maximum DC (Peak)</b>	1.45	
<b>Operating Current (Random Read)</b>		
<b>Average DC</b>	1.55	18.5
<b>Maximum DC</b>	1.55	18.6
<b>Maximum DC (peak)</b>	1.77	
<b>Operating Current (Random Write)</b>		
<b>Average DC</b>	1.87	22.4
<b>Maximum DC</b>	1.92	23.0
<b>Maximum DC (peak)</b>	2.33	
<b>Operating Current (Sequential Read)</b>		
<b>Average DC</b>	1.43	17.2
<b>Maximum DC</b>	1.44	17.3
<b>Maximum DC (peak)</b>	1.71	
<b>Operating Current (Sequential Write)</b>		
<b>Average DC</b>	1.80	21.6
<b>Maximum DC</b>	1.83	21.9
<b>Maximum DC (peak)</b>	2.26	
<b>Nytro 5560S E3.S, 6400GB Power Consumption</b>		
<b>Parameter</b>		
<b>Voltage</b>	+12V	
<b>Regulation</b>	+/-5%	
	<b>Current (A)</b>	<b>Power (W)</b>
<b>Average Idle Current</b>	0.37	4.5
<b>Maximum Start Current</b>		
<b>Average DC</b>	1.24	14.6



Table 17 - Nytro 5060S E3.S Power Consumption by Capacity (continued)

<b>Maximum DC (Peak)</b>	1.33	
<b>Operating Current (Random Read)</b>		
<b>Average DC</b>	1.66	19.7
<b>Maximum DC</b>	1.67	19.8
<b>Maximum DC (peak)</b>	1.84	
<b>Operating Current (Random Write)</b>		
<b>Average DC</b>	1.98	23.4
<b>Maximum DC</b>	2.25	25.5
<b>Maximum DC (peak)</b>	2.89	
<b>Operating Current (Sequential Read)</b>		
<b>Average DC</b>	1.47	17.5
<b>Maximum DC</b>	1.48	17.6
<b>Maximum DC (peak)</b>	1.72	
<b>Operating Current (Sequential Write)</b>		
<b>Average DC</b>	1.83	21.6
<b>Maximum DC</b>	1.87	22.2
<b>Maximum DC (peak)</b>	2.28	
<b>Nytro 5560S E3.S, 12,800GB Power Consumption</b>		
<b>Parameter</b>		
<b>Voltage</b>	+12V	
<b>Regulation</b>	+/-5%	
	<b>Current (A)</b>	<b>Power (W)</b>
<b>Average Idle Current</b>	0.39	4.6
<b>Maximum Start Current</b>		
<b>Average DC</b>	1.41	16.6
<b>Maximum DC (Peak)</b>	1.77	
<b>Operating Current (Random Read)</b>		
<b>Average DC</b>	1.92	22.5
<b>Maximum DC</b>	1.93	22.6
<b>Maximum DC (peak)</b>	2.15	
<b>Operating Current (Random Write)</b>		
<b>Average DC</b>	2.14	24.1
<b>Maximum DC</b>	2.41	28.0
<b>Maximum DC (peak)</b>	3.38	

Table 17 - Nytro 5060S E3.S Power Consumption by Capacity (continued)

<b>Operating Current (Sequential Read)</b>		
Average DC	1.78	21.0
Maximum DC	1.791	21.1
Maximum DC (peak)	2.02	
<b>Operating Current (Sequential Write)</b>		
Average DC	2.02	23.6
Maximum DC	2.04	24.0
Maximum DC (peak)	2.91	
<b>Nytro 5360S E3.S, 1920GB Power Consumption</b>		
<b>Parameter</b>		
Voltage	+12V	
Regulation	+/-5%	
	<b>Current (A)</b>	<b>Power (W)</b>
Average Idle Current	0.39	4.7
<b>Maximum Start Current</b>		
Average DC	0.94	11.3
Maximum DC (Peak)	1.04	
<b>Operating Current (Random Read)</b>		
Average DC	1.28	15.4
Maximum DC	1.29	15.5
Maximum DC (peak)	1.57	
<b>Operating Current (Random Write)</b>		
Average DC	1.37	16.5
Maximum DC	1.39	16.7
Maximum DC (peak)	1.77	
<b>Operating Current (Sequential Read)</b>		
Average DC	1.41	16.9
Maximum DC	1.41	17.0
Maximum DC (peak)	1.67	
<b>Operating Current (Sequential Write)</b>		
Average DC	1.26	15.2
Maximum DC	1.27	15.3
Maximum DC (peak)	1.75	
<b>Nytro 5360S E3.S, 3840GB Power Consumption</b>		
<b>Parameter</b>		
Voltage	+12V	
Regulation	+/-5%	
	<b>Current (A)</b>	<b>Power (W)</b>

Table 17 - Nytro 5060S E3.S Power Consumption by Capacity (continued)

Average Idle Current	0.39	4.7
Maximum Start Current		
Average DC	1.14	13.7
Maximum DC (Peak)	1.26	
Operating Current (Random Read)		
Average DC	1.56	18.3
Maximum DC	1.57	18.4
Maximum DC (peak)	1.83	
Operating Current (Random Write)		
Average DC	1.96	22.9
Maximum DC	2.01	23.5
Maximum DC (peak)	2.33	
Operating Current (Sequential Read)		
Average DC	1.50	17.6
Maximum DC	1.51	17.7
Maximum DC (peak)	1.68	
Operating Current (Sequential Write)		
Average DC	1.84	21.5
Maximum DC	1.88	21.9
Maximum DC (peak)	2.28	
<b>Nytro 5360S E3.S, 7680GB Power Consumption</b>		
Parameter		
Voltage	+12V	
Regulation	+/-5%	
	<b>Current (A)</b>	<b>Power (W)</b>
Average Idle Current	0.38	4.6
Maximum Start Current		
Average DC	1.22	14.6
Maximum DC (Peak)	1.50	
Operating Current (Random Read)		
Average DC	1.69	20.2
Maximum DC	1.70	20.3
Maximum DC (peak)	1.96	
Operating Current (Random Write)		
Average DC	2.07	24.7
Maximum DC	2.304	27.6
Maximum DC (peak)	2.87	
Operating Current (Sequential Read)		
Average DC	1.44	17.2
Maximum DC	1.44	17.3

**Table 17 - Nytro 5060S E3.S Power Consumption by Capacity (continued)**

<b>Maximum DC (peak)</b>	1.71	
<b>Operating Current (Sequential Write)</b>		
<b>Average DC</b>	1.82	21.8
<b>Maximum DC</b>	1.86	22.3
<b>Maximum DC (peak)</b>	2.30	
<b>Nytro 5360S E3.S, 15,360GB Power Consumption</b>		
<b>Parameter</b>		
<b>Voltage</b>	+12V	
<b>Regulation</b>	+/-5%	
	<b>Current (A)</b>	<b>Power (W)</b>
<b>Average Idle Current</b>	0.40	4.8
<b>Maximum Start Current</b>		
<b>Average DC</b>	1.46	17.3
<b>Maximum DC (Peak)</b>	1.65	
<b>Operating Current (Random Read)</b>		
<b>Average DC</b>	1.92	22.5
<b>Maximum DC</b>	1.93	22.6
<b>Maximum DC (peak)</b>	2.15	
<b>Operating Current (Random Write)</b>		
<b>Average DC</b>	2.22	25.9
<b>Maximum DC</b>	2.37	27.6
<b>Maximum DC (peak)</b>	3.37	
<b>Operating Current (Sequential Read)</b>		
<b>Average DC</b>	1.78	20.9
<b>Maximum DC</b>	1.79	20.1
<b>Maximum DC (peak)</b>	1.97	
<b>Operating Current (Sequential Write)</b>		
<b>Average DC</b>	2.03	23.7
<b>Maximum DC</b>	2.06	24.0
<b>Maximum DC (peak)</b>	2.85	

**NOTES**

Typical power measurements are based on an average of drives tested, under nominal conditions, using the input voltage 12V (+/-10%) at 60°C internal temperature. Measured with LPM enabled.

## 9.3 Environmental limits

Temperature and humidity values experienced by the drive must be such that condensation does not occur on any drive part. Altitude and atmospheric pressures are specified to a standard day at 58.7°F (14.8°C). Maximum wet bulb temperature is 84.2°F (29°C).

**NOTE** To maintain optimal performance drives should be run at nominal case temperatures.

### 9.3.1 Temperature

#### 9.3.1.1 Operating

The drive meets the operating specifications over a 32°F to 167°F (0°C to 70°C) drive internal temperature range with a maximum temperature gradient of 86°F (30°C) per hour.

**NOTE** Internal temperature swings greater than 55°C during over a 3 day time period may cause an elevated read error rate.

The maximum allowable drive internal temperature is 70°C. If the enclosure environment is unable to keep the internal temperature below this value the drive will reduce write activity to avoid an over-temperature condition. When the internal temperature is equal or greater than 65°C the drive will issue a SMART thermal warning.

The MTBF specification for the drive assumes the operating environment is designed to maintain nominal internal temperature. The rated MTBF is based upon a sustained internal temperature of 122°F (50°C). Occasional excursions in operating temperature between the rated MTBF temperature and the maximum drive operating internal temperature may occur without impact to the rated MTBF temperature. However continual or sustained operation at internal temperatures beyond the rated MTBF temperature will degrade the drive MTBF and reduce product reliability.

Air flow across the drive is expected under moderate to heavy write data workloads to stay under internal temperature limits described in this section. To confirm that the required cooling is provided, place the drive in its final mechanical configuration, and perform highest data throughput for the given application. Writing large transfers sequentially will consume the most current. After the temperatures stabilize, read the internal temperature of the drive using Seagate SeaChest or SeaTools utilities available at <https://www.seagate.com/support/downloads>.

#### 9.3.1.2 Non-operating

-40° to 185°F (-40° to 85°C) package ambient with a maximum gradient of 86°F (30°C) per hour. This specification assumes that the drive is packaged in the shipping container designed by Seagate for use with the drive.

### 9.3.2 Relative humidity

The values below assume that no condensation on the drive occurs.

- Operating  
5% to 95% non-condensing relative humidity with a maximum gradient of 20% per hour.
- Non-operating  
5% to 95% non-condensing relative humidity.

### 9.3.3 Effective altitude (sea level)

- Operating  
-1000 to +10,000 feet (0 to +3048 meters)
- Non-operating  
-1000 to +40,000 feet (0 to +12,192 meters)

### 9.3.4 Shock and vibration

Shock and vibration limits specified in this document are measured directly on the drive chassis. If the drive is installed in an enclosure to which the stated shock and/or vibration criteria is applied, resonances may occur internally to the enclosure resulting in drive movement in excess of the stated limits. If this situation is apparent, it may be necessary to modify the enclosure to minimize drive movement.

#### 9.3.4.1 Shock

- Operating - normal

The drive, as installed for normal operation, shall operate error free while subjected to intermittent shock not exceeding:

1000 Gs at a maximum duration of 0.5ms (half sinewave)

Shock may be applied in the X, Y, or Z axis. Shock is not to be repeated more than once every 2 seconds.

**NOTE** This specification does not cover connection issues that may result from testing at this level.

- Non-operating

The limits of non-operating shock shall apply to all conditions of handling and transportation. This includes both isolated drives and integrated drives.

The drive subjected to non-repetitive shock not exceeding:

1000 Gs at a maximum duration of 0.5ms (half sinewave), shall not exhibit device damage or performance degradation.

Shock may be applied in the X, Y, or Z axis.

- Packaged

Seagate finished drive bulk packs are designed and tested to meet or exceed applicable ISTA and ASTM standards. Volume finished drives will be shipped from Seagate factories on pallets to minimize freight costs and ease material handling. Seagate finished drive bulk packs may be shipped individually. For less than full shipments, instructions are printed on the bulk pack carton for minimum drive quantities and proper drive placement.

#### 9.3.4.2 Vibration

- Operating - normal

The drives installed for normal operation shall comply with the complete specified performance while subjected to vibration applied in the X, Y, or Z axis.

Operating normal translational random shaped profile: 7-800 Hz, 2.17 Grms

- Operating - abnormal

Equipment as installed for normal operation shall not incur physical damage while subjected to periodic vibration:

Vibration occurring at these levels may degrade operational performance during the abnormal vibration period. Specified operational performance will continue when normal operating vibration levels are resumed. This assumes system recovery routines are available.

Operating abnormal translational random shaped profile: 10-2000 Hz, 16.3 Grms

- Non-operating

The limits of non-operating vibration shall apply to all conditions of handling and transportation. This includes both isolated drives and integrated drives.

The drive shall not incur physical damage or degraded performance as a result of vibration.

Vibration may be applied in the X, Y, or Z axis.

Non-operating translational random shaped profile: 10-2000 Hz, 16.3 Grms

**NOTE** This specification does not cover connection issues that may result from testing at this level.

#### 9.3.5 Air cleanliness

The drive is designed to operate in a typical office environment with minimal environmental control.

#### 9.3.6 Corrosive environment

Seagate electronic drive components pass accelerated corrosion testing equivalent to 10 years exposure to light industrial environments containing sulfurous gases, chlorine and nitric oxide, classes G and H per ASTM B845. However, this accelerated testing cannot duplicate every potential application environment.

Users should use caution exposing any electronic components to uncontrolled chemical pollutants and corrosive chemicals as electronic drive component reliability can be affected by the installation environment. The silver, copper, nickel and gold films used in Seagate products are especially sensitive to the presence of sulfide, chloride, and nitrate contaminants. Sulfur is found to be the most damaging. Materials used in cabinet fabrication, such as vulcanized rubber, that can outgas corrosive compounds should be minimized or eliminated. The useful life of any electronic equipment may be extended by replacing materials near circuitry with sulfide-free alternatives.

Seagate recommends that data centers be kept clean by monitoring and controlling the dust and gaseous contamination. Gaseous contamination should be within ANSI/ISA 571.04-2013 G1 classification levels (as measured on copper and silver coupons), and dust contamination to ISO 14644-1 Class 8 standards, and MTBF rated conditions as defined in the Annualized Failure Rate (AFR) and Mean Time Between Failure (MTBF) section.

## 9.4 Mechanical specifications

See the below figures for detailed mounting configuration dimensions.

Figure 1 Mounting configuration E3.S 1T

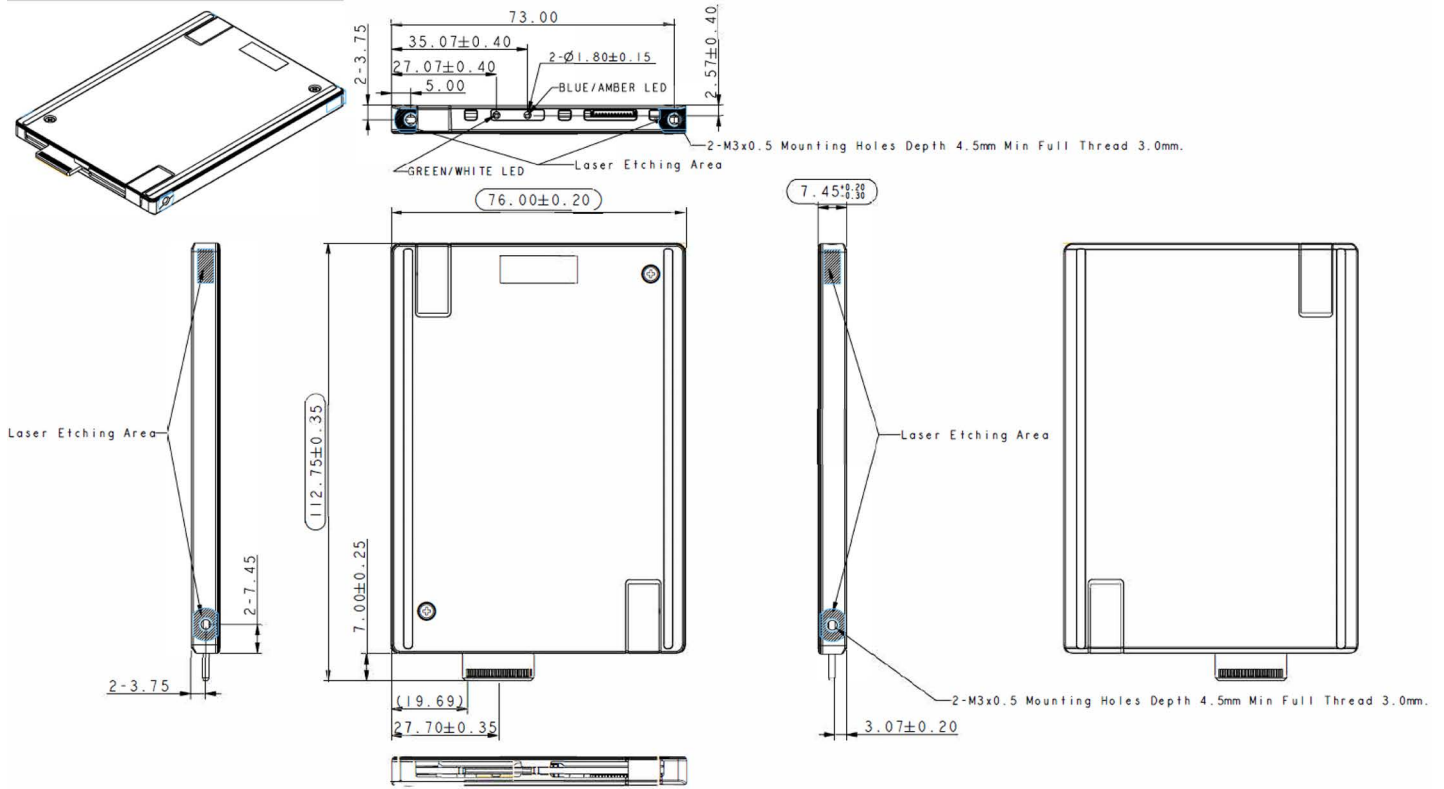



## 9.4.1 Nytro 5060 Weights

**Table 18 - Nytro 5060H E3.S Weight by Model**

Endurance Class	Capacity in GB	ISE	SED	FIPS 140-3	Grams
Mixed Use	12,800	XP12800LEC0006	XP12800LEC0016	XP12800LEC0026	120
	6400	XP6400LEC0006	XP6400LEC0016	XP6400LEC0026	120
	3200	XP3200LEC0006	XP3200LEC0016	XP3200LEC0026	115
	1600	XP1600LEC0006	XP1600LEC0016	XP1600LEC0026	110
Read Intensive	15,360	XP15360SEC0006	XP15360SEC0016	XP15360SEC0026	120
	7680	XP7680SEC0006	XP7680SEC0016	XP7680SEC0026	120
	3840	XP3840SEC0006	XP3840SEC0016	XP3840SEC0026	115
	1920	XP1920SEC0006	XP1920SEC0016	XP1920SEC0026	110

**Table 19 - Nytro 5060S E3.S Weight by Model**

Endurance Class	Capacity in GB	ISE	SED	FIPS 140-3	Grams
Mixed Use	12,800	XP12800LEC0076	XP12800LEC0046	XP12800LEC0056	120
	6400	XP6400LEC0076	XP6400LEC0046	XP6400LEC0056	120
	3200	XP3200LEC0076	XP3200LEC0046	XP3200LEC0056	115
	1600	XP1600LEC0076	XP1600LEC0046	XP1600LEC0056	110
Read Intensive	15,360	XP15360SEC0076	XP15360SEC0046	XP15360SEC0056	120
	7680	XP7680SEC0076	XP7680SEC0046	XP7680SEC0056	120
	3840	XP3840SEC0076	XP3840SEC0046	XP3840SEC0056	115
	1920	XP1920SEC0076	XP1920SEC0046	XP1920SEC0056	110

## 9.5 Connector specification

### 9.5.1 Connector specification

Figure 2, *Physical Interface* shows the location of the E3.S PCIe SSD connector. Figure 3, *E3.S device plug mechanical drawing* shows the card edge mechanical drawing for convenience only. For detailed views as well as the interface's physical, electrical, and logical characteristics, refer to specification SFF-TA-1002 available at [www.snia.org](http://www.snia.org).

Figure 2 Physical Interface

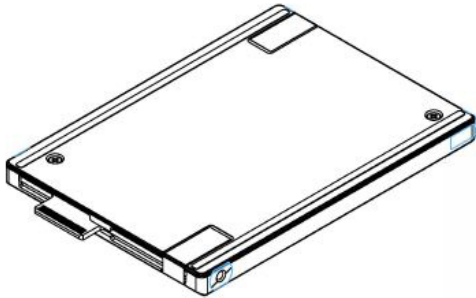
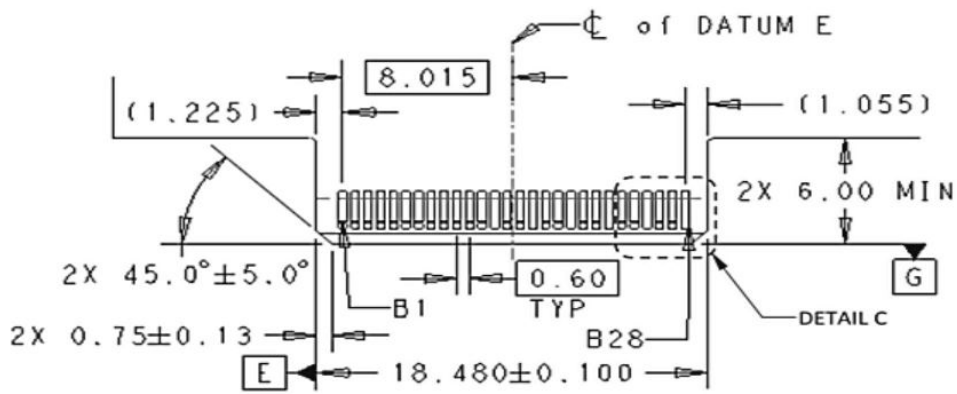

Figure 3 E3.S device plug mechanical drawing



Note: Position A1 on opposite side of card of B1

## 9.5.2 Pin descriptions

This section provides a pin-out of the E3.S device and a description of the functions provided by the pins.

**Figure 4 E3.S SSD Pin Assignment**

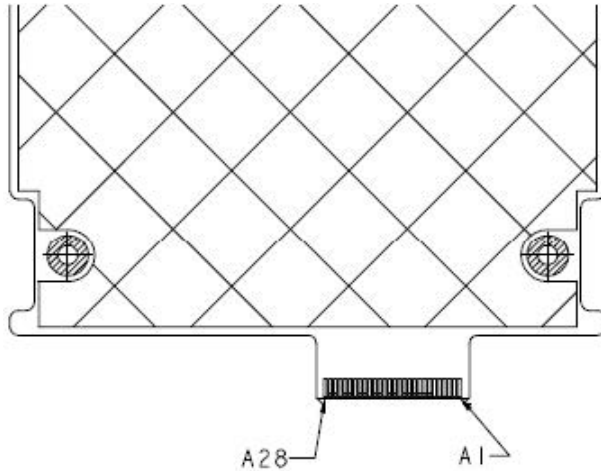

**Table 20 Connector E3.S Pin Assignment and Descriptions**

Pin No.	Name	Type	Description
A1	Ground	Ground	Ground
A2	Ground	Ground	Ground
A3	Ground	Ground	Ground
A4	Ground	Ground	Ground
A5	Ground	Ground	Ground
A6	Ground	Ground	Ground
A7	SMCLK	Bi-Dir	SMBus (System Management Bus) clock
A8	SMDAT	Bi-Dir	SMBus (System Management Bus) data
A9	SMRST#	Output	SMBus (System Management Bus) reset
A10	LED	Output	Drive LED state
A11	CLKREQ#/PERSTB#	Bi-Dir	Clock request/Fundamental reset for second X2 port
A12	PRSNT#	Input	Presence detect
A13	Ground	Ground	Ground
A14	REFCLKB-	Diff-Pair	Reference clock (differential pair) for second X2 port
A15	REFCLKB+	Diff-Pair	Reference clock (differential pair) for second X2 port
A16	Ground	Ground	Ground
A17	E3.S RX n0	Diff-Pair	Receiver differential pair, E3.S Lane 0
A18	E3.S RX p0	Diff-Pair	Receiver differential pair, E3.S Lane 0
A19	Ground	Ground	Ground
A20	E3.S RX n1	Diff-Pair	Receiver differential pair, E3.S Lane 1
A21	E3.S RX p1	Diff-Pair	Receiver differential pair, E3.S Lane 1
A22	Ground	Ground	Ground
A23	E3.S RX n2	Diff-Pair	Receiver differential pair, E3.S Lane 2

**Table 20 Connector E3.S Pin Assignment and Descriptions**

A24	E3.S RX p2	Diff-Pair	Receiver differential pair, E3.S Lane 2
A25	Ground	Ground	Ground
A26	E3.S RX n3	Diff-Pair	Receiver differential pair, E3.S Lane 3
A27	E3.S RX p3	Diff-Pair	Receiver differential pair, E3.S Lane 3
A28	Ground	Ground	Ground
B1	+12V	Power	+12V for SFF-TA-1009 power
B2	+12V	Power	+12V for SFF-TA-1009 power
B3	+12V	Power	+12V for SFF-TA-1009 power
B4	+12V	Power	+12V for SFF-TA-1009 power
B5	+12V	Power	+12V for SFF-TA-1009 power
B6	+12V	Power	+12V for SFF-TA-1009 power
B7	MFG	NC	Manufacturing mode
B8	RFU	NC	Reserved
B9	DualPortEn#	Output	Dual-port Enable
B10	PERST#	Output	Fundamental reset (if Single Port mode enabled, first X2 port)
B11	+3.3 Vaux	Power	3.3 V auxiliary power
B12	PWRDIS	Output	Power disable
B13	Ground	Ground	Ground
B14	REFCLK-	Diff-Pair	Reference clock (if dual-port enabled, first X2 port)
B15	REFCLK+	Diff-Pair	Reference clock (if dual-port enabled, first X2 port)
B16	Ground	Ground	Ground
B17	E3.S TX n0	Diff-Pair	Transmitter differential pair, E3.S Lane 0
B18	E3.S TX p0	Diff-Pair	Transmitter differential pair, E3.S Lane 0
B19	Ground	Ground	Ground
B20	E3.S TX n1	Diff-Pair	Transmitter differential pair, E3.S Lane 1
B21	E3.S TX p1	Diff-Pair	Transmitter differential pair, E3.S Lane 1
B22	Ground	Ground	Ground
B23	E3.S TX n2	Diff-Pair	Transmitter differential pair, E3.S Lane 2
B24	E3.S TX p2	Diff-Pair	Transmitter differential pair, E3.S Lane 2
B25	Ground	Ground	Ground
B26	E3.S TX n3	Diff-Pair	Transmitter differential pair, E3.S Lane 3
B27	E3.S TX p3	Diff-Pair	Transmitter differential pair, E3.S Lane 3
B28	Ground	Ground	Ground

### 9.5.3 Power

The E3.S connector supports a 12V power source to power the device. It also supports a 3.3Vaux power source to provide power to manage sideband communication.

All power and grounds shall be supported by the implemented connector on the host and the implemented card edge on the device.

There are no power sequencing requirements for 12V and 3.3Vaux.

These two voltages are independent from each other.

- If 12V is present and PWRDIS is de-asserted, regardless of the presence of 3.3Vaux, then the PCIe interface shall be functional.
- If 3.3Vaux is not present, 12V is present, and SMRST# is de-asserted, then the SMBus Basic interface may be functional.
- If 3.3Vaux is present but 12V is not present, then the SMBus Basic interface should be functional.
- For more details, refer to specification SFF-TA-1009 available on [www.snia.org](http://www.snia.org).

## 10. About FIPS

The Federal Information Processing Standard (FIPS) Publication 140-3 is a U.S. Government Computer Security Standard used to accredit cryptographic modules. It is titled 'Security Requirements for Cryptographic Modules (FIPS PUB 140-3)' and is issued by the National Institute of Standards and Technology (NIST).

### 10.1 Purpose

This standard specifies the security requirements that will be satisfied by a cryptographic module utilized within a security system protecting sensitive but unclassified information. The standard provides four increasing, qualitative levels of security: Level 1, Level 2, Level 3 and Level 4. These levels are intended to cover the wide range of potential applications and environments in which cryptographic modules may be employed.

### 10.2 Validation Program

Products that claim conformance to this standard are validated by the Cryptographic Module Validation Program (CMVP) which is a joint effort between National Institute of Standards and Technology (NIST) and the Communications Security Establishment (CSE) of the Government of Canada. Products validated as conforming to FIPS 140-3 are accepted by the Federal agencies of both countries for the protection of sensitive information (United States) or Designated Information (Canada).

In the CMVP, vendors of cryptographic modules use independent, accredited testing laboratories to have their modules tested. National Voluntary Laboratory Accreditation Program (NVLAP) accredited laboratories perform cryptographic module compliance/conformance testing.

### 10.3 Seagate Enterprise SED

The SEDs described in this Product Manual are planned to be validated by CMVP and thoroughly tested by a NVLAP accredited lab to satisfy FIPS 140-3 Level 2 requirements. In order to operate in FIPS Approved Mode of Operation, these SEDs require security initialization. For more information, refer to *Security Rules* section in the *Security Policy* document uploaded on the NIST website (when it becomes available). For product certification status visit <https://csrc.nist.gov/projects/cryptographic-module-validation-program/validated-modules/search>.

## 10.4 Security Level 2

Security Level 2 enhances the physical security mechanisms of a Security Level 1 cryptographic module by adding the requirement for tamper-evidence, which includes the use of tamper-evident coatings or seals on removable covers of the module.

Tamper evident coatings or seals are placed on a cryptographic module so that the coating or seal must be broken to attain physical access to the critical security parameters (CSP) within the module.

Tamper-evident seals (example shown in [Figure 5, Example of FIPS tamper evidence labels, on page 47](#)) are placed on covers to protect against unauthorized physical access.

In addition Security Level 2 requires, at a minimum, role-based authentication in which a cryptographic module authenticates the authorization of an operator to assume a specific role and perform a corresponding set of services.

**Figure 5 Example of FIPS tamper evidence labels**



**NOTE** Image is for reference only, does not represent actual drive.

# 11. About self-encrypting drives

Self-encrypting drives (SEDs) offer encryption and security services for the protection of stored data, commonly known as *protection of data at rest*. These drives are compliant with the Trusted Computing Group (TCG) Opal Storage Specifications as detailed in this section.

The Trusted Computing Group (TCG) is an organization sponsored and operated by companies in the computer, storage and digital communications industry. The Seagate SED models comply with the standards published by the TCG.

To use the security features in the drive, the host must be capable of constructing and issuing the following two NVMe commands:

- Security Send
- Security Receive

These commands are used to convey the TCG protocol to and from the drive in the appropriate command payloads.

## 11.1 Data encryption

Encrypting drives use one in-line encryption engine for each port, employing AES-256 data encryption in XEX-based tweaked-codebook mode with ciphertext stealing (XTS) to encrypt all data prior to being written on the media and to decrypt all data as it is read from the media. The encryption engines are always in operation and cannot be disabled.

The 32-byte Data Encryption Key (DEK) is a random number which is generated by the drive, never leaves the drive, and is inaccessible to the host system. The DEK is itself encrypted when it is stored on the media and when it is in volatile temporary storage (DRAM) external to the encryption engine. A unique data encryption key is used for each of the drive's possible 9 data bands (see [Section 11.5 Data bands](#)).

## 11.2 Controlled access

The drive has two security providers (SPs) called the "Admin SP" and the "Locking SP." These act as gatekeepers to the drive security services. Security-related commands will not be accepted unless they also supply the correct credentials to prove the requester is authorized to perform the command.

### 11.2.1 Admin SP

The Admin SP allows the drive's owner to enable or disable firmware download operations (see [Section 11.4 Drive locking](#)). Access to the Admin SP is available using the SID (Secure ID) password or the MSID (Manufacturers Secure ID) password.

### 11.2.2 Locking SP

The Locking SP controls read/write access to the media and the cryptographic erase feature. Access to the Locking SP is available using the BandMasterX or EraseMaster passwords. Since the drive owner can define up to 9 data bands on the drive, each data band has its own password called BandMasterX where X is the number of the data band (0 through 8).



### 11.2.3 Default password

When the drive is shipped from the factory, all passwords are set to the value of MSID. This 32-byte random value can only be read by the host electronically over the interface. After receipt of the drive, it is the responsibility of the owner to use the default MSID password as the authority to change all other passwords to unique owner-specified values.

## 11.3 Random number generator (RNG)

The drive has a 32-byte hardware RNG that it uses to derive encryption keys or, if requested to do so, to provide random numbers to the host for system use, including using these numbers as Authentication Keys (passwords) for the drive's Admin and Locking SPs.

## 11.4 Drive locking

In addition to changing the passwords, as described in [Section 11.2.3 Default password](#), the owner should also set the data access controls for the individual bands.

The variable *LockOnReset* should be set to *PowerCycle* to ensure that the data bands will be locked if power is lost. In addition *ReadLockEnabled* and *WriteLockEnabled* must be set to true in the locking table in order for the bands *LockOnReset* setting of *PowerCycle* to actually lock access to the band when a *PowerCycle* event occurs. This scenario occurs if the drive is removed from its cabinet. The drive will not honor any data READ or WRITE requests until the bands have been unlocked. This prevents the user data from being accessed without the appropriate credentials when the drive has been removed from its cabinet and installed in another system.

When the drive is shipped from the factory, the firmware download port is unlocked allowing the drive to accept any attempt to download new firmware. The drive owner must use the SID credential to lock the firmware download port before firmware updates will be rejected.

## 11.5 Data bands

When shipped from the factory, the drive is configured with a single data band called Band 0 (also known as the Global Data Band) which comprises LBA 0 through LBA max. The host may allocate Band1 by specifying a start LBA and an LBA range. The real estate for this band is taken from the Global Band. An additional 7 Data Bands may be defined in a similar way (Band2 through Band8) but before these bands can be allocated LBA space, they must first be individually enabled using the *EraseMaster* password.

Data bands cannot overlap but they can be sequential with one band ending at LBA (x) and the next beginning at LBA (x+1).

Each data band has its own drive-generated encryption key and its own user-supplied password. The host may change the Encryption Key or the password when required. The bands shall be aligned to 4KB LBA boundaries.

## 11.6 Cryptographic erase

A significant feature of SED drives is the ability to perform a cryptographic erase. This involves the host telling the drive to change the data encryption key for a particular band. Once changed, the data is no longer recoverable since it was written with one key and will be read using a different key. Since the drive overwrites the old key with the new one, and keeps no history of key changes, the user data can never be recovered. This creates an instantaneous data erase and is very useful if the drive is to be scrapped or redispositioned. Erased sectors are unmapped and return all zeros if read.

## 11.7 Authenticated firmware download

In addition to providing a locking mechanism to prevent unwanted firmware download attempts, the drive also only accepts download files which have been cryptographically signed by the appropriate Seagate Design Center.

Three conditions must be met before the drive will allow the download operation:

1. The download must be an SED file. A standard (base) drive (non-SED) file will be rejected.
2. The download file must be digitally signed and authenticated.
3. As with a non-SED drive, the download file must pass the acceptance criteria for the drive. For example it must be applicable to the correct drive model, and have compatible revision and customer status.

## 11.8 Power requirements

The standard drive models and the SED drive models have identical hardware, however the security and encryption portion of the drive controller ASIC is enabled and functional in the SED models. This represents a small additional drain on the 12V supply of about 150mW in power consumption. See the tables in [Section 9.2 Power consumption](#) for power requirements on the standard (non-SED) drive models.

## 11.9 Supported commands

The SED models support the following two commands in addition to the commands supported by the standard (non-SED) models as listed in [Table 23, NVMe Admin Commands](#).

- Security Send
- Security Receive

## 11.10 Sanitize - Cryptographic Erase

This command cryptographically erases all user data on the drive by destroying the current data encryption key and replacing it with a new data encryption key randomly generated by the drive. The Crypto Erase Sanitize operation is NVMe Command Identifier 84h and selecting the Sanitize Action (SANACT) code 100b (Start a Crypto Erase sanitize operation.).

## **11.11 RevertSP**

SED models support the RevertSP feature which erases all data in all bands on the device and returns the contents of all SPs (Security Providers) on the device to their original factory state. In order to execute the RevertSP method the unique PSID (Physical Secure ID) printed on the drive label must be provided. PSID is not electronically accessible and can only be manually read from the drive label or scanned in using the 2D barcode.

## 12. Installation

Nytro 5060 NVMe SSD installation is a plug-and-play process. There are no jumpers on the drive.

E3.S drives are designed to be used in a host system that provides a PCIe-compatible backplane with bays designed to accommodate the drive. In such systems, the host system typically provides a carrier or tray into which the drive must be mounted. Mount the drive to the carrier or tray provided by the host system. If screws are needed use M.3 x 0.5 metric screws. When tightening the screws, use a maximum torque of 4.5 in-lb +/- 0.45 in-lb. Do not over-tighten or force the screws.

**NOTE** E3.S drives are designed to be attached to the host system without I/O or power cables. If the intent is to use the drive in a non-backplane host system, connecting the drive using high-quality cables is acceptable as long as the I/O cable length does not exceed 1 meter (3.2 feet).

Slide the carrier or tray into the appropriate bay in the host system using the instructions provided by the host system. This connects the drive directly to the system's compatible connector. The connector is normally located on a PCIe-compatible backpanel. See [Section 13.5 Signal characteristics](#) for additional information about these connectors.

Power is supplied through the connector

The drive is shipped from the factory low-level formatted in 512-byte logical blocks and a single namespace using all logical blocks. Reformatting the drive is only required if the application requires a different logical block size..

**Figure 6 Physical interface**

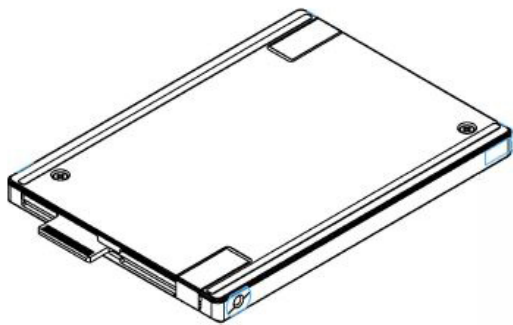

### 12.1 Cooling

Cabinet cooling must be designed by the customer so that the temperature of the drive will not exceed temperature conditions specified in [Section 9.3.1 Temperature](#).

The rack, cabinet, or drawer environment for the drive must provide heat removal from the assembly. The system designer should confirm that adequate heat removal is provided using the temperature measurement guidelines described in [Section 9.3.1 Temperature](#).

Forced air flow may be required to keep temperatures at or below the temperatures specified in [Section 9.3.1 Temperature](#) in which case the drive should be oriented, or air flow directed, so that the least amount of air flow resistance is created while providing air flow. Also, the shortest possible path between the air inlet and exit should be chosen to minimize the travel length of air heated by the drive and other heat sources within the rack, cabinet, or drawer environment.

If forced air is determined to be necessary, possible air-flow patterns are shown in [Figure 7, Air Flow](#). The air-flow patterns are created by one or more fans, either forcing or drawing air as shown in the illustrations. Conduction, convection, or other forced air-flow patterns are acceptable as long as the temperature measurement guidelines of [Section 9.3.1 Temperature](#) are met.

**Figure 7 Air Flow**

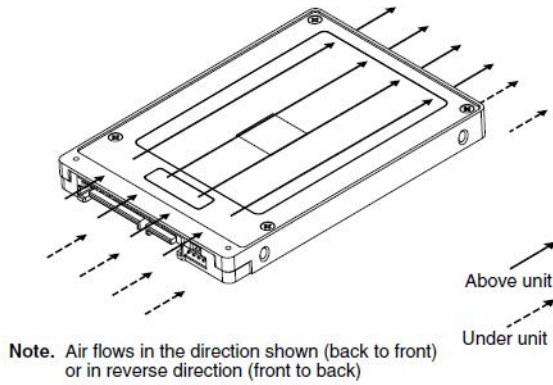

**NOTE** Image may not represent actual product, for reference only.

## 13. NVMe Interface requirements

This section lists the NVMe-specific features supported by Nytro 5060 SSDs.

### 13.1 Get/Set Features

The following table lists Get Features and Set Feature Identifiers.

**Table 21 - Nytro 5060 SSDs Support the Following Get/Set Features**

Feature Identifier	M/O	Command	Supported
01h	M	Arbitration	Yes
02h	M	Power Management	Yes
03h	O	LBA Range Type	No
04h	M	Temperature Threshold	Yes
05h	M	(Time Limited) Error Recovery	Yes
06h	O	Volatile Write Cache	Yes
07h	M	Number of Queues	Yes
08h	M	Interrupt Coalescing	Yes
09h	M	Interrupt Vector Configuration	Yes
0Ah	M	Write Atomicity	Yes
0Bh	M	Asynchronous Event Configuration	Yes
0Ch	O	Autonomous Power State Transition	No
0Dh	O	Host Memory Buffer	No
0Eh	O	Timestamp	Yes
0Fh	O	Keep Alive Timer	No
10h	O	Host Controlled Thermal Management	No
11h	O	Non-Operational Power State Config	No
15h	O	LBA Status Information Report Interval	No
16h	O	Host Behavior Support	No
17h	O	Sanitize Config	Yes
18h	O	Endurance Group Event Configuration	No
7Eh	O	Controller Metadata	Yes
7Fh	O	Namespace Metadata	Yes
80h	O	Software Progress Marker	No
81h	O	Host Identifier	Yes
82h	O	Reservation Notification Mask	Yes
83h	O	Reservation Persistence	Yes
84h	O	Namespace Write Protection Config	No

## 13.2 Log Pages

The following table lists the NVMe log pages supported by Nytro 5060 SSDs.

**Table 22 - NVMe Log Pages Supported**

Log Page Identifier	M/O	Command	Supported
01h	M	Error Information	Yes
02h	M	SMART / Health Information	Yes
03h	M	Firmware Slot Information	Yes
04h	O	Changed Namespace List	Yes
05h	O	Commands Supported and Effects Log	Yes
06h	O	Device Self-Test Log	Yes
07h	O	Telemetry Host-Initiated	Yes
08h	O	Telemetry Controlled-Initiated	Yes
0Dh	O	Persistent Event Log	Yes
80h	O	Reservation Notification	Yes
81h	O	Sanitize Status	Yes

## 13.3 Dual port support

Nytro 5060H models support operation in dual port mode. In this mode, the PCIe interface is bifurcated into two ports with two PCIe lanes each. Each port can perform independent port clocking, and can run at any supported link rate. The supported link rates are 16, 8, 5, or 2.5GT/s.

## 13.4 NVMe Commands Supported

The following table lists the NVMe commands supported by Nytro 5060 SSD drives. For details about command fields definition and options, refer to the NVMe Express 2.0 specification available at [nvmexpress.org](http://nvmexpress.org).

**Table 23 - NVMe Admin Commands**

Admin Commands Supported			
Command Identifier	M/O	Command	Supported
00h	M	Delete I/O Submission Queue	Yes
01h	M	Create I/O Submission Queue	Yes
02h	M	Get Log Page	Yes
04h	M	Delete I/O Completion Queue	Yes
05h	M	Create I/O Completion Queue	Yes
06h	M	Identify	Yes
08h	M	Abort	Yes
09h	M	Set Features	Yes

**Table 23 - NVMe Admin Commands (continued)**

0Ah	M	Get Features	Yes
0Ch	M	Async Event Request	Yes
0Dh	O	Namespace Management	Yes
10h	M	Firmware Commit	Yes
11h	M	Firmware Image Download	Yes
14h	M	Device Self-Test	Yes
15h	O	Namespace Attachment	Yes
1Dh	O	NVMe-MI Send	Yes
1Eh	O	NVMe-MI Receive	Yes
7Ch	O	Doorbell Buffer Config	No
80h	O	Format NVM	Yes
81h	O	Security Send	Yes
82h	O	Security Receive	Yes
84h	O	Sanitize	Yes

**Table 24 - NVMe I/O Commands**

I/O commands supported			
Command Identifier	M/O	Command	Supported
00h	M	Flush	Yes
01h	M	Write	Yes
02h	M	Read	Yes
04h	O	Write Uncorrectable	Yes
05h	O	Compare	Yes
08h	O	Write Zeros	Yes
09h	O	Dataset Management - Trim	Yes
0Ch	O	Verify	Yes
0Dh	O	Reservation Register	Yes
0Eh	O	Reservation Report	Yes
11h	O	Reservation Acquire	Yes
15h	O	Reservation Release	Yes



### 13.4.1 Identify Controller

The following table lists the Identify Controller data structure (CNS 01h) bytes 63:24 that the drive returns to the host. Bytes 24 through 63 (MN field) reflect the model of drive in ASCII.

**Table 25 Nytro 5060H - Identify Controller Data**

Bytes	24	25	26	27	28	29	30	31	32	33	34	35	36	37	38	39	...	63
XP1600LE70006	58	50	31	36	30	30	4C	45	37	30	30	30	36	20	20	20	...	20
XP3200LE70006	58	50	33	32	30	30	4C	45	37	30	30	30	36	20	20	20	...	20
XP6400LE70006	58	50	36	34	30	30	4C	45	37	30	30	30	36	20	20	20	...	20
XP12800LE70006	58	50	31	32	38	30	30	4C	45	37	30	30	30	36	20	20	...	20
XP25600LE70006	58	50	32	35	36	30	30	4C	45	37	30	30	30	36	20	20	...	20
XP1600LE70016	58	50	31	36	30	30	4C	45	37	30	30	31	36	20	20	20	...	20
XP3200LE70016	58	50	33	32	30	30	4C	45	37	30	30	31	36	20	20	20	...	20
XP6400LE70016	58	50	36	34	30	30	4C	45	37	30	30	31	36	20	20	20	...	20
XP12800LE70016	58	50	31	32	38	30	30	4C	45	37	30	30	31	36	20	20	...	20
XP25600LE70016	58	50	32	35	36	30	30	4C	45	37	30	30	31	36	20	20	...	20
XP1600LE70026	58	50	31	36	30	30	4C	45	37	30	30	32	36	20	20	20	...	20
XP3200LE70026	58	50	33	32	30	30	4C	45	37	30	30	32	36	20	20	20	...	20
XP6400LE70026	58	50	36	34	30	30	4C	45	37	30	30	32	36	20	20	20	...	20
XP12800LE70026	58	50	31	32	38	30	30	4C	45	37	30	30	32	36	20	20	...	20
XP25600LE70026	58	50	32	35	36	30	30	4C	45	37	30	30	32	36	20	20	...	20
XP1920SE70006	58	50	31	39	32	30	53	45	37	30	30	30	36	20	20	20	...	20
XP3840SE70006	58	50	33	38	34	30	53	45	37	30	30	30	36	20	20	20	...	20
XP7680SE70006	58	50	37	36	38	30	53	45	37	30	30	30	36	20	20	20	...	20
XP15360SE70006	58	50	31	35	33	36	30	53	45	37	30	30	30	36	20	20	...	20
XP30720SE70006	58	50	33	30	37	32	30	53	45	37	30	30	30	36	20	20	...	20
XP1920SE70016	58	50	31	39	32	30	53	45	37	30	30	31	36	20	20	20	...	20
XP3840SE70016	58	50	33	38	34	30	53	45	37	30	30	31	36	20	20	20	...	20
XP7680SE70016	58	50	37	36	38	30	53	45	37	30	30	31	36	20	20	20	...	20
XP15360SE70016	58	50	31	35	33	36	30	53	45	37	30	30	31	36	20	20	...	20
XP30720SE70016	58	50	33	30	37	32	30	53	45	37	30	30	31	36	20	20	...	20
XP1920SE70026	58	50	31	39	32	30	53	45	37	30	30	32	36	20	20	20	...	20
XP3840SE70026	58	50	33	38	34	30	53	45	37	30	30	32	36	20	20	20	...	20
XP7680SE70026	58	50	37	36	38	30	53	45	37	30	30	32	36	20	20	20	...	20
XP15360SE70026	58	50	31	35	33	36	30	53	45	37	30	30	32	36	20	20	...	20
XP30720SE70026	58	50	33	30	37	32	30	53	45	37	30	30	32	36	20	20	...	20

**Table 26 Nytro 5060S - Identify Controller Data**

Bytes	24	25	26	27	28	29	30	31	32	33	34	35	36	37	38	39	...	63
XP1600LE70036	58	50	31	36	30	30	4C	45	37	30	30	33	36	20	20	20	...	20
XP3200LE70036	58	50	33	32	30	30	4C	45	37	30	30	33	36	20	20	20	...	20
XP6400LE70036	58	50	36	34	30	30	4C	45	37	30	30	33	36	20	20	20	...	20
XP12800LE70036	58	50	31	32	38	30	30	4C	45	37	30	30	33	36	20	20	...	20
XP25600LE70036	58	50	32	35	36	30	30	4C	45	37	30	30	33	36	20	20	...	20
XP1600LE70046	58	50	31	36	30	30	4C	45	37	30	30	34	36	20	20	20	...	20
XP3200LE70046	58	50	33	32	30	30	4C	45	37	30	30	34	36	20	20	20	...	20
XP6400LE70046	58	50	36	34	30	30	4C	45	37	30	30	34	36	20	20	20	...	20
XP12800LE70046	58	50	31	32	38	30	30	4C	45	37	30	30	34	36	20	20	...	20
XP25600LE70046	58	50	32	35	36	30	30	4C	45	37	30	30	34	36	20	20	...	20
XP1600LE70056	58	50	31	36	30	30	4C	45	37	30	30	35	36	20	20	20	...	20
XP3200LE70056	58	50	33	32	30	30	4C	45	37	30	30	35	36	20	20	20	...	20
XP6400LE70056	58	50	36	34	30	30	4C	45	37	30	30	35	36	20	20	20	...	20
XP12800LE70056	58	50	31	32	38	30	30	4C	45	37	30	30	35	36	20	20	...	20
XP25600LE70056	58	50	32	35	36	30	30	4C	45	37	30	30	35	36	20	20	...	20
XP1920SE70036	58	50	31	39	32	30	53	45	37	30	30	33	36	20	20	20	...	20
XP3840SE70036	58	50	33	38	34	30	53	45	37	30	30	33	36	20	20	20	...	20
XP7680SE70036	58	50	37	36	38	30	53	45	37	30	30	33	36	20	20	20	...	20
XP15360SE70036	58	50	31	35	33	36	30	53	45	37	30	30	33	36	20	20	...	20
XP30720SE70036	58	50	33	30	37	32	30	53	45	37	30	30	33	36	20	20	...	20
XP1920SE70046	58	50	31	39	32	30	53	45	37	30	30	34	36	20	20	20	...	20
XP3840SE70046	58	50	33	38	34	30	53	45	37	30	30	34	36	20	20	20	...	20
XP7680SE70046	58	50	37	36	38	30	53	45	37	30	30	34	36	20	20	20	...	20
XP15360SE70046	58	50	31	35	33	36	30	53	45	37	30	30	34	36	20	20	...	20
XP30720SE70046	58	50	33	30	37	32	30	53	45	37	30	30	34	36	20	20	...	20
XP1920SE70056	58	50	31	39	32	30	53	45	37	30	30	35	36	20	20	20	...	20
XP3840SE70056	58	50	33	38	34	30	53	45	37	30	30	35	36	20	20	20	...	20
XP7680SE70056	58	50	37	36	38	30	53	45	37	30	30	35	36	20	20	20	...	20
XP15360SE70056	58	50	31	35	33	36	30	53	45	37	30	30	35	36	20	20	...	20
XP30720SE70056	58	50	33	30	37	32	30	53	45	37	30	30	35	36	20	20	...	20

### 13.4.2 Set Features Data

The Get Features command provides a way for the drive to report its operating parameters to the host. The drive maintains four sets of feature attributes:

#### 1. Current values

Current values are volatile values being used by the drive to control its operation. A Set Features command can be used to change the values identified as changeable values. Originally, current values are installed from saved or default values after a reset.

## 2. Default values

Default values are hard-coded in the drive firmware stored in flash E-PROM (nonvolatile memory) on the drive's PCB. These default values can be changed only by downloading a complete set of new firmware into the flash E-PROM. A host can request and receive from the drive a list of default values and use those in a Set Features command to set up new current and saved values, where the values are changeable.

## 3. Saved values

Saved values are stored on the drive media using a Set Features command. Only attribute values that are allowed to be changed can be changed by this method. Attributes in the saved values list that are not changeable by the Set Features command get their values from default values storage.

When power is applied to the drive, it takes saved values from the media and stores them as current values in volatile memory. It is not possible to change the current values (or the saved values) with a Set Features command before the drive is "ready." An attempt to do so results in a "Check Condition" status.

On drives requiring unique saved values, the required unique saved values are stored into the saved values storage location on the media prior to shipping the drive. Some drives may have unique firmware with unique default values also.

On standard OEM drives, the saved values are taken from the default values list and stored into the saved values storage location on the media prior to shipping.

## 4. Supported Capabilities

Supported Capabilities returns the capabilities supported for this Feature Identifier. The capabilities supported are returned in Dword 0 of the completion entry of the Get Features command.

## 13.5 Signal characteristics

This section describes the electrical signal characteristics of the drive's input and output signals. See [Table 20, Connector E3.S Pin Assignment and Descriptions](#) for signal type and signal name information.

### 13.5.1 ACTIVITY# signal

The ACTIVITY# signal is managed by the drive as indicated in the table below.

**Table 27 - ACTIVITY LED Out conditions**

Normal command activity	Green LED status
Drive stopped, not ready, and no activity	Off
Drive stopped, not ready, and activity (command executing)	Blinks (50ms on, 50ms off)
Drive started, ready, and no activity	Off
Drive started, ready, and activity (command executing)	On
FORMAT UNIT in progress	Slower blinks (0.25 seconds on, 0.25 seconds off)

### 13.5.2 Fault/Identity LED (amber/blue bi-color)

The Fault/Identify LED indicates when a device is in a fault condition or when the host

needs to identify the device in a chassis.

**Table 28 - LED and device state per function for amber/blue LED**

<b>LED signal state</b>	<b>Amber LED state</b>	<b>Blue LED state</b>
Asserted (driven high)	On	Off
De-asserted (driven low)	Off	On
High impedance (not driven)	Off	Off

For more details refer to SFF-TA-1008 and SFF-TA-1009 available on [www.snia.com](http://www.snia.com).



**Seagate Technology LLC**

*AMERICAS Seagate Technology LLC 47488 Kato Road, Fremont, California 94538, United States, 510-661-1000*

*ASIA/PACIFIC Seagate Singapore International Headquarters Pte. Ltd. 7000 Ang Mo Kio Avenue 5, Singapore 569877, 65-6485-3888*

*EUROPE, MIDDLE EAST AND AFRICA Seagate Technology (Netherlands) B.V. Koolhovenlaan 1, 1119 NB Schiphol-Rijk, Netherlands, 31-20-316-7300*

**Publication Number: 208464400, Rev A**

**November 2024**