

A decorative graphic on the left side of the page, featuring a large dashed circle, a solid blue circle, and several overlapping curved lines in blue and grey.

Product Manual

# Momentum® 5400 FDE.4 SATA

**ST9500327AS**

**ST9320327AS**

**ST9250317AS**

**ST9160317AS**

**ST9120317AS**

**ST980314AS**

100562041  
Rev. C  
November 2010

© 2010, Seagate Technology LLC All rights reserved.  
Publication number: 100562041, Rev. C November 2010

Seagate, Seagate Technology and the Wave logo are registered trademarks of Seagate Technology LLC in the United States and/or other countries. Momentus and SeaTools are either trademarks or registered trademarks of Seagate Technology LLC or one of its affiliated companies in the United States and/or other countries. All other trademarks or registered trademarks are the property of their respective owners.

No part of this publication may be reproduced in any form without written permission of Seagate Technology LLC. Call 877-PUB-TEK1(877-782-8351) to request permission.

One gigabyte, or GB, equals one billion bytes and one terabyte, or TB, equals one trillion bytes. Your computer's operating system may use a different standard of measurement and report a lower capacity. In addition, some of the listed capacity is used for formatting and other functions, and thus will not be available for data storage. Seagate reserves the right to change, without notice, product offerings or specifications.

# Contents

<b>1.0</b>	<b>Introduction</b>	<b>1</b>
1.1	System requirements	1
1.2	About Momentus 5400 FDE.4 SATA disk drives	2
1.2.1	Drive state upon shipment	3
<b>2.0</b>	<b>Drive specifications</b>	<b>4</b>
2.1	Specification summary table	4
2.2	Formatted capacity	6
2.2.1	LBA mode	6
2.3	Default logical geometry	6
2.4	Physical organization	7
2.5	Recording and interface technology	7
2.6	Physical characteristics	7
2.7	Seek time	8
2.8	Start/stop times	8
2.9	Power specifications	9
2.9.1	Power consumption	9
2.9.2	Deferred spinup	10
2.9.3	Conducted noise	10
2.9.4	Voltage tolerance	10
2.9.5	Power-management modes	11
2.10	Environmental specifications	12
2.10.1	Ambient temperature	12
2.10.2	Temperature gradient	12
2.10.3	Humidity	12
2.10.4	Altitude	12
2.10.5	Shock	13
2.10.6	Vibration	13
2.11	Acoustics	14
2.12	Electromagnetic immunity	14
2.13	Reliability	15
2.14	Agency certification	15
2.14.1	Safety certification	15
2.14.2	Electromagnetic compatibility	15
2.14.3	FCC verification	16
2.15	Environmental protection	17
2.15.1	European Union Restriction of Hazardous Substances (RoHS)	17
2.15.2	China Restriction of Hazardous Substances (RoHS) Directive	17
2.16	Corrosive environment	17
<b>3.0</b>	<b>Configuring and mounting the drive</b>	<b>18</b>
3.1	Handling and static-discharge precautions	18
3.2	Configuring the drive	19
3.3	Serial ATA cables and connectors	19
3.4	Drive mounting	20
3.5	Drive integration	22
3.5.1	Drive installation	23
3.5.2	Consumer usage	23
3.6	Security Erase--ATA security commands	23
3.6.1	Secure Erase procedure	23
3.6.2	Drive State after Secure Erase	24
<b>4.0</b>	<b>Serial ATA interface</b>	<b>25</b>
4.1	Hot-Plug compatibility	25

4.2	Serial ATA device plug connector pin definitions . . . . .	25
4.2.1	ATA Security policy exceptions . . . . .	26
4.2.2	DriveTrust Mode support . . . . .	28
4.2.3	Full Disk Encryption support. . . . .	29
4.2.4	Supported ATA commands . . . . .	30
4.2.5	Identify Device command . . . . .	33
4.2.6	Set Features command . . . . .	37
4.2.7	S.M.A.R.T. commands . . . . .	38
<b>5.0</b>	<b>Compatibility summary . . . . .</b>	<b>39</b>
5.1	Installation considerations . . . . .	39
5.2	System Compatibility using WIndows XP SP2. . . . .	39
5.2.1	BIOS versions tested in ATA Security mode . . . . .	39
5.2.2	DriveTrust compatibility verification . . . . .	42
5.3	Operating system versions tested . . . . .	46
5.4	Compatibility test configurations . . . . .	46
<b>6.0</b>	<b>Seagate Technology support services . . . . .</b>	<b>47</b>

## List of Figures

Figure 1.	Typical +5V only startup and operation current profile . . . . .	10
Figure 2.	Serial ATA connectors . . . . .	19
Figure 3.	Attaching SATA cabling . . . . .	19
Figure 4.	Mounting dimensions . . . . .	21
Figure 5.	Momentus 5400 FDE.4 SATA drive label example . . . . .	22



## 1.0 Introduction

---

This manual describes the functional, mechanical and interface specifications for the following Seagate Momentus® 5400 FDE.4 SATA model drives:

ST9500327AS	ST9160317AS
ST9320327AS	ST9120317AS
ST9250317AS	ST980314AS

These drives provide the following key features:

- DriveTrust technology including:
  - Hardware-based Full Disk Encryption (FDE)
  - DriveTrust security interface and ATA security interface
  - Integrates with standard security software packages to provide features such as: Pre-boot authentication and initialization using the drive's secure partition and DriveTrust API
- 5400-RPM spindle speed
- 8-Mbyte buffer
- Quiet operation. Fluid Dynamic Bearing (FDB) motor.
- High instantaneous (burst) data transfer rates (up to 100 Mbytes per second) using Ultra DMA mode 6.
- State-of-the-art cache and on-the-fly error-correction algorithms.
- Full-track multiple-sector transfer capability without local processor intervention.
- 1000 Gs nonoperating shock and 350 Gs operating shock.
- SeaTools™ diagnostic software performs a drive self-test that eliminates unnecessary drive returns.
- Support for S.M.A.R.T. drive monitoring and reporting.
- Support for Read Multiple and Write Multiple commands.

### 1.1 System requirements

The following hardware and software is required to use these drives.

Host system requirements:

- Windows XP with Service Pack 2 (or later) when utilizing the Windows DriveTrust API.
- System/BIOS that supports ATA Security commands.

## 1.2 About Momentus 5400 FDE.4 SATA disk drives

The Momentus 5400 FDE.4 SATA drives contain DriveTrust technology providing Full Disk Encryption (FDE) using proven Advanced Encryption Standard (AES) data encryption and decryption.

You can elect to use Momentus 5400 FDE.4 SATA drives in one of two different security modes:

1. ATA Security mode (available on all models documented in this manual)

To operate in ATA Security mode, you only need a host system and operating system that supports the existing ATA Security Command Set. The drive is shipped to operating in this mode, ready to use. All models documented in this manual may operate in this mode.

2. DriveTrust Security mode

To enable a robust enterprise-level security and management policy, you may elect to operate in DriveTrust Security mode. To do so, you will need to use a third-party security application to manage the DriveTrust features. Please contact your system or software provider for more details.

Refer to the table below to determine which mode is best for your particular solution.

**Table 1: Security feature matrix**

			ATA Security mode	DriveTrust mode
Feature	Non-FDE drive without ATA Security enabled	Non-FDE drive with ATA Security enabled	FDE drive with ATA Security enabled	FDE drive operating in DriveTrust mode via third-party software
Password required to unlock	No	Yes	Yes	Yes
Full Disk Encryption	No	No	Yes	Yes
At speed encryption	No	No	Yes	Yes
Passwords stored securely	No	Yes	Yes	Yes
Quick erase	No	No	Yes	Yes
Preboot authentication	No	No	No	Yes
Master/User passwords	No	No	No	Yes

### FDE drive feature list

- Automatically encrypts (and decrypts) all data on the drive
- Operations are performed with no measurable performance loss
- All user data is encrypted on write operations and decrypted on read operations

### FDE benefits

- Drive-level protection of data
- Drives that are stolen, taken out of service, or re-purposed remain fully protected
- Near instantaneous disposal and re-purposing of the drive (ensures that data from previous user is not accessible by the new drive owner)
- Able to be deployed within a trusted computing environment

The drive encrypts every write operation and decrypts every read operation without user intervention. The encryption and decryption is done on the drive itself, so there is a near-zero performance impact when the drive writes and reads data. The performance-optimized encryption and decryption engine performs at the SATA interface speed.

The purpose of full disk encryption on the drive is to protect the data stored on the drive in the event that the host system is lost or stolen. This data at rest protection assures the system owner that if their system is lost or stolen, their data will not be accessible without the correct credentials.

**Note.** The system reauthenticates the user on powerup and when awakening from sleep mode. It is not necessary to power down to ensure that the system reauthenticates the user.



Having the encryption/decryption on the drive also provides the highest level of security for data because all data, including the boot sector bytes, operating system, temp and even the swap files are encrypted at the drive level.

### **1.2.1 Drive state upon shipment**

Upon shipment from the Seagate factory, the ATA Security Interface is enabled and functioning. This is referred to as operating in ATA Security mode. The following is the detailed state of the drive upon shipment.

- Full Disk Encryption is active and functioning. All user data is encrypted on write and decrypted on read.
- The user interface to the drive is active and all read and write commands are allowed.
- The ATA user password is null (no value).
- The ATA master password is set to the Security ID (SID).
- ATA Security is set to the unlocked state. No password is required to access the drive.

Momentum 5400 FDE.4 SATA drives may be integrated into the computer system in the same way you would integrate a non-FDE Momentum drive.

The encryption key is enabled and operational when the drive leaves the Seagate factory. No user id is required to access the drive, so the data on the drive is accessible to anyone possessing the drive.

## 2.0 Drive specifications

Unless otherwise noted, all specifications are measured under ambient conditions, at 25°C, and nominal power.

### 2.1 Specification summary table

The specifications listed in this table are for quick reference. For details on specification measurement or definition, see the appropriate section of this manual.

**Table 2: Drive specifications**

Drive specification	ST9500327AS	ST9320327AS	ST9250317AS	ST9160317AS	ST9120317AS	ST980314AS
Formatted Gbytes (512 bytes/sector)*	500	320	160	120	120	
Guaranteed sectors	976,773,168	625,142,448	488,397,168	312,581,808	234,441,648	156,301,488
Bytes per sector	512					
Physical read/write heads	4	3	2	2	1	1
Disks	2	2	1	1	1	1
Cache (Mbytes)	8					
Recording density in BPI (bits/inch max)	1490k					
Track density TPI (tracks/inch max)	265k					
Areal density (Gbits/inch <sup>2</sup> max)	394					
Spindle speed (RPM)	5400					
Internal transfer rate (Mbits/sec max)	1175					
I/O data transfer rate (Mbytes/sec max)	300					
ATA data-transfer modes supported	SATA 1.5/3.0, Serial ATA Revision 2.6 PIO modes 0–4 Multiword DMA modes 0–2 Ultra DMA modes 0–6					
Height (max)	9.5 +/- 0.2 mm (0.374 +/- .0079 inches)					
Width (max)	69.85 +/- 0.25 mm (2.75 +/- 0.0098 inches)					
Length (max)	100.33 +0.20 / -0.25 mm (3.957 +0.0079 / -0.0098 inches)					
Weight (typical)	98.8 grams (0.218 lb)		93.5 grams (0.206 lb)			
Average latency (msec)	5.6					
Power-on to ready (sec typical)	3.6					
Power-on to ready (sec max)	3.8					
Standby to ready (sec typical)	1.8					
Standby to ready (sec max)	2					

**Table 2: Drive specifications**

Drive specification	ST9500327AS	ST9320327AS	ST9250317AS	ST9160317AS	ST9120317AS	ST980314AS
Track-to-track seek time, read (msec typical)	1					
Average seek, read (msec typical)	14					
Full-stroke seek, read (msec max)	30					
Startup current, +5V (max)	1.0 amps					
Seek power (typical)	1.54 watts					
Read/write power (typical)	Read: 1.40 watts; Write: 1.78 watts					
Idle mode, low power (typical)	0.67 watts					
Standby mode	0.22 watts (typical)***					
Sleep mode	0.22 watts (typical)***					
Voltage tolerance (including noise)	+5V ± 5%					
Ambient temperature	0° to 60°C (operating), -40° to 70°C (nonoperating)					
Temperature gradient (°C per hour max)	20°C (operating) 35°C (nonoperating)					
Relative humidity	5% to 95% (operating) 5% to 95% (nonoperating)					
Relative humidity gradient	30% per hour max					
Wet bulb temperature (max)	37.7°C (operating) 40°C (nonoperating)					
Altitude, operating	-304.8 m to 3048 m (-1000 ft to 10,000+ ft)					
Altitude, nonoperating (meters below mean sea level, max)	-304.8 m to 12,192 m (-1000 ft to 40,000+ ft)					
Shock, operating (Gs max at 2 msec)	350					
Shock, nonoperating (Gs max at 2 msec)	800					
Shock, nonoperating (Gs max at 1 msec)	1,000					
Shock, nonoperating (Gs max at 0.5 msec)	600					
Vibration, operating	1.0 G (0 to peak, 5–500 Hz)					
Vibration, nonoperating	5 Gs (0 to peak, 10–500 Hz)					
Drive acoustics, sound power (bels)						
Idle**	2.4 (typical) 2.6 (max)					
Performance seek	2.6 (typical) 2.7 (max)					
Nonrecoverable read errors	1 per 10 <sup>14</sup> bits read					
Annualized Failure Rate (AFR)	<0.48%					
Load/Unload (U/UL) cycles						
25°C, 50% relative humidity	600,000 software-controlled power on/off cycles 20,000 hard power on/off cycles					
32°C, 80% relative humidity 5°C, 80% relative humidity 5°C, 10% relative humidity 55°C, 16% relative humidity	600,000 software-controlled power on/off cycles 20,000 hard power on/off cycles					

**Table 2: Drive specifications**

Drive specification	ST9500327AS	ST9320327AS	ST9250317AS	ST9160317AS	ST9120317AS	ST980314AS
Warranty	For information regarding Warranty Support, visit <a href="http://www.seagate.com/www/en-us/support/warranty_&amp;_returns_assistance">http://www.seagate.com/www/en-us/support/warranty_&amp;_returns_assistance</a>					
Supports Hotplug operation per Serial ATA Revision 2.5 specification	Yes (requires COMRESET from host after a hotplug event)					

\*One Gbyte equals one billion bytes when referring to hard drive capacity. Accessible capacity may vary depending on operating environment and formatting.

\*\*During periods of drive idle, some offline activity may occur according to the S.M.A.R.T. specification, which may increase acoustic and power to operational levels.

\*\*\*Typical notebooks will pull power to the drive when entering S3 and S4; while in the S3 and S4 states, drive sleep and drive standby modes will not contribute to battery power consumption.

## 2.2 Formatted capacity

Model	Formatted capacity*	Guaranteed sectors	Bytes per sector
ST9500327AS	500 Gbytes	976,773,168	512
ST9320327AS	320 Gbytes	625,142,448	512
ST9250317AS	250 Gbytes	488,397,168	512
ST9160317AS	160 Gbytes	312,581,808	512
ST9120317AS	120 Gbytes	234,441,648	512
ST980314AS	80 Gbytes	156,301,488	512

\*One Gbyte equals one billion bytes when referring to hard drive capacity. Accessible capacity may vary depending on operating environment and formatting.

### 2.2.1 LBA mode

When addressing these drives in LBA mode, all blocks (sectors) are consecutively numbered from 0 to  $n-1$ , where  $n$  is the number of guaranteed sectors as defined above.

See Section 4.2.5, "Identify Device command" (words 60-61 and 100-103) for additional information about 48-bit addressing support of drives with capacities over 137 Gbytes.

## 2.3 Default logical geometry

Cylinders	Read/write heads	Sectors per track
16,383	16	63

### LBA mode

When addressing these drives in LBA mode, all blocks (sectors) are consecutively numbered from 0 to  $n-1$ , where  $n$  is the number of guaranteed sectors as defined above.

## 2.4 Physical organization

Drive model	Read/write heads	Number of disks
ST9500327AS	4	2
ST9320327AS	3	2
ST9250317AS	2	1
ST9160317AS	2	1
ST9120317AS	1	1
ST980314AS	1	1

## 2.5 Recording and interface technology

Interface	Serial ATA (SATA)
Recording method	Perpendicular
Recording density BPI (bits/inch max)	1490k
Track density TPI (tracks/inch max)	265k
Areal density (Gbits/inch <sup>2</sup> max)	394
Spindle speed (RPM) ( $\pm 0.2\%$ )	5400
Maximum Internal transfer rate (Mbits/sec)	1175
I/O data-transfer rate (Mbytes/sec max)	300
Interleave	1:1
Cache buffer	8 Mbytes (8192 kbytes)

## 2.6 Physical characteristics

Drive specification		
Height	(mm) (inches)	9.5 +/-0.2 0.374 +/-0.0079
Width	(mm) (inches)	69.85 +/-0.25 2.75 +/-0.0098
Length	(mm) (inches)	100.35 +0.20 / -0.25 3.957 +0.0079 / -0.0098
Typical weight	ST9500327AS ST9320327AS  ST9250317AS ST9160317AS ST9120317AS ST980314AS	98.8 grams 0.218 pounds  93.5 grams 0.206 pounds

## 2.7 Seek time

Seek measurements are taken with nominal power at 25°C ambient temperature. All times are measured using drive diagnostics. The specifications in the table below are defined as follows:

- Track-to-track seek time is an average of all possible single-track seeks in both directions.
- Average seek time is a true statistical random average of at least 5000 measurements of seeks between random tracks, less overhead.

Typical seek times (msec)	Read
Track-to-track (typical)	1
Average (typical)	14
Full-stroke (max)	30
Average latency	5.56

**Note.** These drives are designed to consistently meet the seek times represented in this manual. Physical seeks, regardless of mode (such as track-to-track and average), are expected to meet the noted values. However, due to the manner in which these drives are formatted, benchmark tests that include command overhead or measure logical seeks may produce results that vary from these specifications.

## 2.8 Start/stop times

Time to ready	Typical	Max @ 25°C
Power-on to Ready (sec)	3.6	3.8
Standby to Ready (sec)	1.8	2

## 2.9 Power specifications

The drive receives DC power (+5V) through a native SATA power connector.

### 2.9.1 Power consumption

Power requirements for the drives are listed in table 3. Typical power measurements are based on an average of drives tested, under nominal conditions, at 25°C ambient temperature.

- **Spinup power**

Spinup power is measured from the time of power-on to the time that the drive spindle reaches operating speed.

- **Seek mode**

During seek mode, the read/write actuator arm moves toward a specific position on the disk surface and does not execute a read or write operation. Servo electronics are active. Seek mode power is measured based on three random seek operations every 100 msec. This mode is not typical.

- **Read/write power and current**

Read/write power is measured with the heads on track, based on three 63 sector read or write operations every 100 msec.

- **Idle mode power**

Idle mode power is measured with the drive up to speed, with servo electronics active and with the heads in a random track location.

- **Standby mode**

During Standby mode, the drive accepts commands, but the drive is not spinning, and the servo and read/write electronics are in power-down model

**Table 3: DC power**

Power dissipation	+5V input average (25° C)
Spinup (max)	1.0 amps
Seek	1.54 watts
Read	1.40 watts
Write	1.78 watts
Idle, performance*	1.40 watts
Idle, active*	0.78 watts
Idle, low power mode*	0.67 watts
Standby**	0.22 watts
Sleep	0.22 watts

\*During periods of drive idle, some offline activity may occur according to the S.M.A.R.T. specification, which may increase acoustic and power to operational levels.

\*\*Standby power is measured at steady state (after 200ms from transition)

### 2.9.1.1 Typical current profile

29-Aug-08  
18:29:11

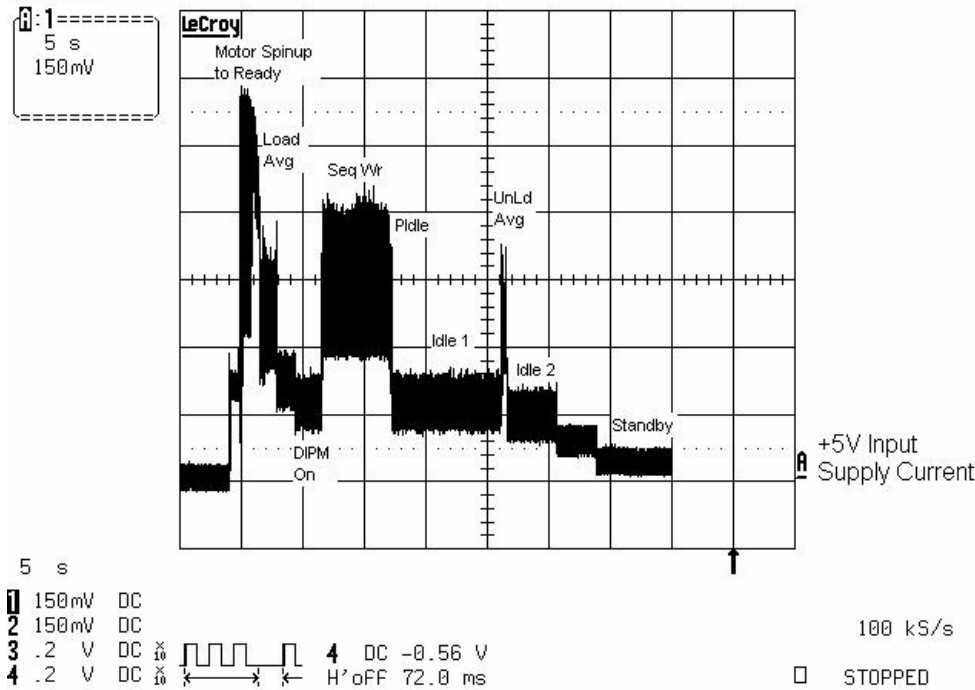

Figure 1. Typical +5V only startup and operation current profile

### 2.9.2 Deferred spinup

Momentum 5400 FDE.4 SATA drives do not support the deferred spinup option. If you require this option, refer to the Momentum 5400.3 SATA Blade Server family of drives.

### 2.9.3 Conducted noise

Input noise ripple is measured at the host system power supply across an equivalent 15-ohm resistive load on the +5 volt line.

Using 5-volt power, the drive is expected to operate with a maximum of 100 mV peak-to-peak square-wave injected noise at up to 10 MHz.

**Note.** Equivalent resistance is calculated by dividing the nominal voltage by the typical RMS read/write current.

### 2.9.4 Voltage tolerance

Voltage tolerance (including noise):

5V  $\pm$  5%



## 2.9.5 Power-management modes

The drive provides programmable power management to provide greater energy efficiency. In most systems, you can control power management through the system setup program. The drive features the following power-management modes:

**Table 4: Power management modes**

Power modes	Heads	Spindle	Buffer
Active (operating)	Tracking	Rotating	Full power
Idle, performance	Tracking	Rotating	Self refresh—low power
Idle, active	Floating	Rotating	Self refresh—low power
Idle, low power	Parked	Rotating	Self refresh—low power
Standby	Parked	Stopped	Self refresh—low power
Sleep	Parked	Stopped	Self refresh—low power

- **Active mode**

The drive is in Active mode during the read/write and seek operations.

- **Idle mode**

The buffer remains enabled, and the drive accepts all commands and returns to Active mode any time disk access is necessary.

- **Standby mode**

The drive enters Standby mode when the host sends a Standby Immediate command. If the host has set the standby timer, the drive can also enter Standby mode automatically after the drive has been inactive for a specifiable length of time. The standby timer delay is established using a Standby or Idle command. In Standby mode, the drive buffer is in Self Refresh Low Power mode, the heads are parked and the spindle is at rest. The drive accepts all commands and returns to Active mode any time disk access is necessary.

- **Sleep mode**

The drive enters Sleep mode after receiving a Sleep command from the host. In Sleep mode, the drive buffer is in Self Refresh Low Power mode, the heads are parked and the spindle is at rest. The drive leaves Sleep mode after it receives a Hard Reset or Soft Reset from the host. After receiving a reset, the drive exits Sleep mode and enters Standby mode with all current translation parameters intact.

- **Idle and Standby timers**

Each time the drive performs an Active function (read, write or seek), the standby timer is reinitialized and begins counting down from its specified delay times to zero. If the standby timer reaches zero before any drive activity is required, the drive makes a transition to Standby mode. In both Idle and Standby mode, the drive accepts all commands and returns to Active mode when disk access is necessary.

## 2.10 Environmental specifications

### 2.10.1 Ambient temperature

Ambient temperature is defined as the temperature of the environment immediately surrounding the drive. Actual drive case temperature should not exceed 65°C (149°F) within the operating ambient conditions.

Above 1,000 feet (305 meters), the maximum temperature is derated linearly by 1°C every 1000 feet.

Operating	0° to 60°C (32° to 140°F)
Nonoperating	−40° to 70°C (−40° to 158°F)

### 2.10.2 Temperature gradient

Operating	20°C per hour (68°F per hour max), without condensation
Nonoperating	35°C per hour (95°F per hour max), without condensation

### 2.10.3 Humidity

#### 2.10.3.1 Relative humidity

Operating	5% to 95% noncondensing (30% per hour max)
Nonoperating	5% to 95% noncondensing (30% per hour max)

#### 2.10.3.2 Wet bulb temperature

Operating	37.7°C (99.86°F max)
Nonoperating	40°C (104°F max)

### 2.10.4 Altitude

Operating	−304.8 m to 3048 m (−1000 ft to 10,000+ ft)
Nonoperating	−304.8 m to 12,192 m (−1000 ft to 40,000+ ft)

## 2.10.5 Shock

All shock specifications assume that the drive is mounted securely with the input shock applied at the drive mounting screws. Shock may be applied in the X, Y or Z axis.

### 2.10.5.1 Operating shock

These drives comply with the performance levels specified in this document when subjected to a maximum operating shock of 350 Gs based on half-sine shock pulses of 2 msec. Shocks should not be repeated more than two times per second.

### 2.10.5.2 Nonoperating shock

The nonoperating shock level that the drive can experience without incurring physical damage or degradation in performance when subsequently put into operation is 800 Gs based on a nonrepetitive half-sine shock pulse of 2 msec duration.

The nonoperating shock level that the drive can experience without incurring physical damage or degradation in performance when subsequently put into operation is 1000 Gs based on a nonrepetitive half-sine shock pulse of 1 msec duration.

The nonoperating shock level that the drive can experience without incurring physical damage or degradation in performance when subsequently put into operation is 600 Gs based on a nonrepetitive half-sine shock pulse of 0.5 msec duration.

## 2.10.6 Vibration

All vibration specifications assume that the drive is mounted securely with the input vibration applied at the drive mounting screws. Vibration may be applied in the X, Y or Z axis.

### 2.10.6.1 Operating vibration

The maximum vibration levels that the drive may experience while meeting the performance standards specified in this document are specified below.

---

5–500 Hz	1.0 Gs (0 to peak). Max displacement may apply below 10 Hz.
----------	---

---

### 2.10.6.2 Nonoperating vibration

The maximum nonoperating vibration levels that the drive may experience without incurring physical damage or degradation in performance when subsequently put into operation are specified below.

---

5–500 Hz	5.0 Gs (0 to peak). Max displacement may apply below 22 Hz.
----------	---

---

## 2.11 Acoustics

Drive emission of sound is measured consistent with the ECMA-74 and its' referenced standards. Testing is conducted at room temperature (approximately 25°C). Emission levels are reported as the total A-weighted sound power levels for steady state, idle, and active seek modes of operation.

Idle*	Performance seek
2.4 bels (typ) 2.6 bels (max)	2.6 bels (typ) 2.7 bels (max)

\*During periods of drive idle, some offline activity may occur according to the S.M.A.R.T. specification, which may increase acoustic and power to operational levels.

### Test for Prominent Discrete Tones (PDTs)

Seagate follows the ECMA-74 standards for measurement and identification of PDTs. An exception to this process is the use of the absolute threshold of hearing. Seagate uses the lower limit for the threshold curve\* to discern tone audibility and to compensate for the inaudible components of sound prior to computation of tone ratios according to Annex D of the ECMA-74 standards.

\*Defined as the median curve given by ISO 389-7 (Tf curve) minus 10dB at all frequencies.

## 2.12 Electromagnetic immunity

When properly installed in a representative host system, the drive operates without errors or degradation in performance when subjected to the radio frequency (RF) environments defined in the following table:

Test	Description	Performance level	Reference standard
Electrostatic discharge	Contact, HCP, VCP: $\pm 4$ kV; Air: $\pm 8$ kV	B	EN 61000-4-2: 95
Radiated RF immunity	80 to 2,000 MHz, 10 V/m, 80% AM with 1 kHz sine 900 MHz, 3 V/m, 50% pulse modulation @ 200 Hz	A	EN 61000-4-3: 96 ENV 50204: 95
Electrical fast transient	$\pm 1$ kV on AC mains, $\pm 0.5$ kV on external I/O	B	EN 61000-4-4: 95
Surge immunity	$\pm 1$ kV differential, $\pm 2$ kV common, AC mains	B	EN 61000-4-5: 95
Conducted RF immunity	150 kHz to 80 MHz, 3 Vrms, 80% AM with 1 kHz sine	A	EN 61000-4-6: 97
Power Frequency H-field immunity	1 A/m, 50Hz/60Hz, 3 axes	A	EN 61000-4-8: 97
Voltage dips, interrupts	30% Reduction for 25 cycles >95% Reduction for 250 cycles >95%, 0.5 cycles	C C B	EN 61000-4-11: 94

## 2.13 Reliability

Measurement type	Specification
Nonrecoverable read errors	1 per 10 <sup>14</sup> bits read, max.
Annualized Failure Rate (AFR)	<0.48%
Load/Unload (U/UL)  25°C, 50% relative humidity  32°C, 80% relative humidity 5°C, 80% relative humidity 5°C, 10% relative humidity 55°C, 16% relative humidity	600,000 software-controlled power on/off cycles 20,000 hard power on/off cycles  600,000 software-controlled power on/off cycles 20,000 hard power on/off cycles
Warranty	For information regarding Warranty Support, visit <a href="http://www.seagate.com/www/en-us/support/warranty_&amp;_returns_assistance">http://www.seagate.com/www/en-us/support/warranty_&amp;_returns_assistance</a>

## 2.14 Agency certification

### 2.14.1 Safety certification

The drives are recognized in accordance with UL 60950-1 and CSA C22.2 (60950) and meet all applicable sections of IEC950 and EN 60950 as tested by UL Singapore and TUV SUD PSB Singapore.

### 2.14.2 Electromagnetic compatibility

Hard drives that display the CE mark comply with the European Union (EU) requirements specified in the Electromagnetic Compatibility Directive (2004/108/EEC). Testing is performed to the levels specified by the product standards for Information Technology Equipment (ITE). Emission levels are defined by EN 55022, Class B and the immunity levels are defined by EN 55024.

Seagate uses an independent laboratory to confirm compliance with the EC directives specified in the previous paragraph. Drives are tested in representative end-user systems. Although CE-marked Seagate drives comply with the directives when used in the test systems, we cannot guarantee that all systems will comply with the directives. The drive is designed for operation inside a properly designed enclosure, with properly shielded I/O cable (if necessary) and terminators on all unused I/O ports. Computer manufacturers and system integrators should confirm EMC compliance and provide CE marking for their products.

## Korean RRL

If these drives have the Korea Communication Commission (KCC) logo, they comply with paragraph 1 of Article 11 of the Electromagnetic Compatibility control Regulation and meet the Electromagnetic Compatibility (EMC) Framework requirements of the Radio Research Laboratory (RRL) Ministry of Information and Communication Republic of Korea.

These drives have been tested and comply with the Electromagnetic Interference/Electromagnetic Susceptibility (EMI/EMS) for Class B products. Drives are tested in a representative, end-user system by a Korean-recognized lab.

- Certificate number: STX-54006 (B)
- Trade name or applicant: Seagate Technology LLC
- Manufacturing date: October 01, 2008 (Date of Certification)
- Manufacturer/nationality: USA, Singapore and China

## Australian C-Tick (N176)

If these models have the C-Tick marking, they comply with the Australia/New Zealand Standard AS/NZS CISPR22 2006 and meet the Electromagnetic Compatibility (EMC) Framework requirements of the Australian Communication Authority (ACA).

### 2.14.3 FCC verification

These drives are intended to be contained solely within a personal computer or similar enclosure (not attached as an external device). As such, each drive is considered to be a subassembly even when it is individually marketed to the customer. As a subassembly, no Federal Communications Commission verification or certification of the device is required.

Seagate Technology International has tested this device in enclosures as described above to ensure that the total assembly (enclosure, disk drive, motherboard, power supply, etc.) does comply with the limits for a Class B computing device, pursuant to Subpart J, Part 15 of the FCC rules. Operation with noncertified assemblies is likely to result in interference to radio and television reception.

**Radio and television interference.** This equipment generates and uses radio frequency energy and if not installed and used in strict accordance with the manufacturer's instructions, may cause interference to radio and television reception.

This equipment is designed to provide reasonable protection against such interference in a residential installation. However, there is no guarantee that interference will not occur in a particular installation. If this equipment does cause interference to radio or television, which can be determined by turning the equipment on and off, you are encouraged to try one or more of the following corrective measures:

- Reorient the receiving antenna.
- Move the device to one side or the other of the radio or TV.
- Move the device farther away from the radio or TV.
- Plug the computer into a different outlet so that the receiver and computer are on different branch outlets.

If necessary, you should consult your dealer or an experienced radio/television technician for additional suggestions. You may find helpful the following booklet prepared by the Federal Communications Commission: *How to Identify and Resolve Radio-Television Interference Problems*. This booklet is available from the Superintendent of Documents, U.S. Government Printing Office, Washington, DC 20402. Refer to publication number 004-000-00345-4.

## 2.15 Environmental protection

Seagate designs its products to meet environmental protection requirements worldwide, including regulations restricting certain chemical substances.

### 2.15.1 European Union Restriction of Hazardous Substances (RoHS)

Seagate designs its products to meet environmental protection requirements worldwide, including regulations restricting certain chemical substances. A new law, the European Union Restriction of Hazardous Substances (RoHS) Directive, restricts the presence of chemical substances, including Lead, Cadmium, Mercury, Hexavalent Chromium, PBB and PBDE, in electronic products, effective July 2006. This drive is manufactured with components and materials that comply with the RoHS Directive.

### 2.15.2 China Restriction of Hazardous Substances (RoHS) Directive

中国限制危险物品的指令

This product has an Environmental Protection Use Period (EPUP) of 20 years. The following table contains information mandated by China's "Marking Requirements for Control of Pollution Caused by Electronic Information Products" Standard.



该产品具有20年的环境保护使用周期（EPUP）。下表包含了中国“电子产品所导致的污染的控制的记号要求”所指定的信息。

Name of Parts 部件名称	Toxic or Hazardous Substances or Elements有毒有害物质或元素					
	Lead 铅 (Pb)	Mercury 汞 (Hg)	Cadmium 镉 (Cd)	Hexavalent Chromium 六价铬 (Cr6+)	Polybrominated Biphenyl 多溴联苯 (PBB)	Polybrominated Diphenyl Ether 多溴二苯醚 (PBDE)
PCBA	X	O	O	O	O	O
HDA	X	O	O	O	O	O

"O" indicates the hazardous and toxic substance content of the part (at the homogenous material level) is lower than the threshold defined by the China RoHS MCV Standard.

“O”表示该部件（于同类物品程度上）所含的危险和有毒物质低于中国RoHS MCV标准所定义的阈值。

"X" indicates the hazardous and toxic substance content of the part (at the homogenous material level) is over the threshold defined by the China RoHS MCV Standard.

“X”表示该部件（于同类物品程度上）所含的危险和有毒物质超出中国RoHS MCV标准所定义的阈值。

## 2.16 Corrosive environment

Seagate electronic drive components pass accelerated corrosion testing equivalent to 10 years exposure to light industrial environments containing sulfurous gases, chlorine and nitric oxide, classes G and H per ASTM B845. However, this accelerated testing cannot duplicate every potential application environment.

Users should use caution exposing any electronic components to uncontrolled chemical pollutants and corrosive chemicals as electronic drive component reliability can be affected by the installation environment. The silver, copper, nickel and gold films used in Seagate products are especially sensitive to the presence of sulfide, chloride, and nitrate contaminants. Sulfur is found to be the most damaging. In addition, electronic components should never be exposed to condensing water on the surface of the printed circuit board assembly (PCBA) or exposed to an ambient relative humidity greater than 95%. Materials used in cabinet fabrication, such as vulcanized rubber, that can outgas corrosive compounds should be minimized or eliminated. The useful life of any electronic equipment may be extended by replacing materials near circuitry with sulfide-free alternatives.

## 3.0 Configuring and mounting the drive

---

This section contains the specifications and instructions for configuring and mounting the drive.

Momentum 5400 FDE.4 SATA drives may be connected to any computer system that supports a standard SATA interface.

You can elect to use Momentum 5400 FDE.4 SATA drives in one of two different security modes:

1. ATA Security mode (available on all models documented in this manual)  
To operate in ATA Security mode, you only need a host system and operating system that supports the existing ATA Security Command Set. The drive is shipped to operating in this mode, ready to use.
2. DriveTrust Security mode  
To enable a robust enterprise-level security and management policy, you may elect to operate in DriveTrust Security mode. To do so, you will need to use a third-party security application to manage the DriveTrust features. Please contact your system or software provider for more details.

Refer to Table 1 on page 2 to determine which mode is best for your particular solution.

**Note.** As with any disk drive, Seagate highly encourages consumers to consistently back up their data as well as the security pre-boot password, user name, and domain name on another storage device. Seagate is not responsible for lost or stolen authentication data such as passwords, user names, domain names, or any authentication data perceived to be inoperative, and as a consequence of lost or stolen passwords, user names, or domain names, Seagate cannot be held liable for data that cannot be retrieved from the drive due to inability to authenticate the user to the drive as required by the security pre-boot software.

### 3.1 Handling and static-discharge precautions

After unpacking, and before installation, the drive may be exposed to potential handling and electrostatic discharge (ESD) hazards. Observe the following standard handling and static-discharge precautions:

**Caution:**

- Keep the drive in the electrostatic discharge (ESD) bag until you are ready for installation to limit the drive's exposure to ESD.
- Before handling the drive, put on a grounded wrist strap, or ground yourself frequently by touching the metal chassis of a computer that is plugged into a grounded outlet. Wear a grounded wrist strap throughout the entire installation procedure.
- Handle the drive only by its edges or frame.
- The drive is fragile—handle it with care. Do not press down on the drive top cover.
- Always rest the drive on a padded, antistatic surface until you mount it in the computer.
- Do not touch the connector pins or the printed circuit board.
- Do not remove the factory-installed labels from the drive or cover them with additional labels. Removal voids the warranty. Some factory-installed labels contain information needed to service the drive. Other labels are used to seal out dirt and contamination.



### 3.2 Configuring the drive

Each drive on the Serial ATA interface connects in a point-to-point configuration with the Serial ATA host adapter. There is no master/slave relationship because each drive is considered a master in a point-to-point relationships. If two drives are attached on one Serial ATA host adapter, the host operating system views the two devices as if they were both “masters” on two separate ports. This means both drives behave as if they are Device 0 (master) devices.

Serial ATA drives are designed for easy installation. It is normally not necessary to set any jumpers on this drive for proper operation. If the host system does not support SATA 3Gb/s operation, place a jumper on pins 1 and 2 to limit the drive to 1.5Gb/s operation.

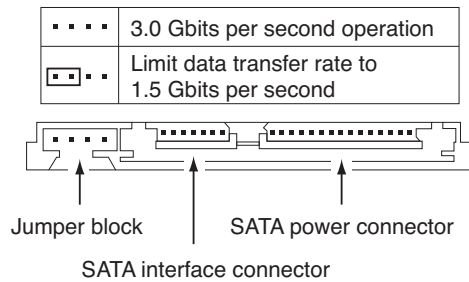

Figure 2. Serial ATA connectors

### 3.3 Serial ATA cables and connectors

The Serial ATA interface cable consists of four conductors in two differential pairs, plus three ground connections. The cable size may be 30 to 26 AWG with a maximum length of one meter (39.37 inches). See Table 5 for connector pin definitions. Either end of the SATA signal cable can be attached to the drive or host.

For direct backplane connection, the drive connectors are inserted directly into the host receptacle. The drive and the host receptacle incorporate features that enable the direct connection to be hot pluggable and blind mateable.

For installations which require cables, you can connect the drive as illustrated in Figure 3.

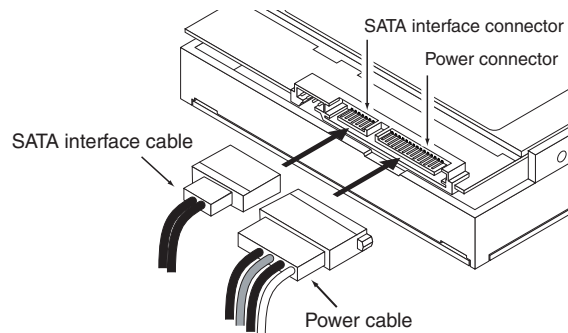

Figure 3. Attaching SATA cabling

Each cable is keyed to ensure correct orientation.

### 3.4 Drive mounting

You can mount the drive using four screws in the side-mounting holes or four screws in the bottom-mounting holes. See Figure 4 for drive mounting dimensions. Follow these important mounting precautions when mounting the drive:

- Allow a minimum clearance of 0.030 inches (0.76 mm) around the entire perimeter of the drive for cooling.
- Use only M3 UNC mounting screws.
- Do not overtighten the mounting screws. Maximum torque: 4.0 inch-lb (0.4519 N-m).
- Four (4) threads (0.080 inches, 2.032 mm) minimum screw engagement recommended.
- Avoid excessive drive distortion when mounting. Refer to the following specifications for stiffness/deflection information:

<b>Top cover stiffness/deflection</b>	
Operating with no performance degradation, emitted noise, mechanical damage, or hard errors	10 mm probe: 1.02kgf or 5 mm probe: 0.92kgf
Non-operating with no hard errors	20 mm probe: 2kgf at any point of top cover 20 mm probe: 15kgf at top cover edges only

Measurements shown in Figure 4 are in inches.

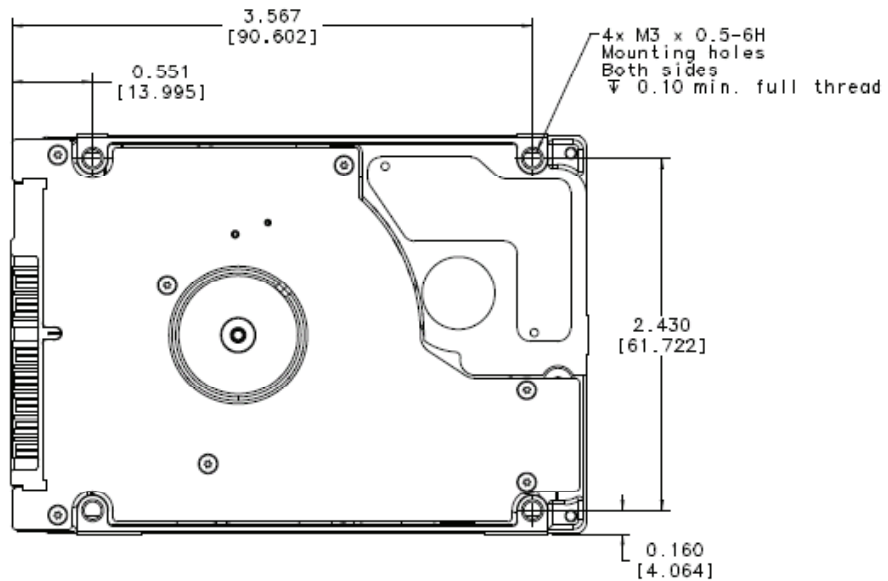
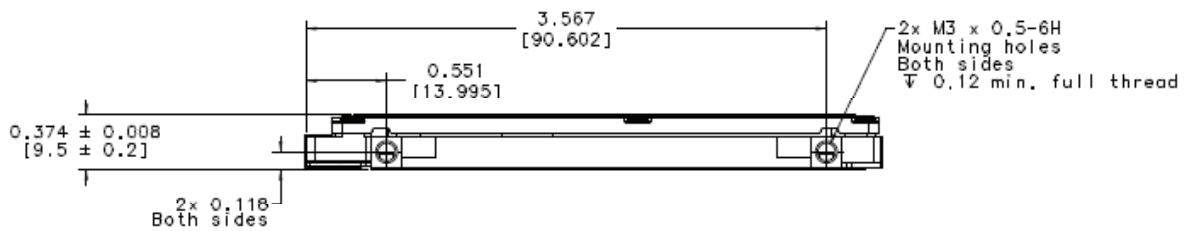
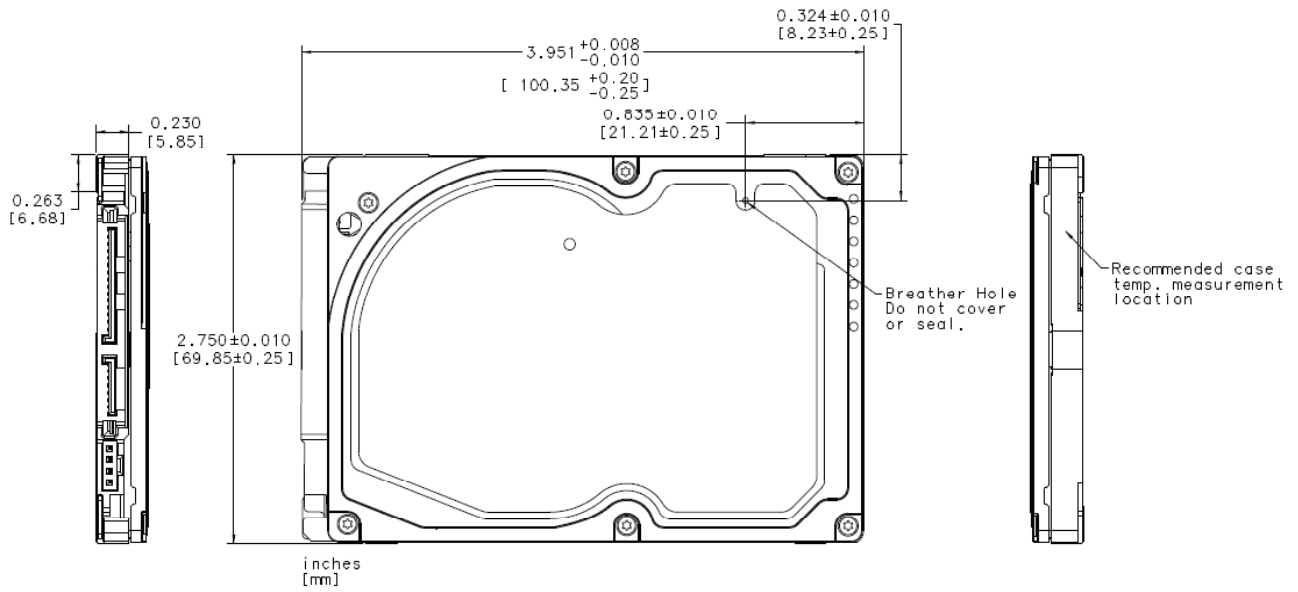

Figure 4. Mounting dimensions

### 3.5 Drive integration

Momentus 5400 FDE.4 SATA drives may be installed in the target computer system in exactly the same way as a non-FDE Momentus drive.



Figure 5. Momentus 5400 FDE.4 SATA drive label example

To install the drive in the system:

1. Remove the drive from the packaging material.
2. Install the drive in the computer system.
3. Load any desired images and operating system to the drive.
4. Install other components and options.
5. Set the original Master Password to a new value (see Section 1.2.1 for information about setting the SID) utilizing System/BIOS or third party software (optional).

No password is required to change the Master password when the drive is in the unlocked state.

The drive remains in the unlocked state until a User password is set.

After the installation procedure is complete, the computer is ready to be shipped to the customer.

**Note.** The manufacturer of the computer system (system integrator) does not have to enter any password. The installation procedure for the Momentus 5400 FDE.4 SATA is exactly the same as the Momentus 5400.5 SATA.

### 3.5.1 Drive installation

Upon receipt by the consumer, the drive's user interface is identical to a Momentus 5400.5 drive. The normal ATA security commands are functioning and available for initialization of the password as follows:

Per normal ATA Security Commands specifications, the drive is unlocked and all ATA security commands and all normal ATA commands may be issued.

1. Consumer accesses the computer manufacturer's BIOS set-up screen.
2. Consumer selects option to set User Password.  
After setting the User password, the drive is now under access control (locked) and will require a password for future accesses.
3. Optional: Consumer selects the option to set the Master password from the BIOS choices.
4. Consumer exits the BIOS settings menu and continues with the boot process.
5. The BIOS enters the Security Freeze Command (F5) prior to exiting the boot sequence.

### 3.5.2 Consumer usage

After initialization, the consumer will just need to enter their User password each time the computer is booted according to the following description:

1. The computer system is turned on or the hardware is reset.
2. The drive reports to the BIOS that it is in the locked state per standard ATA Security Command reporting.
3. The BIOS queries the user for the password.
4. The BIOS supplies the password to the drive using the Security Unlock Command (F2).
5. The drive is unlocked and the BIOS may continue the booting process.
6. The BIOS enters the Security Freeze Lock Command (F5) prior to exiting the boot sequence.

**Note.** To ensure that the system reauthenticates the user, turn the laptop power off (shut down) rather than putting it in sleep mode. The system will authenticate the user at powerup.

## 3.6 Security Erase--ATA security commands

The Momentus 5400 FDE.4 SATA provides powerful features for cryptographically erasing the drive for disposal or repurposing. The drive uses the ATA Security Erase Prepare (F3) and ATA Security Erase (F4) commands to perform the cryptographic erase.

### 3.6.1 Secure Erase procedure

Using the Security Erase commands, the drive's cryptographic key can be replaced according to the following procedure:

1. Consumer boots up the computer normally according to the Consumer Usage section above.
2. Consumer invokes software or BIOS option for Erase.
3. The software or BIOS queries the user for either the User or Master password.
4. The software or BIOS issues the Security Erase Prepare (F3) command.
5. The software or BIOS issues the Security Erase Unit (F4) command.  
Select the Enhanced erase for cryptographic key erasure that completes in less than one second.

### 3.6.2 Drive State after Secure Erase

Upon completion of the erase sequence, the existing cryptographic key is erased, rendering all existing data unintelligible, and the drive has been returned to the manufactured state as follows:

- The existing encryption key is deleted.
- A new random encryption key has been created on the drive.
- Encryption function is active and functioning.  
The new key is used to encrypt all user data on write and decrypt on read.
- The user interface to the drive is active and all read and write commands are allowed.
- The ATA User password is reset to null (no value).
- The ATA Master password is not modified  
The ATA Master password is the same value as it was before the erase.
- The ATA Security is set to the Unlocked state.  
No password is required to access the drive.

The drive may now be disposed of safely, or the drive may be returned to service for another consumer following the initialization procedure defined above. Drives returned to Seagate for warranty purposes have special requirements. See the warranty information in Section 2.13 for additional details.

## 4.0 Serial ATA interface

---

These drives use the industry-standard Serial ATA (SATA) interface that supports FIS data transfers. It supports ATA programmed input/output (PIO) modes 0–4; multiword DMA modes 0–2, and Ultra DMA modes 0–6. The drive also supports the use of the IORDY signal to provide reliable high-speed data transfers.

For detailed information about the Serial ATA interface, refer to the “Serial ATA: High Speed Serialized AT Attachment” specification.

### 4.1 Hot-Plug compatibility

Momentum 5400 FDE.4 SATA drives incorporate connectors which enable you to hot plug these drives in accordance with the Serial ATA: High Speed Serialized AT Attachment specification revision 2.0. This specification can be downloaded from <http://www.serialata.org>. This device requires a COMRESET from the host after a hotplug event.

### 4.2 Serial ATA device plug connector pin definitions

Table 5 summarizes the signals on the Serial ATA interface and power connectors..

**Table 5: Serial ATA connector pin definitions**

Segment	Pin	Function	Definition
	S1	Ground	2nd mate
	S2	A+	Differential signal pair A from Phy
	S3	A-	
	S4	Ground	2nd mate
	S5	B-	Differential signal pair B from Phy
	S6	B+	
<b>Signal</b>	S7	Ground	2nd mate

Key and spacing separate signal and power segments

---

**Table 5: Serial ATA connector pin definitions**

Segment	Pin	Function	Definition
Power	P1	V <sub>33</sub>	3.3V power
	P2	V <sub>33</sub>	3.3V power
	P3	V <sub>33</sub>	3.3V power, pre-charge, 2nd mate
	P4	Ground	1st mate
	P5	Ground	2nd mate
	P6	Ground	2nd mate
	P7	V <sub>5</sub>	5V power, pre-charge, 2nd mate
	P8	V <sub>5</sub>	5V power
	P9	V <sub>5</sub>	5V power
	P10	Ground	2nd mate
	P11	Reserved	The pin corresponding to P11 in the backplane receptacle connector is also reserved The corresponding pin to be mated with P11 in the power cable receptacle connector shall always be grounded
	P12	Ground	1st mate.
	P13	V <sub>12</sub>	12V power, pre-charge, 2nd mate
	P14	V <sub>12</sub>	12V power
	P15	V <sub>12</sub>	12V power

**Notes:**

- All pins are in a single row, with a 1.27 mm (0.050") pitch.
- The comments on the mating sequence apply to the case of backplane blindmate connector only. In this case, the mating sequences are:
  - the ground pins P4 and P12.
  - the pre-charge power pins and the other ground pins.
  - the signal pins and the rest of the power pins.
- There are three power pins for each voltage. One pin from each voltage is used for pre-charge when installed in a blind-mate backplane configuration.
- All used voltage pins (V<sub>x</sub>) must be terminated.

**4.2.1 ATA Security policy exceptions**

In the ATA Security Interface mode, the drive conforms to the ATA Security Policy, except the following desirable exceptions to implement the desired Momentus 5400 FDE.4 SATA behavior:

Upon execution of the secure erase sequence, the drive will have the following behavior:

- All secure erase modes will instantaneously delete the encryption key rendering all user data unintelligible.
- A new encryption key will be generated inside the drive replacing the previous encryption key.
- The new encryption/decryption key will be applied to the data for all subsequent writes/reads prior to the next secure erase sequence.
- The user password will be cleared to a null value.
- The master password will retain the current value per the ATA specification.

**Note.** On completion of this sequence, the user is assured that all sectors on the drive are unintelligible and



the drive is returned to the default factory state. It is then immediately ready for disposal or repurposing.

The ATA Security Erase Unit Command provides for normal and enhanced erase modes as follows:

**Table 6: ATA Security Erase Unit bits**

Word	Content		
0	Control word		
	Bit 0	Identifier	0 = Compare User password
			1 = Compare Master password
	Bit 1	Erase mode	0 = Normal Erase
			1 = Enhanced Erase
	Bit (15:2)	Reserved	
1 - 16	Password (32 bytes)		
17 - 255	Reserved		

Choosing enhanced erase mode will simply perform the cryptographic erase described above, and return status almost immediately. This is the recommended option.

To maintain consistency with the ATA Security specification, Momentus 5400 FDE.4 SATA drives provide an option to perform the Normal Erase mode.

Choosing normal erase will result in the drive performing the cryptographic erase which is the same as choosing enhanced erase.

#### 4.2.2 DriveTrust Mode support

Identify Page - Word 150 decimal (0x96h)- Bit 12 Identifies DriveTrust Support.

Value = 1 = DriveTrust is supported

**Table 7: DriveTrust Identify Page**

Ident Value	BIT set	Bit	Description
5	0	15	Vendor specific
	1	14	Vendor specific
	0	13	Vendor specific
	1	12	DriveTrust Enabled
0	0	11	Vendor specific
	0	10	Vendor specific
	0	9	Vendor specific
	0	8	Vendor specific
9	1	7	Vendor specific
	0	6	Vendor specific
	0	5	Vendor specific
	1	4	DriveTrust Supported
8	1	3	Vendor specific
	0	2	Vendor specific
	0	1	Vendor specific
	0	0	Vendor specific

### 4.2.3 Full Disk Encryption support

Identify Page--Word 243 decimal (0xF3h)--bit 14 indicates Full Disk Encryption capability.

1 = Full Disk Encryption supported.

**Table 8: Full Disk Encryption Identify Page**

Ident Value	BIT set	Bit	Description
4	0	15	Vendor specific
	1	14	Full Disk Encryption
	0	13	Vendor specific
	0	12	Vendor specific
0	0	11	Vendor specific
	0	10	Vendor specific
	0	9	Vendor specific
	0	8	Vendor specific
0	0	7	Vendor specific
	0	6	Vendor specific
	0	5	Vendor specific
	0	4	Vendor specific
0	0	3	Vendor specific
	0	2	Vendor specific
	0	1	Vendor specific
	0	0	Vendor specific

#### 4.2.4 Supported ATA commands

The following table lists ATA-standard commands that the drive supports. For a detailed description of the ATA commands, refer to the Serial ATA: High Speed Serialized AT Attachment specification. See “S.M.A.R.T. commands” on page 38 for details and subcommands used in the S.M.A.R.T. implementation.

**Table 9: Supported commands**

Op Code	Command	ATA Security API			DriveTrust Security API	
		Locked	Unlocked	Frozen	Secure State	Authenticated State
<b>Special Commands</b>						
5C	TRUSTED RECEIVE (PIO)	Executable	Executable	Executable	Executable	Executable
5D	TRUSTED RECEIVE DMA	Executable	Executable	Executable	Executable	Executable
5E	TRUSTED SEND (PIO)	Executable	Executable	Executable	Executable	Executable
5F	TRUSTED SEND DMA	Executable	Executable	Executable	Executable	Executable
<b>Normal Commands</b>						
E5	CHECK POWER MODE	Executable	Executable	Executable	Executable	Executable
98	CHECK POWER MODE	Executable	Executable	Executable	Executable	Executable
51	CONFIGURE STREAM	Aborted	Executable	Executable	Aborted	Executable
B1	DEVICE CONFIGURATION	Aborted	Executable	Executable	Aborted	Executable
08	DEVICE RESET	Executable	Executable	Executable	Executable	Executable
92	DOWNLOAD MICROCODE	Aborted	Aborted	Aborted	Aborted	Aborted
90	EXECUTE DEVICE DIAGNOSTIC	Executable	Executable	Executable	Executable	Executable
E7	FLUSH CACHE	Aborted	Executable	Executable	Aborted	Executable
EA	FLUSH CACHE EXT	Aborted	Executable	Executable	Aborted	Executable
EC	IDENTIFY DEVICE	Executable	Executable	Executable	Executable	Executable
A1	IDENTIFY PACKET DEVICE	Executable	Executable	Executable	Executable	Executable
E3	IDLE	Executable	Executable	Executable	Executable	Executable
97	IDLE	Executable	Executable	Executable	Executable	Executable
E1	IDLE IMMEDIATE	Executable	Executable	Executable	Executable	Executable
95	IDLE IMMEDIATE	Executable	Executable	Executable	Executable	Executable
00	NOP	Executable	Executable	Executable	Executable	Executable
E4	READ BUFFER	Aborted	Executable	Executable	Aborted	Executable
C8	READ DMA	Aborted	Executable	Executable	Aborted	Executable
C9	READ DMA	Aborted	Executable	Executable	Aborted	Executable
25	READ DMA EXT	Aborted	Executable	Executable	Aborted	Executable

**Table 9: Supported commands**

Op Code	Command	ATA Security API			DriveTrust Security API	
		Locked	Unlocked	Frozen	Secure State	Authenticated State
2F	READ LOG EXT	Executable	Executable	Executable	Executable	Executable
C4	READ MULTIPLE	Aborted	Executable	Executable	Aborted	Executable
29	READ MULTIPLE EXT	Aborted	Executable	Executable	Aborted	Executable
F8	READ NATIVE MAX ADDRESS	Executable	Executable	Executable	Executable	Executable
27	READ NATIVE MAX ADDRESS EXT	Executable	Executable	Executable	Executable	Executable
20	READ SECTOR(S)	Aborted	Executable	Executable	Aborted	Executable
21	READ SECTOR(S)	Aborted	Executable	Executable	Aborted	Executable
24	READ SECTOR(S) EXT	Aborted	Executable	Executable	Aborted	Executable
2A	READ STREAM DMA EXT	Aborted	Executable	Executable	Aborted	Executable
2B	READ STREAM EXT	Aborted	Executable	Executable	Aborted	Executable
40	READ VERIFY SECTOR(S)	Aborted	Executable	Executable	Aborted	Executable
41	READ VERIFY SECTOR(S)	Aborted	Executable	Executable	Aborted	Executable
42	READ VERIFY SECTOR(S) EXT	Aborted	Executable	Executable	Aborted	Executable
10	RECALIBRATE	Executable	Executable	Executable	Executable	Executable
F6	SECURITY DISABLE PASSWORD	Aborted	Executable	Aborted	Aborted	Aborted
F3	SECURITY ERASE PREPARE	Executable	Executable	Aborted	Aborted	Aborted
F4	SECURITY ERASE UNIT	Executable	Executable	Aborted	Aborted	Aborted
F5	SECURITY FREEZE LOCK	Aborted	Executable	Executable	Aborted	Executable
F1	SECURITY SET PASSWORD	Aborted	Executable	Aborted	Aborted	Aborted
F2	SECURITY UNLOCK	Executable	Executable	Aborted	Executable	Executable
70	SEEK	Executable	Executable	Executable	Executable	Executable
91	SET DRIVE PARAMETERS	Executable	Executable	Executable	Executable	Executable
EF	SET FEATURES	Executable	Executable	Executable	Executable	Executable
F9 <sub>H</sub>	SET MAX ADDRESS	Aborted	Executable	Executable	Aborted	Executable
F9 <sub>H</sub> / 00 <sub>H</sub>	SET MAX ADDRESS EXT	Aborted	Executable	Executable	Aborted	Executable
F9 <sub>H</sub> / 01 <sub>H</sub>	SET MAX SET PASSWORD	Aborted	Executable	Executable	Aborted	Executable
F9 <sub>H</sub> / 02 <sub>H</sub>	SET MAX LOCK	Aborted	Executable	Executable	Aborted	Executable

**Table 9: Supported commands**

Op Code	Command	ATA Security API			DriveTrust Security API	
		Locked	Unlocked	Frozen	Secure State	Authenticated State
F9 <sub>H</sub> / 04 <sub>H</sub>	SET MAX FREEZE LOCK	Aborted	Executable	Executable	Aborted	Executable
F9 <sub>H</sub> / 03 <sub>H</sub>	SET MAX UNLOCK	Aborted	Executable	Executable	Aborted	Executable
C6	SET MULTIPLE MODE	Executable	Executable	Executable	Executable	Executable
E6	SLEEP	Executable	Executable	Executable	Executable	Executable
99	SLEEP	Executable	Executable	Executable	Executable	Executable
B0 <sub>H</sub> / D9 <sub>H</sub>	SMART DISABLE OPERATIONS	Executable	Executable	Executable	Executable	Executable
B0 <sub>H</sub> / D2 <sub>H</sub>	SMART ENABLE/DISABLE AUTOSAVE	Executable	Executable	Executable	Executable	Executable
B0 <sub>H</sub> / D8 <sub>H</sub>	SMART ENABLE OPERATIONS	Executable	Executable	Executable	Executable	Executable
B0 <sub>H</sub> / D4 <sub>H</sub>	SMART EXECUTE OFF-LINE IMMEDIATE	Executable	Executable	Executable	Executable	Executable
B0 <sub>H</sub> / 08 <sub>H</sub>	SMART READ DATA	Executable	Executable	Executable	Executable	Executable
B0 <sub>H</sub> / D5 <sub>H</sub>	SMART READ LOG	Executable	Executable	Executable	Executable	Executable
B0 <sub>H</sub> / DA <sub>H</sub>	SMART RETURN STATUS	Executable	Executable	Executable	Executable	Executable
B0 <sub>H</sub> / D6 <sub>H</sub>	SMART WRITE LOG	Executable	Executable	Executable	Executable	Executable
E2	STANDBY	Executable	Executable	Executable	Executable	Executable
96	STANDBY	Executable	Executable	Executable	Executable	Executable
E0	STANDBY IMMEDIATE	Executable	Executable	Executable	Executable	Executable
94	STANDBY IMMEDIATE	Executable	Executable	Executable	Executable	Executable
E8	WRITE BUFFER	Aborted	Executable	Executable	Aborted	Executable
CA	WRITE DMA	Aborted	Executable	Executable	Aborted	Executable
CB	WRITE DMA	Aborted	Executable	Executable	Aborted	Executable
35	WRITE DMA EXT	Aborted	Executable	Executable	Aborted	Executable
3D	WRITE DMA FUA EXT	Aborted	Executable	Executable	Aborted	Executable
3F	WRITE LOG EXT	Aborted	Executable	Executable	Aborted	Executable
C5	WRITE MULTIPLE	Aborted	Executable	Executable	Aborted	Executable
39	WRITE MULTIPLE EXT	Aborted	Executable	Executable	Aborted	Executable
30	WRITE SECTOR(S)	Aborted	Executable	Executable	Aborted	Executable
31	WRITE SECTOR(S)	Aborted	Executable	Executable	Aborted	Executable
34	WRITE SECTOR(S) EXT	Aborted	Executable	Executable	Aborted	Executable

**Table 9: Supported commands**

Op Code	Command	ATA Security API			DriveTrust Security API	
		Locked	Unlocked	Frozen	Secure State	Authenticated State
3A	WRITE STREAM DMA EXT	Aborted	Executable	Executable	Aborted	Executable
3B	WRITE STREAM EXT	Aborted	Executable	Executable	Aborted	Executable

#### 4.2.5 Identify Device command

The Identify Device command (command code EC<sub>H</sub>) transfers information about the drive to the host following power up. The data is organized as a single 512-byte block of data, whose contents are shown in the table below. All reserved bits or words should be set to zero. Parameters listed with an “x” are drive-specific or vary with the state of the drive.

The following commands contain drive-specific features that may not be included in the Serial ATA specification.

Word	Description	Value
0	Configuration information: • Bit 15: 0 = ATA; 1 = ATAPI • Bit 7: removable media • Bit 6: removable controller • Bit 0: reserved	0C5A <sub>H</sub>
1	Number of logical cylinders	16,383
2	ATA-reserved	0000 <sub>H</sub>
3	Number of logical heads	16
4	Retired	0000 <sub>H</sub>
5	Retired	0000 <sub>H</sub>
6	Number of logical sectors per logical track: 63	003F <sub>H</sub>
7–9	Retired	0000 <sub>H</sub>
10–19	Serial number: (20 ASCII characters, 0000 <sub>H</sub> = none)	ASCII
20	Retired	0000 <sub>H</sub>
21	Retired	0400 <sub>H</sub>
22	Obsolete	0000 <sub>H</sub>
23–26	Firmware revision (8 ASCII character string, padded with blanks to end of string)	x.xx
27–46	Drive model number: (40 ASCII characters, padded with blanks to end of string)	ST9500327AS ST9320327AS ST9250317AS ST9160317AS ST9120317AS ST980314AS
47	(Bits 7–0) Maximum sectors per interrupt on Read multiple and Write multiple (16)	8001 <sub>H</sub>

Word	Description	Value
48	Reserved	0000 <sub>H</sub>
49	Standard Standby timer, IORDY supported and may be disabled	2F00 <sub>H</sub>
50	ATA-reserved	0000 <sub>H</sub>
51	PIO data-transfer cycle timing mode	0200 <sub>H</sub>
52	Retired	0200 <sub>H</sub>
53	Words 54–58, 64–70 and 88 are valid	0007 <sub>H</sub>
54	Number of current logical cylinders	xxxx <sub>H</sub>
55	Number of current logical heads	xxxx <sub>H</sub>
56	Number of current logical sectors per logical track	xxxx <sub>H</sub>
57–58	Current capacity in sectors	xxxx <sub>H</sub>
59	Number of sectors transferred during a Read Multiple or Write Multiple command	xxxx <sub>H</sub>
60–61	Total number of user-addressable LBA sectors. This field contains a value that is one greater than the total number of user-addressable sectors. The maximum value that shall be placed in this field is 0FFFFFFh. The 0FFFFFFh value applies to all capacities over 137 Gbytes (see Section 2.2 and 2.3 for related information).	ST9500327AS = 0FFFFFFh ST9320327AS = 0FFFFFFh ST9250317AS = 0FFFFFFh ST9160317AS = 0FFFFFFh ST9120317AS = 234,441,648 ST980314AS = 156,301,488
62	Retired	0000 <sub>H</sub>
63	Multiword DMA active and modes supported (see note following this table)	xx07 <sub>H</sub>
64	Advanced PIO modes supported (modes 3 and 4 supported)	0003 <sub>H</sub>
65	Minimum multiword DMA transfer cycle time per word (120 nsec)	0078 <sub>H</sub>
66	Recommended multiword DMA transfer cycle time per word (120 nsec)	0078 <sub>H</sub>
67	Minimum PIO cycle time without IORDY flow control (240 nsec)	00F0 <sub>H</sub>
68	Minimum PIO cycle time with IORDY flow control (120 nsec)	0078 <sub>H</sub>
69–74	ATA-reserved	0000 <sub>H</sub>
75	Queue depth	0000 <sub>H</sub>
76	Serial ATA capabilities	0508 <sub>H</sub>
77	ATA-reserved	0000 <sub>H</sub>
78	Serial ATA features supported	0048 <sub>H</sub>
79	Serial ATA features enabled	0040 <sub>H</sub>
80	Major version number	003E <sub>H</sub>
81	Minor version number	0000 <sub>H</sub>
82	Command sets supported	306B <sub>H</sub>



<b>Word</b>	<b>Description</b>	<b>Value</b>
83	Command sets supported	4001 <sub>H</sub>
84	Command sets support extension	6123 <sub>H</sub>
85	Command sets enabled	30xx <sub>H</sub>
86	Command sets enabled	0001 <sub>H</sub>
87	Command sets enable extension	4000 <sub>H</sub>
88	Ultra DMA support and current mode (see note following this table)	xx7F <sub>H</sub>
89	Security erase time	0000 <sub>H</sub>
90	Enhanced security erase time	0001 <sub>H</sub>
92	Master password revision code	FFFE <sub>H</sub>
93	Hardware reset value (see description following this table)	xxxx <sub>H</sub>
94	Auto acoustic management setting	xxxx <sub>H</sub>
95–99	ATA-reserved	0000 <sub>H</sub>
100– 103	Total number of user-addressable LBA sectors available (see Section 2.2 for related information) These words are required for drives that support the 48-bit addressing feature. Maximum value: 0000FFFFFFFF <sub>H</sub> .	ST9500327AS = 976,773,168 ST9320327AS = 625,142,448 ST9250317AS = 488,397,168 ST9160317AS = 312,581,808 ST9120317AS = 234,441,648 ST980314AS = 156,301,488
104– 118	ATA-reserved	0000 <sub>H</sub>
119	Free Fall Protection support (bit 5)	1 = Free Fall Protection supported 0 = Free Fall Protection not supported
120	Free Fall Protection enable/disable (bit 5)	1 = Free Fall Protection is enabled 0 = Free Fall Protection is disabled
121– 127	ATA reserved	0000 <sub>H</sub>
128	Security status	0021 <sub>H</sub>
129– 159	Seagate-reserved	xxxx <sub>H</sub>
160– 254	ATA-reserved	0000 <sub>H</sub>
255	Integrity word	xxA5 <sub>H</sub>

**Note.** See the bit descriptions below for words 63, 88, 93 and 94 of the Identify Drive data:

<b>Description (if bit is set to 1)</b>		
	<b>Bit</b>	<b>Word 63</b>
	0	Multiword DMA mode 0 is supported.
	1	Multiword DMA mode 1 is supported.
	2	Multiword DMA mode 2 is supported.
	8	Multiword DMA mode 0 is currently active.
	9	Multiword DMA mode 1 is currently active.
	10	Multiword DMA mode 2 is currently active.
	<b>Bit</b>	<b>Word 88</b>
	0	Ultra DMA mode 0 is supported.
	1	Ultra DMA mode 1 is supported.
	2	Ultra DMA mode 2 is supported.
	3	Ultra DMA mode 3 is supported.
	4	Ultra DMA mode 4 is supported.
	8	Ultra DMA mode 0 is currently active.
	9	Ultra DMA mode 1 is currently active.
	10	Ultra DMA mode 2 is currently active.
	11	Ultra DMA mode 3 is currently active.
	12	Ultra DMA mode 4 is currently active.
	13	Ultra DMA mode 5 is currently active.
	14	Ultra DMA mode 6 is currently active.
	<b>Bit</b>	<b>Word 93</b>
	13	1 = 80-conductor cable detected, CBLID above VIH 0 = 40-conductor cable detected, CBLID below VIL

#### 4.2.6 Set Features command

This command controls the implementation of various features that the drive supports. When the drive receives this command, it sets BSY, checks the contents of the Features register, clears BSY and generates an interrupt. If the value in the register does not represent a feature that the drive supports, the command is aborted. Power-on default has the read look-ahead and write caching features enabled. The acceptable values for the Features register are defined as follows:

**Table 10: Set Features command values**

02 <sub>H</sub>	Enable write cache ( <i>default</i> ).
03 <sub>H</sub>	Set transfer mode (based on value in Sector Count register). Sector Count register values:
00 <sub>H</sub>	Set PIO mode to default (PIO mode 2).
01 <sub>H</sub>	Set PIO mode to default and disable IORDY (PIO mode 2).
08 <sub>H</sub>	PIO mode 0
09 <sub>H</sub>	PIO mode 1
0A <sub>H</sub>	PIO mode 2
0B <sub>H</sub>	PIO mode 3
0C <sub>H</sub>	PIO mode 4 ( <i>default</i> )
20 <sub>H</sub>	Multiword DMA mode 0
21 <sub>H</sub>	Multiword DMA mode 1
22 <sub>H</sub>	Multiword DMA mode 2
40 <sub>H</sub>	Ultra DMA mode 0
41 <sub>H</sub>	Ultra DMA mode 1
42 <sub>H</sub>	Ultra DMA mode 2
43 <sub>H</sub>	Ultra DMA mode 3
44 <sub>H</sub>	Ultra DMA mode 4
45 <sub>H</sub>	Ultra DMA mode 5
46 <sub>H</sub>	Ultra DMA mode 6
55 <sub>H</sub>	Disable read look-ahead (read cache) feature.
82 <sub>H</sub>	Disable write cache
AA <sub>H</sub>	Enable read look-ahead (read cache) feature ( <i>default</i> ).
F1 <sub>H</sub>	Report full capacity available

**Note.** At power-on, or after a hardware or software reset, the default values of the features are as indicated above.

#### 4.2.7 S.M.A.R.T. commands

S.M.A.R.T. provides near-term failure prediction for disc drives. When S.M.A.R.T. is enabled, the drive monitors predetermined drive attributes that are susceptible to degradation over time. If self-monitoring determines that a failure is likely, S.M.A.R.T. makes a status report available to the host. Not all failures are predictable. S.M.A.R.T. predictability is limited to the attributes the drive can monitor. For more information on S.M.A.R.T. commands and implementation, see the *Draft ATA-5 Standard*.

SeaTools diagnostic software activates a built-in drive self-test (DST S.M.A.R.T. command for D4<sub>H</sub>) that eliminates unnecessary drive returns. The diagnostic software ships with all new drives and is also available at: <http://seatools.seagate.com>.

This drive is shipped with S.M.A.R.T. features disabled. You must have a recent BIOS or software package that supports S.M.A.R.T. to enable this feature. The table below shows the S.M.A.R.T. command codes that the drive uses.

**Table 11: S.M.A.R.T. commands**

Code in features register	S.M.A.R.T. command
D0 <sub>H</sub>	S.M.A.R.T. Read Data
D1 <sub>H</sub>	Vendor-specific
D2 <sub>H</sub>	S.M.A.R.T. Enable/Disable Attribute Autosave
D3 <sub>H</sub>	S.M.A.R.T. Save Attribute Values
D4 <sub>H</sub>	S.M.A.R.T. Execute Off-line Immediate (runs DST)
D7 <sub>H</sub>	Vendor-specific
D8 <sub>H</sub>	S.M.A.R.T. Enable Operations
D9 <sub>H</sub>	S.M.A.R.T. Disable Operations
DA <sub>H</sub>	S.M.A.R.T. Return Status

**Note.** If an appropriate code is not written to the Features Register, the command is aborted and 0x04 (abort) is written to the Error register.

## 5.0 Compatibility summary

---

### 5.1 Installation considerations

Many of today's mobile computers have been designed to make it possible for the end user to replace the hard drive. Refer to your system's user manual for the location of the hard drive compartment and the specific instructions regarding replacement. Refer to your system manufacturer's support website for the most up-to-date information. Read and follow all instructions regarding the proper steps to be taken when replacing the system hard drive.

Some mobile systems are sealed and require specialized tools to gain access to the hard drive. Special training or tools may be needed to service some mobile computers. In some cases, opening the case may void your warranty. Consult your system documentation. Seagate recommends taking your system to an authorized service technician to replace your hard drive.

### 5.2 System Compatibility using Windows XP SP2

Seagate Product Assurance has tested Momentus drives in systems using ATA Security mode. Testing included multiple BIOS versions and the Windows XP SP2 Pro operating system. This testing was done to demonstrate compatibility with various hardware and software configurations.

#### 5.2.1 BIOS versions tested in ATA Security mode

The following list indicates the types of BIOS Seagate tested during the compatibility testing process. The list highlights the major BIOS manufacturers. Individual systems contain variations of these BIOS versions and were tested with regard to their implementation in the individual systems.

**Table 12: Tested BIOS versions with Windows XP SP2**

Manufacturer	Model	BIOS Vendor	BIOS Release	BIOS Version
AMD	K8	AMI	MSIA7207NMS	V3.00
AMD	K8	AMI	V02.59	
AMD	K8	AMI	VER 02.59	VER 08.00.13
AMD	K8	AWARD	6	P6
AMD	K8	AWARD	V1.B	11/28/2005
AMD	K8	AWARD	V6.00	P0
AMD	K8	AWARD	V6.00PG	
AMD	K8	AWARD	V6.00PG	11/17/2005
AMD	K8	HP	786B9	V2.00
AMD	K8	PHOENIX	AWARD	VER 6.00PG
AMD	K8	PHOENIX	6.00P	

**Table 12: Tested BIOS versions with Windows XP SP2**

<b>Manufacturer</b>	<b>Model</b>	<b>BIOS Vendor</b>	<b>BIOS Release</b>	<b>BIOS Version</b>
AMD	K8	PHOENIX	AWARD	V5.1.39
AMD	K8	PHOENIX	AWARD	V6.00PG
AMD	K8	PHOENIX	AWARD	
AMD	K8	PHOENIX	DELL	1.1.2
AMD	K8	PHOENIX	VER 2004Q3	
AMD	K8	PHOENIX		
ATI	0X5A31	INSYDE		R1.00
ATI	RS400-200	AMI	V02.59	
ATI	RS400-200	AMI	V0707	
ATI	RS480	AMERICAN MEGETRENDS	2/13/2006	
ATI	RS480	AMI	VER V3.1	
ATI	RS480	AWARD	3.13	11/15/2005
ATI	RS480	HP	VER1.09	11/22/2005
ATI	RS480	PHOENIX		V1.04
ATI	RS480	PHOENIX AWARD	V1.04	5/24/2005
INTEL	5000X	PHOENIX	DELL	A00
INTEL	865	GATEWAY	510A 15A.0027	
INTEL	865	GATEWAY	510A 15A.0043	
INTEL	865	GATEWAY	510A 15A.0045	
INTEL	865	GATEWAY	510A 15A.0066	
INTEL	865	HP	786B1	V1.14
INTEL	865	HP	786B2	2.43
INTEL	865	HP	786B2	V1.11
INTEL	865	HP	786B2	V2.04
INTEL	865	HP		1.11
INTEL	865	HP		786B2 V1.10
INTEL	865	IBM	2CKT20AUS	10/26/2004
INTEL	865	INTEL	510A.86A.0053	
INTEL	865	MICRON	510A.86A.003	
INTEL	865	MICRON	510A.86A.0033	
INTEL	865	PHOENIX	DELL	A04
INTEL	865	PHOENIX	DELL	A06
INTEL	865	PHOENIX	DELL	A08
INTEL	865	PHOENIX	DELL	A10
INTEL	865	PHOENIX		6
INTEL	875P	AWARD	4/23/2003	875P-6A79BG00C

**Table 12: Tested BIOS versions with Windows XP SP2**

<b>Manufacturer</b>	<b>Model</b>	<b>BIOS Vendor</b>	<b>BIOS Release</b>	<b>BIOS Version</b>
INTEL	875P	GATEWAY	510A.15A.0080	
INTEL	875P	HP	786B3	V1.09
INTEL	875P	MICRON	510A.86A.0076	
INTEL	875P	PHOENIX	DELL	A02
INTEL	875P	PHOENIX	DELL	A03
INTEL	915G/P	AMI	3.1	8.00.10 11/12/04
INTEL	915G/P	AMI	VVPGI635	5/6/2004
INTEL	915G/P	AMI	VVPGI635	
INTEL	915G/P	HP	786C1	V1.05
INTEL	915G/P	HP	786C2	V1.02
INTEL	915G/P	IBM		2/4/2005
INTEL	915G/P	MPC		EV91510A.86A.0308
INTEL	915G/P	PHOENIX	AWARD BIOS 6.00PG	R01-03
INTEL	915G/P	PHOENIX	DELL	A01
INTEL	915G/P	PHOENIX	DELL	A03
INTEL	915G/P	PHOENIX	DELL	A05
INTEL	915M	AMI		R0060F2
INTEL	915M	IBM		1.03A (77ET40WW)
INTEL	915M	PHOENIX	30/05/2005	1.05
INTEL	915M	PHOENIX	PHOENIX BIOS	1.06
INTEL	915M	PHOENIX		1.07
INTEL	915M	PHOENIX		R0071V0
INTEL	915M	PHOENIX		R0160X5
INTEL	925X	HP	786C3	V1.04
INTEL	925X	PHOENIX	DELL	A06
INTEL	945G/P	AWARD	NT94510J.86A.2487.2005.0906.1451	
INTEL	945G/P	HP	786D1	V1.03
INTEL	945G/P	PHOENIX	AWARD	V6.00PG
INTEL	945G/P	PHOENIX	DELL	A01
INTEL	945G/P	PHOENIX	DELL	A02
INTEL	945G/P	PHOENIX	DELL	A05
INTEL	945GM/PM	DELL		A02
INTEL	945GM/PM	DELL		A04
INTEL	945GM/PM	DELL		A05
INTEL	945GM/PM	DELL		A09
INTEL	945GM/PM	HP	F.05	

**Table 12: Tested BIOS versions with Windows XP SP2**

Manufacturer	Model	BIOS Vendor	BIOS Release	BIOS Version
INTEL	945GM/PM	IBM		1.02 (79ET56WW)
INTEL	945GM/PM	IBM		1.04 (7BET44WW)
INTEL	945GM/PM	LENOVO		1.02 (7CET47WW)
INTEL	945GM/PM	LENOVO		1.10 (7FET50WW)
INTEL	945GM/PM	LENOVO		2.00 (79ETC0WW)
INTEL	945GM/PM	PHOENIX		V1.20
INTEL	955X	AMI	206	12/21/2005
INTEL	955X	HP	786D3	V1.02
INTEL	955X	PHOENIX	AWARD	W7158IMS
INTEL	955X			
INTEL	975X	AMI	206	12/21/2005
INTEL	975X	AWARD	VER F1	
INTEL	E7221	PHOENIX	DELL	A00
INTEL	G/P965	INSYDE		
INTEL	G/P965	PHOENIX	1.0.3	8/14/2006
INTEL	G/P965	PHOENIX	DELL	1.0.3
INTEL	G/P965	PHOENIX	DELL	2.1.0
NVIDIA	0X0070	PHOENIX	V6.00PG	2/7/2006
NVIDIA	NFORCE 4SLI	AMI	V310	
NVIDIA	NFORCE 4SLI	PHOENIX	DELL	A04
NVIDIA	NFORCE 4SLI	PHOENIX	V6.00PG	7/11/2005
SIS	661	AWARD	R1.00	6/13/2005
SIS	760	AMI	V2.54	
SIS	760	PHOENIX	V3.01	8/18/2004
VIA	K8M800	AMI	V0210	
VIA	K8M800	AMI	V2.54	8/30/2005
VIA	K8M800	AWARD	V6.00PG	10/17/2005

### 5.2.2 DriveTrust compatibility verification

The systems documented in Table 13 passed DriveTrust compatibility tests running Windows XP Pro with service pack 2 (SP2). The system configurations listed below support the Trusted Send/Receive capabilities required for pre-boot and other SeaCOS (dcard) features. Refer to your DriveTrust software vendor for additional considerations.



**Table 13: DriveTrust compatibility**

Chipset Manufacturer	Chipset Southbridge	System Vendor	System Model	SATA Mode	BIOS
Intel	ICH6M	LG	LW40-DOX1	ATA	Phoenix OLMPSF07
		TCL	K40D	ATA	Phoenix1.00
	ICH7M	Acer	Aspire 3690 BL50	ATA	Phoenix V3.50
			Aspire 5572WXMI	ATA	Phoenix V1.3505
			Aspire 9410 MS2195	ATA	Phoenix V1.18
			Aspire 9800 LA01	ATA	Phoenix I1.05
			Aspire 9815WKH1	ATA	Phoenix V2.12
			Travelmate 3270-ZR1	ATA	Phoenix V1.3505
			6263	ATA	Phoenix 2.03
		Asus	F9J	ATA	Asus
			G2P	ATA	Asus 009.012.001.027.A07408.025
			R1F	ATA	Asus 13.13.106405.009
			V1JP	ATA	Asus V310
		Dell	Inspiron 6400/E1505	ATA	Dell A09
			Inspiron 9400/E1705	ATA	Dell A04
			Precision M65	ATA	Dell A05
			Precision M90	ATA	Dell A04
			XPS M1210	ATA	Dell A04
			XPS M1710	ATA	Dell A02
		Fujitsu	FMVNE2KD3	AHCI	Phoenix V1.09
			FMVNF70W	AHCI	Fujitsu Phoenix 1.04
			FMVNS5C4	AHCI	Fujitsu Phoenix 1.25
			FMVNX70WD	AHCI	Fujitsu Phoenix 1.06
			FMVNX90RW	AHCI	Phoenix V1.04
			Lifebook FMV8250	ATA	Phoenix V1.02
		Gateway	E-100M	AHCI	PhoenixBIOS 76.09
			M465-E	AHCI	PhoenixBIOS 71.04
			M685-E	AHCI	PhoenixBIOS 72.02
			NX560X	AHCI	PhoenixBIOS 71.04
		HP-BPC	Compaq NC4400	AHCI	HP F.08
	Compaq NC6400		AHCI	HP F.08	
	Compaq NC8430		AHCI	HP F.12	
	Compaq NW8440		AHCI	HP F.12	
	Compaq NW9440		AHCI	HP F.1B	
	Compaq NX7400		AHCI	HP	
	Compaq NX8420		AHCI	HP F.15	
	Compaq NX9420		AHCI	HP F.1C	
	Compaq TC4400		AHCI	HP F.0B	
	Pavilion DV2000T		AHCI	HP F26	
	Pavilion DV6000T		AHCI	HP F27	
	Pavilion DV9000T		AHCI	HP F27	

**Table 13: DriveTrust compatibility**

Chipset Manufacturer	Chipset Southbridge	System Vendor	System Model	SATA Mode	BIOS
Intel	ICH7M	HP-BPC	Presario V3000T	AHCI	HP F26
			Presario V6000T	AHCI	HP F.29
		Lenovo China	Sunrise 210	ATA	Phoenix Trustedcore 1.0B-1264-8A20
			Sunrise 410	ATA	Phoenix Trustedcore LE4 Q3B72
			Sunrise 410L	ATA	Phoenix Trustedcore LE4 Q3B72
			TIAN YI F30A	ATA	Phoenix Trustedcore Q3A82
			TIAN YI F40A	ATA	V1.08
			LG	LGE-DMLGR40(B)	AHCI
		NEC-SAS	NEC Versa M160	ATA	Phoenix 3A22-1284-1A22
			NEC Versa M360	ATA	Phoenix 3A22-1284-1A22
		Sony	VGN FE31B/W	ATA	Phoenix R0170J3
			VNG FE51B/H	ATA	Phoenix R0107J3
			VGN-AR92S	ATA	Phoenix
			VGN-C71B/W	ATA	Phoenix
			VGN-FE53B/W	ATA	Phoenix
			VGN-N51HB	ATA	Phoenix
			VGN-SZ73B/B	ATA	Phoenix N0G72-13
		TCL	K42	ATA	Phoenix 1.08
		Toshiba	Satelite M100	ATA	Phoenix V1.20
		ICH8M	Acer	AS9920	AHCI
	Aspire 4720			AHCI	Phoenix V1.08
	Aspire 5920G			AHCI	Phoenix V1.3708
	Aspire 5920G			AHCI	Acer
	Aspire 7720WSMI			AHCI	AMI V1.12
	Asus		G1S	AHCI	Asus
			G2S	ATA	Asus 1000B50001
	Dell		Inspiron 1420	AHCI	Phoenix A00
			Inspiron 1720	AHCI	Phoenix A00
			Precision M4300	ATA	Phoenix A02
			Precision M6300	AHCI	Phoenix A00
	Fujitsu		FMB BIBLO NF70X	AHCI	Phoenix V1.12
			FMVNE5FD4	AHCI	Fujitsu Phoenix 1.06
	Fujitsu Siemens	Celsius H250	AHCI	Phoenix 1.08	
Lifebook S6410		AHCI	Phoenix 1.11		

**Table 13: DriveTrust compatibility**

Chipset Manufacturer	Chipset Southbridge	System Vendor	System Model	SATA Mode	BIOS		
Intel	ICH8M	HP-BPC	Compaq 2210B	AHCI	HP F00		
			Compaq 6510B	AHCI	HP F10		
			Compaq 6710B	AHCI	HP F.0B		
			Compaq 6720S	AHCI	HP		
			Compaq 6910P	AHCI	HP F.06		
			Compaq 8710P	AHCI			
			Pavilion DV2500T	AHCI	Phoenix F.21		
			Pavilion DV6500T	AHCI	Phoenix F.33		
			Pavilion DV9500T	AHCI	Phoenix F.33		
			Pavilion HDX	AHCI	HP		
		Lenovo China	TIANYI F41A	ATA	Lenovo 05N23WW (V1.03)		
			XURI C430A	ATA	Lenovo Q3B14		
			XURI C430G	ATA	Lenovo Q3B14		
			ZHAOYANG K42A	AHCI	Lenovo 1.06T05		
		LG	LGE-DML GE50(B)	ATA	AMI A1636IL 1 V1.17		
			LGE-DML GM1(B)	ATA	Phoenix STNYSF05		
			LGE-DML GP3	AHCI	Phoenix COLSSF0B		
		Samsung	SEC-NT-R70(B)	ATA	Phoenix 05AB		
			SQ45S70S	ATA	Phoenix 06ST		
		TCL	T45	AHCI	Phoenix A 0B-0401-0011		
		Trigem	N8393WFGK	ATA	Phoenix 1.00TG		
		AMD(ATI)	SB600	Acer	Travelmate 5520G	ATA	Phoenix V1.14
				Dell	Inspiron 1521	ATA	Phoenix A00
Inspiron 1721	ATA				Phoenix 2 3.1		
Trigem	N8172SH1K			ATA	Phoenix 1.00		
Dell	Inspiron 1501			ATA	Dell 1.4.0		
Nvidia	MCP51	HP-BPC	Pavilion DV2000Z	ATA	HP F34		
			Pavilion DV6000Z	ATA	HP F38		
			Pavilion TX1000Z	ATA	HP F.18		
Nvidia	MCP51	HP-BPC	Pavilion TX1200	ATA	Phoenix F.1C		
			Presario V6000Z	ATA	HP F.38		

### 5.3 Operating system versions tested

This list indicates the types of Operating Systems Seagate tested during the compatibility testing process. Several variations of these operating systems have been tested.

**Table 14: Supported operating systems**

Manufacturer	Version/Release
Microsoft	Windows Server 2003 (Compatibility evaluated, but not tested)
Microsoft	Windows XP, XP Pro, XP Home (Service Pack 2) (multiple languages)
Microsoft	Windows Vista. Note: Some systems will require a "hotfix" from Microsoft. Refer to <a href="http://www.microsoft.com">www.microsoft.com</a> and search for knowledgebase (KB) article number 943170 for important information about obtaining and installing the necessary operating system fixes necessary to successfully use Vista with FDE drives in DriveTrust mode. These fixes are not required to use the drive in ATA Security mode.

### 5.4 Compatibility test configurations

Tests are performed to ensure functionality to the ATA/ATAPI-7 specification and are constantly evolving to match the evolution of the ATA/ATAPI specifications. Momentus 5400 FDE.4 SATA drives should be expected to be largely compliant to the emerging ATA/ATAPI-8 specification.

Exceptions to the specifications for the Momentus 5400 FDE.4 SATA drives are listed in Section 4.0.

## 6.0 Seagate Technology support services

---

### SEAGATE ONLINE SUPPORT and SERVICES

For information regarding products and services, visit [http://www.seagate.com/www/en-us/about/contact\\_us/](http://www.seagate.com/www/en-us/about/contact_us/)

Available services include:

- Presales & Technical support
- Global Support Services telephone numbers & business hours
- Authorized Service Centers

For information regarding Warranty Support, visit [http://www.seagate.com/www/en-us/support/warranty\\_&\\_returns\\_assistance](http://www.seagate.com/www/en-us/support/warranty_&_returns_assistance)

For information regarding Data Recovery Services, visit <http://www.i365.com>

For Seagate OEM & Distribution partner portal, visit <https://direct.seagate.com/portal/system>

For Seagate reseller portal, visit <http://spp.seagate.com>



# Index

## A

- ACA 16
- acoustics 5, 14
- Active mode 11
- AFR 15
- Agency certification 15
- Altitude 12
- Altitude, nonoperating 5
- Altitude, operating 5
- Ambient temperature 5, 12
- ambient temperature 8
- Annualized Failure Rate 15
- Annualized Failure Rate (AFR) 5
- Areal density 4, 7
- ATA data-transfer modes supported 4
- ATA-standard commands 30
- Australia/New Zealand Standard AS/NZS3548 1995 16
- Australian Communication Authority (ACA) 16
- Australian C-Tick 16
- Average seek time 8
- Average seek, read 5

## B

- bels 5
- BIOS manufacturers 39
- BPI 4
- buffer 1, 4, 7
- burst 1
- Bytes per sector 4, 6

## C

- cables and connectors 19
- Cache 4
- cache 1, 7
- capacity 6
- case temperature 12
- CE mark 15
- certification 15
- chemical substances 17
- China RoHS directive 17
- Class B computing device 16
- commands 30
- compatibility 15, 39
- compatibility summary 39
- compatibility test configurations 46
- Conducted noise 10
- Conducted RF immunity 14
- Configuring the drive 18
- connectors 19
- CSA C22.2 (950) 15

- current 5
- cycles 15
- Cylinders 6

## D

- data-transfer rates 1
- DC power 9
- Default logical geometry 6
- density 4
- diagnostic software 1
- dimensions 21
- Discs 4
- dissipation 9
- drive monitoring 1
- drive self-test 1

## E

- Electrical fast transient 14
- Electromagnetic compatibility 15
- Electromagnetic Compatibility Directive (89/336/EEC) 15
- Electromagnetic immunity 14
- Electrostatic discharge 14
- electrostatic discharge (ESD) 18
- EN 55022, Class B 15
- EN 55024 15
- EN 60950 15
- Environmental protection 17
- Environmental specifications 12
- error-correction algorithms 1
- errors 5, 15
- ESD 18
- EU 15
- European Union (EU) requirements 15
- European Union Restriction of Hazardous Substances 17

## F

- FCC verification 16
- Federal Communications Commission 16
- Formatted capacity 6
- Formatted Gbytes 4

## G

- Gbytes 6
- geometry 6
- gradient 5
- Guaranteed sectors 4, 6
- guaranteed sectors 6

## H

- handling 18
- Handling precautions 18

heads 6  
Height 4  
height 7  
Humidity 12  
humidity 5

## I

I/O data-transfer rate 4, 7  
Identify Device command 33  
Idle 9  
Idle and Standby timers 11  
Idle mode 5, 11  
Idle mode power 9  
IEC950 15  
Information Technology Equipment (ITE) 15  
Input noise ripple 10  
Interface 7  
interface 25  
Interleave 7  
Internal data transfer rate 4  
Internal data-transfer rate 7  
ITE 15

## K

Korean RRL 16

## L

latency 4  
LBA mode 6  
Length 4  
length 7  
Load/Unload 15  
logical geometry 6

## M

maximum temperature 12  
monitoring 1  
mounting 20  
mounting screws 13  
mounting the drive 18

## N

noise 10  
nominal power 8  
Nonoperating shock 13  
Nonoperating vibration 13  
Nonrecoverable read errors 5  
nonrecoverable read errors 15

## O

Operating shock 13  
operating system 39

Operating vibration 13  
OS manufacturers 46

## P

Physical characteristics 7  
Physical organization 7  
Physical read/write heads 4  
point-to-point 19  
Power consumption 9  
power dissipation 9  
power management 11  
power on/off cycles 15  
Power specifications 9  
Power-management modes 11  
Power-on to Ready 8  
Power-on to ready 4  
precautions 18, 20  
programmable power management 11

## Q

quick reference 4

## R

Radiated RF immunity 14  
Radio and television interference 16  
radio frequency (RF) 14  
random track location 9  
read errors 5, 15  
Read Multiple 1  
Read/write heads 6  
Read/write power 5  
read/write power and current 9  
Recording density 4, 7  
Recording method 7  
Recording technology 7  
Relative humidity 5, 12  
Reliability 15  
resistance 10  
RF 14  
RoHS 17  
RPM 4  
RRL 16

## S

S.M.A.R.T. drive monitoring 1  
Safety certification 15  
SATA 7, 25  
screws 13, 20  
SeaTools 1  
sector 6  
sectors 6  
Sectors per track 6  
seek mode 9



Seek power 5  
Seek time 8  
seek time 5  
Seeking 9  
Self refresh, low power 11  
Serial ATA 7  
Serial ATA (SATA) interface 25  
servo electronics 9  
Shock 13  
Shock, nonoperating 5  
Shock, operating 5  
single-track seeks 8  
Sleep 9  
Sleep mode 5, 11  
sound power 5  
Specification summary table 4  
Spindle speed 4, 7  
Spinup 9  
spinup power 9  
Standby 9  
Standby mode 5, 9, 11  
Standby to Ready 8  
Standby to ready 4  
Start/stop times 8  
Startup current 5  
static-discharge 18  
support services 47  
Surge immunity 14

## **T**

technical support services 47  
temperature 5, 8, 12  
Temperature gradient 5, 12  
timers 11  
TPI 4  
Track density 4, 7  
Track-to-track seek time 5, 8  
TUV SUD PSB Singapore 15

## **U**

UL 1950 15  
UL Singapore 15

## **V**

Vibration 13  
Vibration, nonoperating 5  
Vibration, operating 5  
Voltage dips, interrupts 14  
Voltage tolerance 5, 10

## **W**

Warranty 15  
Weight 4

weight 7  
Wet bulb temperature 5, 12  
Width 4  
width 7  
Write Multiple 1







**Seagate Technology LLC**  
**920 Disc Drive, Scotts Valley, California 95066-4544, USA**  
*Publication Number: 100562041, Rev. C*