

A decorative graphic on the left side of the page, featuring a large dashed circle, a solid blue circle, and several overlapping curved lines in light blue and grey.

Product Manual

# Momentum®

7200-RPM

## Standard models

**ST9750420AS**

**ST9750422AS**

**ST9500423AS**

**ST9500424AS**

## Free-fall sensor models

**ST9750420ASG**

**ST9500423ASG**

GEN-5  
100610629  
Rev. B  
November 2010

## Revision history

Revision	Date	Sheets affected or comments
Rev. A	04/12/10	Initial release.
Rev. B	11/03/10	fc, 2, 5, 7, 9-10, 14, 17 & 28-30.

© 2010 Seagate Technology LLC. All rights reserved.

Publication number: 100610629, Rev. B, November 2010

Seagate, Seagate Technology and the Wave logo are registered trademarks of Seagate Technology LLC in the United States and/or other countries. Momentus and SeaTools are either trademarks or registered trademarks of Seagate Technology LLC or one of its affiliated companies in the United States and/or other countries. All other trademarks or registered trademarks are the property of their respective owners.

No part of this publication may be reproduced in any form without written permission of Seagate Technology LLC. Call 877-PUB-TEK1(877-782-8351) to request permission.

One gigabyte, or GB, equals one billion bytes and one terabyte, or TB, equals one trillion bytes. Your computer's operating system may use a different standard of measurement and report a lower capacity. In addition, some of the listed capacity is used for formatting and other functions, and thus will not be available for data storage. Seagate reserves the right to change, without notice, product offerings or specifications

# Contents

<b>1.0</b>	<b>Seagate Technology support services</b>	<b>1</b>
<b>2.0</b>	<b>Introduction</b>	<b>2</b>
2.1	About the Serial ATA interface	3
<b>3.0</b>	<b>Drive specifications</b>	<b>4</b>
3.1	Specification summary table	4
3.2	Formatted capacity	7
3.2.1	LBA mode	7
3.3	Default logical geometry	7
3.4	Physical organization	7
3.5	Recording and interface technology	8
3.6	Physical characteristics	8
3.7	Seek time	9
3.8	Start/stop times	9
3.9	Power specifications	10
3.9.1	Power consumption	10
3.9.2	Conducted noise	12
3.9.3	Voltage tolerance	12
3.9.4	Power-management modes	13
3.10	Environmental specifications	14
3.10.1	Ambient temperature	14
3.10.2	Temperature gradient	14
3.10.3	Relative humidity	14
3.10.4	Wet bulb temperature	14
3.10.5	Altitude	14
3.10.6	Shock	14
3.10.7	Vibration	15
3.11	Acoustics	15
3.12	Electromagnetic immunity	16
3.13	Reliability	16
3.13.1	Free Fall Protection feature	17
3.14	Agency certification	17
3.14.1	Safety certification	17
3.14.2	Electromagnetic compatibility	17
3.14.3	FCC verification	18
3.15	Environmental protection	19
3.15.1	European Union Restriction of Hazardous Substances (RoHS)	19
3.15.2	China Restriction of Hazardous Substances (RoHS) Directive	19
3.16	Corrosive environment	20
<b>4.0</b>	<b>Configuring and mounting the drive</b>	<b>21</b>
4.1	Handling and static-discharge precautions	21
4.2	Configuring the drive	22
4.3	Serial ATA cables and connectors	22
4.4	Drive mounting	23
<b>5.0</b>	<b>Serial ATA (SATA) interface</b>	<b>24</b>
5.1	Hot-Plug compatibility	24
5.2	Serial ATA device plug connector pin definitions	25
5.3	Supported ATA commands	26
5.3.1	Identify Device command	28
5.3.2	Set Features command	32
5.3.3	S.M.A.R.T. commands	33



## List of Figures

Figure 1.	Typical +5V only startup and operation current profile . . . . .	11
Figure 2.	Serial ATA connectors . . . . .	22
Figure 3.	Attaching SATA cabling . . . . .	22
Figure 4.	Mounting dimensions—top, side and end view . . . . .	23



## 1.0 Seagate Technology support services

---

### SEAGATE ONLINE SUPPORT and SERVICES

For information regarding products and services, visit [http://www.seagate.com/www/en-us/about/contact\\_us/](http://www.seagate.com/www/en-us/about/contact_us/)

Available services include:

- Presales & Technical support
- Global Support Services telephone numbers & business hours
- Authorized Service Centers

For information regarding Warranty Support, visit [http://www.seagate.com/www/en-us/support/warranty\\_&\\_returns\\_assistance](http://www.seagate.com/www/en-us/support/warranty_&_returns_assistance)

For information regarding Data Recovery Services, visit <http://www.i365.com>

For Seagate OEM & Distribution partner portal, visit <https://direct.seagate.com/portal/system>

For Seagate reseller portal, visit <http://spp.seagate.com>

## 2.0 Introduction

---

This manual describes the functional, mechanical and interface specifications for the following Seagate Momentus® model drives:

Standard models	Free Fall Protection models
ST9750420AS	ST9750420ASG
ST9750422AS	
ST9500423AS	ST9500423ASG
ST9500424AS	

These drives provide the following key features:

- 7200-RPM spindle speed.
- 16MB buffer.
- Free Fall Protection (on ST9750420ASG and ST9500423ASG models only)
- Quiet operation. Fluid Dynamic Bearing (FDB) motor.
- High instantaneous (burst) data-transfer rates (up to 3Gb/s).
- Perpendicular recording technology.
- State-of-the-art cache and on-the-fly error-correction algorithms.
- Native Command Queuing (NCQ) with command ordering.
- Full-track multiple-sector transfer capability without local processor intervention.
- 1000 Gs nonoperating shock and 350 Gs of operating shock.
- SeaTools diagnostic software performs a drive self-test that eliminates unnecessary drive returns.
- The 3D Defense System™, which includes Drive Defense, Data Defense and Diagnostic Defense, offers the industry's most comprehensive protection for disc drives.
- Support for S.M.A.R.T. drive monitoring and reporting.
- Support for Read Multiple and Write Multiple commands.



## 2.1 About the Serial ATA interface

The Serial ATA interface provides several advantages over the traditional (parallel) ATA interface. The primary advantages include:

- Easy installation and configuration with true plug-and-play connectivity. It is not normally necessary to set any jumpers or other configuration options.
- Thinner and more flexible cabling for improved enclosure airflow and ease of installation.
- Scalability to higher performance levels.

In addition, Serial ATA makes the transition from parallel ATA easy by providing legacy software support. Serial ATA was designed to allow you to install a Serial ATA host adapter and Serial ATA disc drive in your current system and expect all of your existing applications to work as normal.

The Serial ATA interface connects each disc drive in a point-to-point configuration with the Serial ATA host adapter. There is no master/slave relationship with Serial ATA devices like there is with parallel ATA. If two drives are attached on one Serial ATA host adapter, the host operating system views the two devices as if they were both “masters” on two separate ports. This essentially means both drives behave as if they are Device 0 (master) devices.

**Note.** The host adapter may, optionally, emulate a master/slave environment to host software where two devices on separate Serial ATA ports are represented to host software as a Device 0 (master) and Device 1 (slave) accessed at the same set of host bus addresses. A host adapter that emulates a master/slave environment manages two sets of shadow registers. This is not a typical Serial ATA environment.

The Serial ATA host adapter and drive share the function of emulating parallel ATA device behavior to provide backward compatibility with existing host systems and software. The Command and Control Block registers, PIO and DMA data transfers, resets, and interrupts are all emulated.

The Serial ATA host adapter contains a set of registers that shadow the contents of the traditional device registers, referred to as the Shadow Register Block. All Serial ATA devices behave like Device 0 devices. For additional information about how Serial ATA emulates parallel ATA, refer to the “Serial ATA: High Speed Serialized AT Attachment” specification. The specification can be downloaded from <http://www.serialata.org>.

## **3.0 Drive specifications**

---

Unless otherwise noted, all specifications are measured under ambient conditions, at 25°C, and nominal power.

### **3.1 Specification summary table**

The specifications listed in this table are for quick reference. For details on specification measurement or definition, see the appropriate section of this manual.

**Table 1: Drive specifications for 750 and 500 GB models**

Drive specification	ST9750422AS ST9750420AS ST9750420ASG	ST9500424AS ST9500423AS ST9500423ASG
Formatted GB	750	500
Guaranteed sectors	1,465,149,168	976,773,168
Bytes per sector (logical/physical)	512/4K	
Physical read/write heads	4	4/3
Discs	2	
Cache (MB)	16	
Recording density in BPI (max)	1,586k	
Track density TPI (tracks/inch max)	341k	
Areal density (Gb/in <sup>2</sup> max)	541	
Spindle speed (RPM)	7200	
Average latency (ms)	4.2	
Internal transfer rate (Gb/s max)	1305	
I/O data transfer rate (Gb/s max)	3.0	
ATA data-transfer modes supported	SATA 1.0, Serial ATA Revision 2.6 PIO modes 0–4 Multiword DMA modes 0–2 Ultra DMA modes 0–6	
Height	9.5 +/- 0.2 mm (0.370 +/- .008 in)	
Width	69.85 +/- 0.25 mm (2.750 +/- 0.010 in)	
Length	100.35 +0.20 / -0.25 mm (3.951 +0.008 / -0.010 in)	
Weight	115 g (0.254 lb)	
Power-on to ready (sec typical)	4.0	
Standby to ready (sec typical)	3.0	
Track-to-track seek time, read (ms typ)	1.5	
Average seek, read (ms typical)	11.0	
Average seek, write (ms typical)	13.0	
Startup current, +5V (max)	1.0A	
Seek power (typical)	2.5W	
Read power (typical)	2.1W	
Write power (typical)	2.4W	
Idle mode, low power (typical)	0.70W	
Standby mode (typical)	0.15W ***	
Sleep mode (typical)	0.15W ***	
Voltage tolerance (including noise)	+5V ± 5%	
Ambient temperature	0°C to 60°C (operating) –40°C to 70°C (nonoperating)	
Temperature gradient (°C/hour max)	20°C (operating), 35°C (nonoperating)	
Relative humidity	5% to 95% (operating and nonoperating)	
Relative humidity gradient	30% per hour max	
Wet bulb temperature (°C max)	37.7 °C (operating), 40 °C (nonoperating)	
Altitude, operating	–304.8 m to 3,048 m (–1,000 ft to 10,000+ ft)	
Altitude, nonoperating (meters below mean sea level, max)	–304.8 m to 12,192 m (–1000 ft to 40,000+ ft)	
Shock, operating (Gs max at 2 ms)	350	

**Table 1: Drive specifications for 750 and 500 GB models**

Drive specification	ST9750422AS ST9750420AS ST9750420ASG	ST9500424AS ST9500423AS ST9500423ASG
Shock, nonoperating (Gs max at 2 ms)	800	
Shock, nonoperating (Gs max at 1 msec)	1000	
Shock, nonoperating (Gs max at 0.5 ms)	1000	
Vibration, operating	2.0 G (0 to peak, 5–200 Hz) 1.0 G (0 to peak, 200–500 Hz)	
Vibration, nonoperating	5 Gs (0 to peak, 5–500 Hz)	
Drive acoustics, sound power (bels) Idle**	2.3 (typical) 2.5 (max)	
Performance seek	2.6 (typical) 2.7 (max)	
Nonrecoverable read errors	1 per 10 <sup>14</sup> bits read	
Annualized Failure Rate (AFR)	0.5%	
Load/Unload (U/UL) cycles  25°C, 50% relative humidity  32°C, 80% relative humidity 5°C, 80% relative humidity 5°C, 10% relative humidity 55°C, 16% relative humidity	600,000 software-controlled power on/off cycles 50,000 hard power on/off cycles  600,000 software-controlled power on/off cycles 50,000 hard power on/off cycles	
Warranty	To determine the warranty for a specific drive, use a web browser to access the following web page: <a href="http://www.seagate.com/www/en-us/support/warranty_&amp;_returns_assistance">http://www.seagate.com/www/en-us/support/warranty_&amp;_returns_assistance</a> From this page, click on the “Verify Your Warranty” link. You will be asked to provide the drive serial number, model number (or part number) and country of purchase. The system will display the warranty information for your drive.	
Supports Hotplug operation per Serial ATA Revision 2.6 specification	Yes (requires COMRESET from host after a hotplug event)	

\*One Gbyte equals one billion bytes when referring to hard drive capacity. Accessible capacity may vary depending on operating environment and formatting.

\*\*During periods of drive idle, some offline activity may occur according to the S.M.A.R.T. specification, which may increase acoustic and power to operational levels.

\*\*\*Typical notebooks will pull power to the drive when entering S3 and S4; while in the S3 and S4 states, drive sleep and drive standby modes will not contribute to battery power consumption.

## 3.2 Formatted capacity

Model	Formatted capacity*	Guaranteed sectors	Bytes per sector (logical)
ST9750422AS, ST9750420AS and ST9750420ASG	750GB	1,465,149,168	512
ST9500424AS, ST9500423AS and ST9500423ASG	500GB	976,773,168	

\*One Gbyte equals one billion bytes when referring to hard drive capacity. Accessible capacity may vary depending on operating environment and formatting.

### 3.2.1 LBA mode

When addressing these drives in LBA mode, all blocks (sectors) are consecutively numbered from 0 to  $n-1$ , where  $n$  is the number of guaranteed sectors as defined above.

See Section 5.3.1, "Identify Device command" (words 60-61 and 100-103) for additional information about 48-bit addressing support of drives with capacities over 137GB.

## 3.3 Default logical geometry

Cylinders	Read/write heads	Sectors per track
16,383	16	63

### LBA mode

When addressing these drives in LBA mode, all blocks (sectors) are consecutively numbered from 0 to  $n-1$ , where  $n$  is the number of guaranteed sectors as defined above.

## 3.4 Physical organization

Drive model	Read/write heads	Number of discs
ST9750422AS, ST9750420AS and ST9750420ASG	4	2
ST9500424AS, ST9500423AS and ST9500423ASG	4/3	

### 3.5 Recording and interface technology

Interface	Serial ATA (SATA)
Recording method	Perpendicular
Recording density BPI (bits/in max)	1,586k
Track density TPI (tracks/in max)	341k
Areal density (Gb/in <sup>2</sup> max)	541
Spindle speed (RPM) ( $\pm 0.2\%$ )	7200
Maximum Internal transfer rate (Gb/s)	1305
I/O data-transfer rate (Gb/s max)	3.0
Interleave	1:1
Cache buffer	16MB (16,384KB)

### 3.6 Physical characteristics

Drive specification		
Height	(mm) (in)	9.5 +/-0.2 0.370 +/-0.008
Width	(mm) (in)	69.85 +/-0.25 2.750 +/-0.010
Length	(mm) (in)	100.35 +0.20 / -0.25 3.951 +0.008 / -0.010
Typical weight all models		115 g 0.254 lb

### 3.7 Seek time

Seek measurements are taken with nominal power at 25°C ambient temperature. All times are measured using drive diagnostics. The specifications in the table below are defined as follows:

- Track-to-track seek time is an average of all possible single-track seeks in both directions.
- Average seek time is a true statistical random average of at least 5000 measurements of seeks between random tracks, less overhead.

**Table 2: Typical seek times**

Typical seek times (ms)	Read
Track-to-track	1.5
Average	11.0
Full-stroke	22.0
Average latency	4.2

**Note.** These drives are designed to consistently meet the seek times represented in this manual. Physical seeks, regardless of mode (such as track-to-track and average), are expected to meet the noted values. However, due to the manner in which these drives are formatted, benchmark tests that include command overhead or measure logical seeks may produce results that vary from these specifications.

### 3.8 Start/stop times

Time to ready	Typical	Max @ 25°C
Power-on to Ready (sec)	4.0	5.5
Standby to Ready (sec)	3.0	4.5

### 3.9 Power specifications

The drive receives DC power (+5V) through a native SATA power connector.

#### 3.9.1 Power consumption

Power requirements for the drives are listed in the table on page 10. Typical power measurements are based on an average of drives tested, under nominal conditions, at 25°C ambient temperature.

- **Spinup power**

Spinup power is measured from the time of power-on to the time that the drive spindle reaches operating speed.

- **Seek mode**

During seek mode, the read/write actuator arm moves toward a specific position on the disc surface and does not execute a read or write operation. Servo electronics are active. Seek mode power is measured based on three random seek operations every 100 ms. This mode is not typical.

- **Read/write power and current**

Read/write power is measured with the heads on track, based on three 63 sector read or write operations every 100 msecs.

- **Idle mode power**

Idle mode power is measured with the drive up to speed, with servo electronics active and with the heads in a random track location.

- **Standby mode**

During Standby mode, the drive accepts commands, but the drive is not spinning, and the servo and read/write electronics are in power-down model

**Table 3: DC power**

Power dissipation	+5V input average (25° C)
Spinup (max)	1.0A
Seek	2.5W
Read	2.1W
Write	2.4W
Idle, performance*	2.0W
Idle, active*	0.96W
Idle, low power mode*	0.70W
Standby	0.15W
Sleep	0.15W

\*During periods of drive idle, some offline activity may occur according to the S.M.A.R.T. specification, which may increase acoustic and power to operational levels.



### 3.9.1.1 Typical current profile

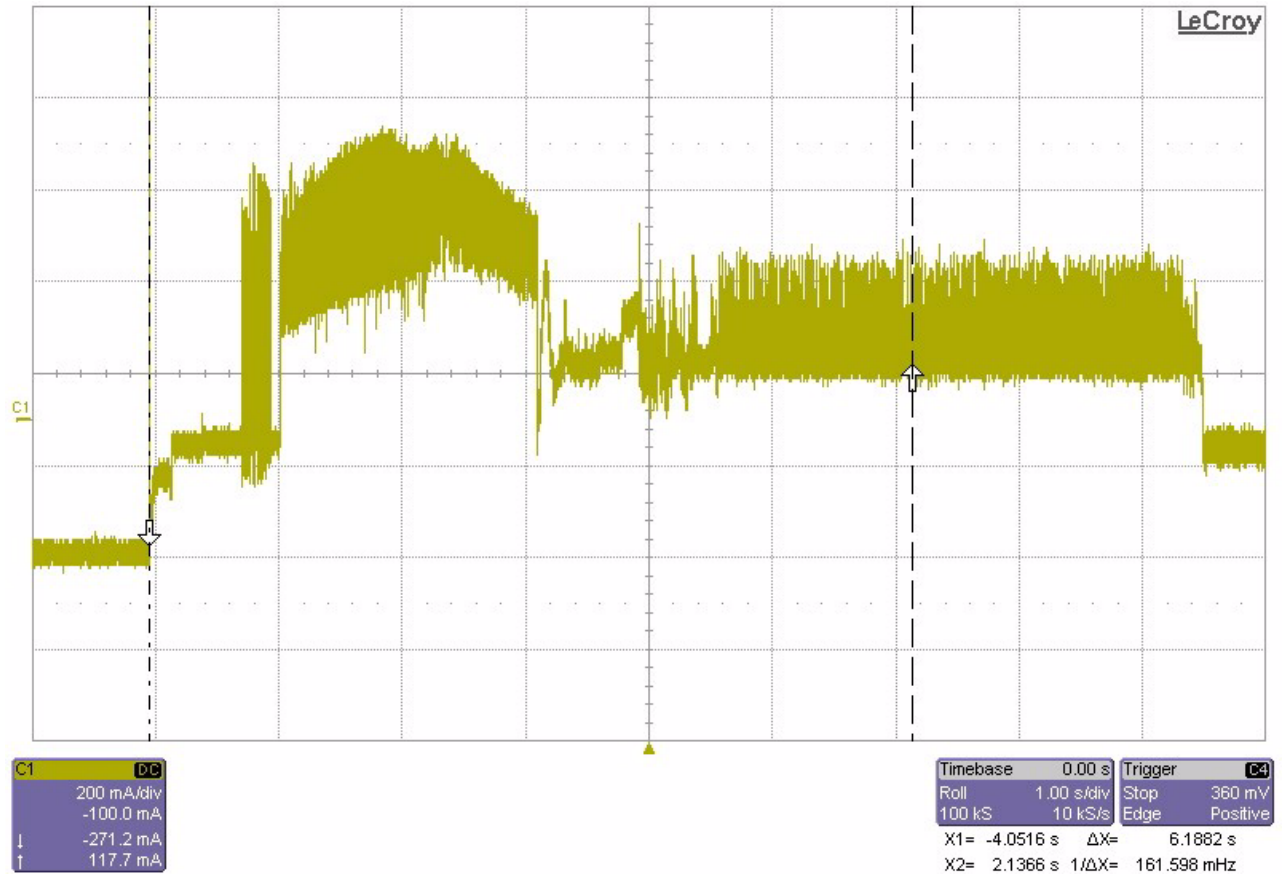

Figure 1. Typical +5V only startup and operation current profile

### 3.9.2 Conducted noise

Input noise ripple is measured at the host system power supply across an equivalent 15-ohm resistive load on the +5V line.

Using 5V power, the drive is expected to operate with a maximum of 100mV peak-to-peak square-wave injected noise at up to 10 MHz.

**Note.** Equivalent resistance is calculated by dividing the nominal voltage by the typical RMS read/write current.

### 3.9.3 Voltage tolerance

Voltage tolerance (including noise):

5V  $\pm$  5%

### 3.9.4 Power-management modes

The drive provides programmable power management to provide greater energy efficiency. In most systems, you can control power management through the system setup program. The drive features the following power-management modes:

**Table 4: Power management modes**

Power modes	Heads	Spindle	Buffer
Active (operating)	Tracking	Rotating	Full power
Idle, performance	Tracking	Rotating	Self refresh—low power
Idle, active	Floating	Rotating	Self refresh—low power
Idle, low power	Parked	Rotating	Self refresh—low power
Standby	Parked	Stopped	Self refresh—low power
Sleep	Parked	Stopped	Self refresh—low power

- **Active mode**

The drive is in Active mode during the read/write and seek operations.

- **Idle mode**

The buffer remains enabled, and the drive accepts all commands and returns to Active mode any time disc access is necessary.

- **Standby mode**

The drive enters Standby mode when the host sends a Standby Immediate command. If the host has set the standby timer, the drive can also enter Standby mode automatically after the drive has been inactive for a specifiable length of time. The standby timer delay is established using a Standby or Idle command. In Standby mode, the drive buffer is in Self Refresh Low Power mode, the heads are parked and the spindle is at rest. The drive accepts all commands and returns to Active mode any time disc access is necessary.

- **Sleep mode**

The drive enters Sleep mode after receiving a Sleep command from the host. In Sleep mode, the drive buffer is in Self Refresh Low Power mode, the heads are parked and the spindle is at rest. The drive leaves Sleep mode after it receives a Hard Reset or Soft Reset from the host. After receiving a reset, the drive exits Sleep mode and enters Standby mode with all current translation parameters intact.

- **Idle and Standby timers**

Each time the drive performs an Active function (read, write or seek), the standby timer is reinitialized and begins counting down from its specified delay times to zero. If the standby timer reaches zero before any drive activity is required, the drive makes a transition to Standby mode. In both Idle and Standby mode, the drive accepts all commands and returns to Active mode when disc access is necessary.

### 3.10 Environmental specifications

This section provides the temperature, humidity, shock, and vibration specifications for Momentus drives.

#### 3.10.1 Ambient temperature

Ambient temperature is defined as the temperature of the environment immediately surrounding the drive. Actual drive case temperature should not exceed 65°C (149°F) within the operating ambient conditions.

Above 1000 feet (305 meters), the maximum temperature is derated linearly by 1°C every 1000 feet.

Operating:	0°C to 60°C (32°F to 140°F)
Nonoperating:	–40°C to 70°C (–40°F to 158°F)

#### 3.10.2 Temperature gradient

Operating	20°C per hour (68°F per hour max), without condensation
Nonoperating	35°C per hour (95°F per hour max), without condensation

#### 3.10.3 Relative humidity

Operating	5% to 95% noncondensing (30% per hour max)
Nonoperating	5% to 95% noncondensing (30% per hour max)

#### 3.10.4 Wet bulb temperature

Operating	37.7°C (99.8°F max)
Nonoperating	40°C (104°F max)

#### 3.10.5 Altitude

Operating	–304.8 m to 3048 m (–1000 ft to 10,000+ ft)
Nonoperating	–304.8 m to 12,192 m (–1000 ft to 40,000+ ft)

#### 3.10.6 Shock

All shock specifications assume that the drive is mounted securely with the input shock applied at the drive mounting screws. Shock may be applied in the X, Y or Z axis.

**Note.** Additional shock protection is provided by the Free Fall Protection feature on ST9750420ASG and ST9500423ASG models. See Section 3.13.1 for additional information about this feature.

##### 3.10.6.1 Operating shock

These drives comply with the performance levels specified in this document when subjected to a maximum operating shock of 350 Gs based on half-sine shock pulses of 2ms. Shocks should not be repeated more than one time per axis.

### 3.10.6.2 Nonoperating shock

The nonoperating shock level that the drive can experience without incurring physical damage or degradation in performance when subsequently put into operation is 800 Gs based on a nonrepetitive half-sine shock pulse of 2 ms duration.

The nonoperating shock level that the drive can experience without incurring physical damage or degradation in performance when subsequently put into operation is 1000 Gs based on a nonrepetitive half-sine shock pulse of 1 ms duration.

The nonoperating shock level that the drive can experience without incurring physical damage or degradation in performance when subsequently put into operation is 1000 Gs based on a nonrepetitive half-sine shock pulse of 0.5 ms duration.

### 3.10.7 Vibration

All vibration specifications assume that the drive is mounted securely with the input vibration applied at the drive mounting screws. Vibration may be applied in the X, Y or Z axis.

#### 3.10.7.1 Operating vibration

The maximum vibration levels that the drive may experience while meeting the performance standards specified in this document are specified below.

5–200 Hz	2.0 Gs (0 to peak). Max displacement may apply below 10 Hz.
200–500 Hz	1.0 Gs (0 to peak).

#### 3.10.7.2 Nonoperating vibration

The maximum nonoperating vibration levels that the drive may experience without incurring physical damage or degradation in performance when subsequently put into operation are specified below.

5–500 Hz:	5 Gs (0 to peak). Max displacement may apply below 22 Hz.
-----------	---

### 3.11 Acoustics

Drive emission of sound is measured consistent with the ECMA-74 and its referenced standards. Testing is conducted at room temperature (approximately 25°C). Emission levels are reported as the total A-weighted sound power levels for steady state, idle, and active seeks modes of operation.

**Table 5: Drive A-weighted Sound Power Levels (SWL, BA)**

Idle*	Performance seek
2.3 bels (typ) 2.5 bels (max)	2.6 bels (typ) 2.7 bels (max)

\*During periods of drive idle, some offline activity may occur according to the S.M.A.R.T. specification, which may increase acoustic and power to operational levels.

#### Test for Prominent Discrete Tones (PDTs)

Seagate follows the ECMA-74 standards for measurement and identification of PDTs. An exception to this process is the use of the absolute threshold of hearing. Seagate uses the lower limit for the threshold curve\* to discern tone audibility and to compensate for the inaudible components of sound prior to computation of tone ratios according to Annex D of the ECMA-74 standards.

\*Defined as the median curve given by ISO 389-7 (Tf curve) minus 10dB at all frequencies.

### 3.12 Electromagnetic immunity

When properly installed in a representative host system, the drive operates without errors or degradation in performance when subjected to the radio frequency (RF) environments defined in the following table:

**Table 6: Radio frequency environments**

Test	Description	Performance level	Reference standard
Electrostatic discharge	Contact, HCP, VCP: ± 4 kV; Air: ± 8 kV	B	EN 61000-4-2: 95
Radiated RF immunity	80 to 1,000 MHz, 3 V/m, 80% AM with 1 kHz sine 900 MHz, 3 V/m, 50% pulse modulation @ 200 Hz	A	EN 61000-4-3: 96 ENV 50204: 95
Electrical fast transient	± 1 kV on AC mains, ± 0.5 kV on external I/O	B	EN 61000-4-4: 95
Surge immunity	± 1 kV differential, ± 2 kV common, AC mains	B	EN 61000-4-5: 95
Conducted RF immunity	150 kHz to 80 MHz, 3 Vrms, 80% AM with 1 kHz sine	A	EN 61000-4-6: 97
Power Frequency H-field immunity	1 A/m, 50Hz/60Hz, 3 axes	A	EN 61000-4-8: 97
Voltage dips, interrupts	30% Reduction for 25 cycles >95% Reduction for 250 cycles >95%, 0.5 cycles	C C B	EN 61000-4-11: 94

### 3.13 Reliability

Measurement type	Specification
Nonrecoverable read errors	1 per 10 <sup>14</sup> bits read, max.
Annualized Failure Rate (AFR)	0.5%
Load/Unload (U/UL)  25°C, 50% relative humidity  32°C, 80% relative humidity 5°C, 80% relative humidity 5°C, 10% relative humidity 55°C, 16% relative humidity	600,000 software-controlled power on/off cycles 50,000 hard power on/off cycles  600,000 software-controlled power on/off cycles 50,000 hard power on/off cycles
Warranty	To determine the warranty for a specific drive, use a web browser to access the following web page: <a href="http://www.seagate.com/www/en-us/support/warranty_&amp;_returns_assistance">http://www.seagate.com/www/en-us/support/warranty_&amp;_returns_assistance</a> From this page, click on the “Verify Your Warranty” link. You will be asked to provide the drive serial number, model number (or part number) and country of purchase. The system will display the warranty information for your drive.

### **3.13.1 Free Fall Protection feature**

The Free Fall Protection feature provides enhanced data protection against shock events that may occur while the drive is operating. This feature is designed to decrease the likelihood of data loss by detecting a free fall event and unloading the actuator before a shock takes place in falls of >8 inches (nominal). The drive uses a 0G sensor mounted on the printed circuit board assembly (PCBA) to sense this event.

To enable the Free Fall Protection feature on ST9750420ASG and ST9500423ASG models, use Set Features command 41h. To disable this feature, use Set Features command C1h.

Information about Free Fall Events that have occurred is available through SMART Attribute FEh.

**Note.** The Free Fall Protection feature is provided only on ST9750420ASG and ST9500423ASG models.

## **3.14 Agency certification**

### **3.14.1 Safety certification**

The drives are recognized in accordance with UL 60950-1 and CSA C22.2 (950) and meet all applicable sections of IEC 60950-1 and EN60950-1 as tested by TUV North America.

### **3.14.2 Electromagnetic compatibility**

Hard drives that display the CE mark comply with the European Union (EU) requirements specified in the Electromagnetic Compatibility Directive (89/336/EEC). Testing is performed to the levels specified by the product standards for Information Technology Equipment (ITE). Emission levels are defined by EN 55022, Class B and the immunity levels are defined by EN 55024.

Seagate uses an independent laboratory to confirm compliance with the EC directives specified in the previous paragraph. Drives are tested in representative end-user systems. Although CE-marked Seagate drives comply with the directives when used in the test systems, we cannot guarantee that all systems will comply with the directives. The drive is designed for operation inside a properly designed enclosure, with properly shielded I/O cable (if necessary) and terminators on all unused I/O ports. Computer manufacturers and system integrators should confirm EMC compliance and provide CE marking for their products.

### **Korean BCC**

If these drives have the Korea Ministry of Information and Communication (MIC) logo, they comply with paragraph 1 of Article 11 of the Electromagnetic Compatibility control Regulation and meet the Electromagnetic Compatibility (EMC) Framework requirements of the Broadcasting Communications Center (BCC) Ministry of Information and Communication Republic of Korea.

These drives have been tested and comply with the Electromagnetic Interference/Electromagnetic Susceptibility (EMI/EMS) for Class B products. Drives are tested in a representative, end-user system by a Korean-recognized lab.

- Certificate number: STX-Momentus (B)
- Trade name or applicant: Seagate Technology International (Wuxi) Co., Ltd.
- Date of certificate: May 25, 2009
- Manufacturer/nationality: Seagate Technology (Suzhou) Co., Ltd.

### **Australian C-Tick (N176)**

If these models have the C-Tick marking, they comply with the Australia/New Zealand Standard AS/NZS3548 1995 and meet the Electromagnetic Compatibility (EMC) Framework requirements of the Australian Communication Authority (ACA).

### 3.14.3 FCC verification

These drives are intended to be contained solely within a personal computer or similar enclosure (not attached as an external device). As such, each drive is considered to be a subassembly even when it is individually marketed to the customer. As a subassembly, no Federal Communications Commission verification or certification of the device is required.

Seagate Technology LLC has tested this device in enclosures as described above to ensure that the total assembly (enclosure, disc drive, motherboard, power supply, etc.) does comply with the limits for a Class B computing device, pursuant to Subpart J, Part 15 of the FCC rules. Operation with noncertified assemblies is likely to result in interference to radio and television reception.

**Radio and television interference.** This equipment generates and uses radio frequency energy and if not installed and used in strict accordance with the manufacturer's instructions, may cause interference to radio and television reception.

This equipment is designed to provide reasonable protection against such interference in a residential installation. However, there is no guarantee that interference will not occur in a particular installation. If this equipment does cause interference to radio or television, which can be determined by turning the equipment on and off, you are encouraged to try one or more of the following corrective measures:

- Reorient the receiving antenna.
- Move the device to one side or the other of the radio or TV.
- Move the device farther away from the radio or TV.
- Plug the computer into a different outlet so that the receiver and computer are on different branch outlets.

If necessary, you should consult your dealer or an experienced radio/television technician for additional suggestions. You may find helpful the following booklet prepared by the Federal Communications Commission: *How to Identify and Resolve Radio-Television Interference Problems*. This booklet is available from the Superintendent of Documents, U.S. Government Printing Office, Washington, DC 20402. Refer to publication number 004-000-00345-4.



### 3.15 Environmental protection

Seagate designs its products to meet environmental protection requirements worldwide, including regulations restricting certain chemical substances.

#### 3.15.1 European Union Restriction of Hazardous Substances (RoHS)

Seagate designs its products to meet environmental protection requirements worldwide, including regulations restricting certain chemical substances. A new law, the European Union Restriction of Hazardous Substances (RoHS) Directive, restricts the presence of chemical substances, including Lead, Cadmium, Mercury, Hexavalent Chromium, PBB and PBDE, in electronic products, effective July 2006. This drive is manufactured with components and materials that comply with the RoHS Directive.

#### 3.15.2 China Restriction of Hazardous Substances (RoHS) Directive 中国限制危险物品的指令

This product has an Environmental Protection Use Period (EPUP) of 20 years. The following table contains information mandated by China's "Marking Requirements for Control of Pollution Caused by Electronic Information Products" Standard.



该产品具有20年的环境保护使用周期（EPUP）。下表包含了中国“电子产品所导致的污染的控制的记号要求”所指定的信息。

Name of Parts 部件名称	Toxic or Hazardous Substances or Elements 有毒有害物质或元素					
	Lead 铅 (Pb)	Mercury 汞 (Hg)	Cadmium 镉 (Cd)	Hexavalent Chromium 六价铬 (Cr6+)	Polybrominated Biphenyl 多溴联苯 (PBB)	Polybrominated Diphenyl Ether 多溴二苯醚 (PBDE)
PCBA	X	O	O	O	O	O
HDA	X	O	O	O	O	O

"O" indicates the hazardous and toxic substance content of the part (at the homogenous material level) is lower than the threshold defined by the China RoHS MCV Standard.

“O”表示该部件（于同类物品程度上）所含的危险和有毒物质低于中国RoHS MCV标准所定义的门槛值。

"X" indicates the hazardous and toxic substance content of the part (at the homogenous material level) is over the threshold defined by the China RoHS MCV Standard.

“X”表示该部件（于同类物品程度上）所含的危险和有毒物质超出中国RoHS MCV标准所定义的门槛值。

### **3.16 Corrosive environment**

Seagate electronic drive components pass accelerated corrosion testing equivalent to 10 years exposure to light industrial environments containing sulfurous gases, chlorine and nitric oxide, classes G and H per ASTM B845. However, this accelerated testing cannot duplicate every potential application environment.

Users should use caution exposing any electronic components to uncontrolled chemical pollutants and corrosive chemicals as electronic drive component reliability can be affected by the installation environment. The silver, copper, nickel and gold films used in Seagate products are especially sensitive to the presence of sulfide, chloride, and nitrate contaminants. Sulfur is found to be the most damaging. In addition, electronic components should never be exposed to condensing water on the surface of the printed circuit board assembly (PCBA) or exposed to an ambient relative humidity greater than 95%. Materials used in cabinet fabrication, such as vulcanized rubber, that can outgas corrosive compounds should be minimized or eliminated. The useful life of any electronic equipment may be extended by replacing materials near circuitry with sulfide-free alternatives.

## 4.0 Configuring and mounting the drive

---

This section contains the specifications and instructions for configuring and mounting the drive.

### 4.1 Handling and static-discharge precautions

After unpacking, and before installation, the drive may be exposed to potential handling and electrostatic discharge (ESD) hazards. Observe the following standard handling and static-discharge precautions:

**Caution:**

- Keep the drive in the electrostatic discharge (ESD) bag until you are ready for installation to limit the drive's exposure to ESD.
- Before handling the drive, put on a grounded wrist strap, or ground yourself frequently by touching the metal chassis of a computer that is plugged into a grounded outlet. Wear a grounded wrist strap throughout the entire installation procedure.
- Handle the drive only by its edges or frame.
- The drive is fragile—handle it with care. Do not press down on the drive top cover.
- Always rest the drive on a padded, antistatic surface until you mount it in the computer.
- Do not touch the connector pins or the printed circuit board.
- Do not remove the factory-installed labels from the drive or cover them with additional labels. Removal voids the warranty. Some factory-installed labels contain information needed to service the drive. Other labels are used to seal out dirt and contamination.

## 4.2 Configuring the drive

Each drive on the Serial ATA interface connects in a point-to-point configuration with the Serial ATA host adapter. There is no master/slave relationship because each drive is considered a master in a point-to-point relationships. If two drives are attached on one Serial ATA host adapter, the host operating system views the two devices as if they were both “masters” on two separate ports. This means both drives behave as if they are Device 0 (master) devices.

Serial ATA drives are designed for easy installation with no jumpers, terminators, or other settings. It is not necessary to set any jumpers on this drive for proper operation. The jumper block adjacent to the signal connector is for factory use only.

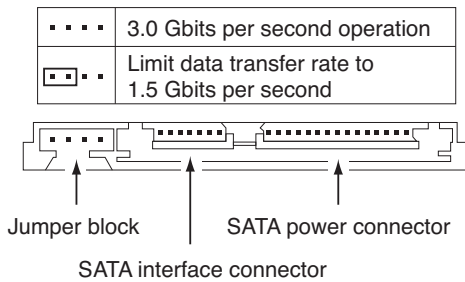

**Figure 2. Serial ATA connectors**

## 4.3 Serial ATA cables and connectors

The Serial ATA interface cable consists of four conductors in two differential pairs, plus three ground connections. The cable size may be 30 to 26 AWG with a maximum length of one meter (39.37 inches). See Table 7 for connector pin definitions. Either end of the SATA signal cable can be attached to the drive or host.

For direct backplane connection, the drive connectors are inserted directly into the host receptacle. The drive and the host receptacle incorporate features that enable the direct connection to be hot pluggable and blind mateable.

For installations which require cables, you can connect the drive as illustrated in Figure 3.

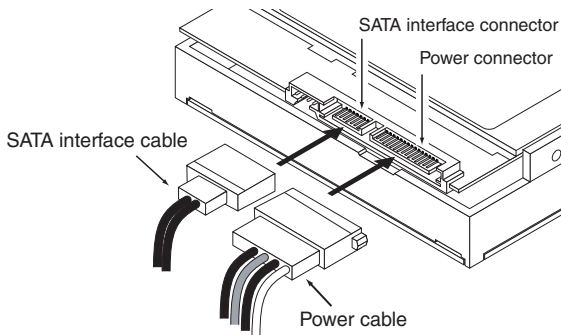

**Figure 3. Attaching SATA cabling**

Each cable is keyed to ensure correct orientation.

## 4.4 Drive mounting

You can mount the drive using four screws in the side-mounting holes or four screws in the bottom-mounting holes. See Figure 4 for drive mounting dimensions. Follow these important mounting precautions when mounting the drive:

- Allow a minimum clearance of 0.030 inches (0.76 mm) around the entire perimeter holes of the drive for cooling.
- Use only M3 UNC mounting screws.
- Do not overtighten the mounting screws (maximum torque: 4.0 inch-lb).
- Four (4) threads (0.080 inches) minimum screw engagement recommended.

Measurements shown in Figure 4 are in inches.

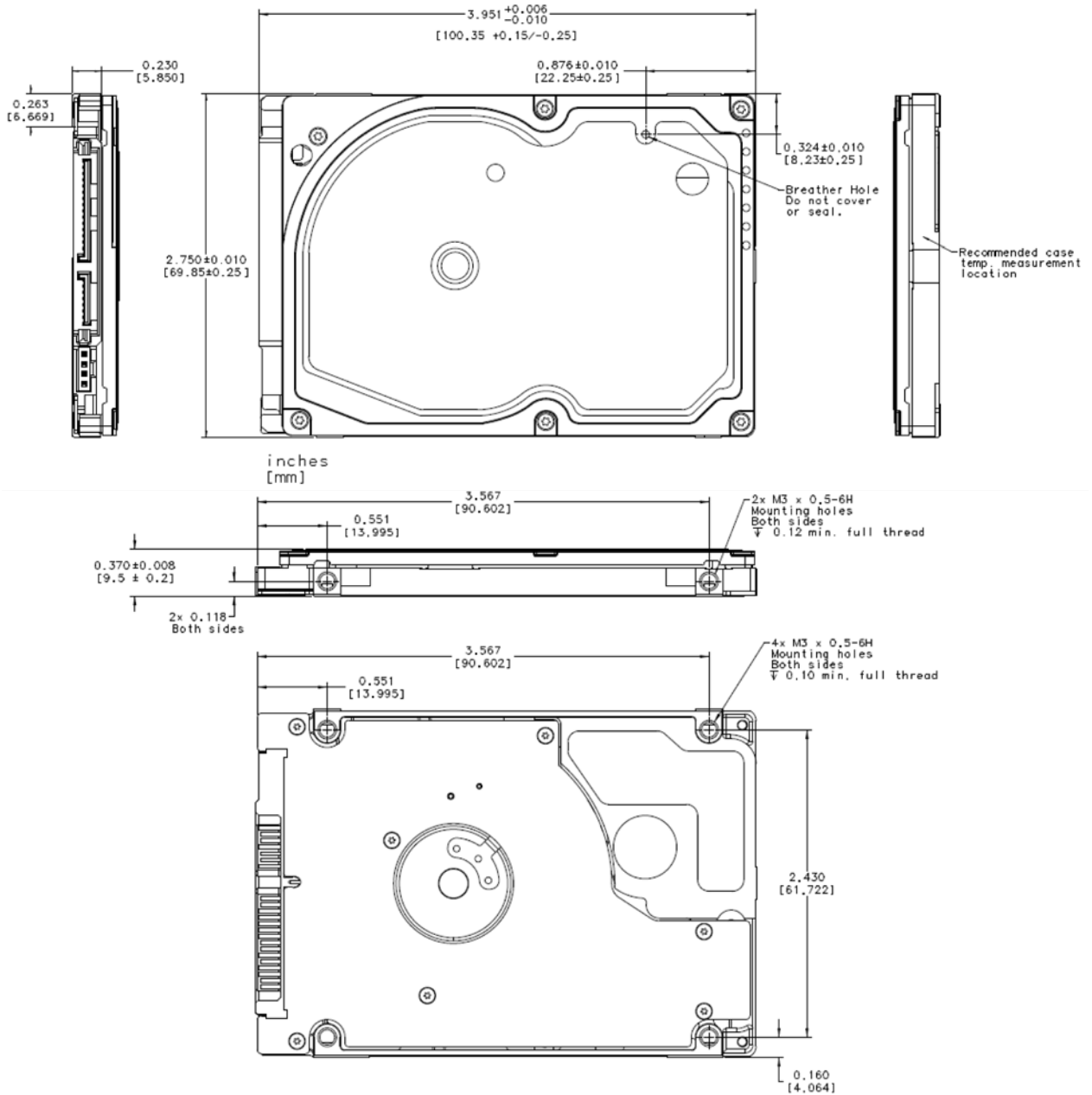

Figure 4. Mounting dimensions—top, side and end view

## **5.0 Serial ATA (SATA) interface**

---

These drives use the industry-standard Serial ATA interface that supports FIS data transfers. It supports ATA programmed input/output (PIO) modes 0–4; multiword DMA modes 0–2, and Ultra DMA modes 0–6. The drive also supports the use of the IORDY signal to provide reliable high-speed data transfers.

For detailed information about the Serial ATA interface, refer to the “Serial ATA: High Speed Serialized AT Attachment” specification.

### **5.1 Hot-Plug compatibility**

Momentum drives incorporate connectors which enable you to hot plug these drives in accordance with the Serial ATA: High Speed Serialized AT Attachment specification revision 2.0. This specification can be downloaded from <http://www.serialata.org>. This device requires a COMRESET from the host after a hotplug event.

## 5.2 Serial ATA device plug connector pin definitions

Table 7 summarizes the signals on the Serial ATA interface and power connectors.

**Table 7: Serial ATA connector pin definitions**

Segment	Pin	Function	Definition
<b>Signal</b>	S1	Ground	2nd mate
	S2	A+	Differential signal pair A from Phy
	S3	A-	
	S4	Ground	2nd mate
	S5	B-	Differential signal pair B from Phy
	S6	B+	
	S7	Ground	2nd mate

Key and spacing separate signal and power segments

<b>Power</b>	P1	V <sub>33</sub>	3.3V power
	P2	V <sub>33</sub>	3.3V power
	P3	V <sub>33</sub>	3.3V power, pre-charge, 2nd mate
	P4	Ground	1st mate
	P5	Ground	2nd mate
	P6	Ground	2nd mate
	P7	V <sub>5</sub>	5V power, pre-charge, 2nd mate
	P8	V <sub>5</sub>	5V power
	P9	V <sub>5</sub>	5V power
	P10	Ground	2nd mate
	P11	Reserved	The pin corresponding to P11 in the backplane receptacle connector is also reserved. The corresponding pin to be mated with P11 in the power cable receptacle connector shall always be grounded.
	P12	Ground	1st mate.
	P13	V <sub>12</sub>	12V power, pre-charge, 2nd mate
	P14	V <sub>12</sub>	12V power
	P15	V <sub>12</sub>	12V power

- All pins are in a single row, with a 1.27 mm (0.050") pitch.
- The comments on the mating sequence apply to the case of backplane blindmate connector only. In this case, the mating sequences are:
  - the ground pins P4 and P12.
  - the pre-charge power pins and the other ground pins.
  - the signal pins and the rest of the power pins.
- There are three power pins for each voltage. One pin from each voltage is used for pre-charge when installed in a blind-mate backplane configuration.
- All used voltage pins (V<sub>x</sub>) must be terminated.

### 5.3 Supported ATA commands

The following table lists Serial ATA standard commands that the drive supports. For a detailed description of the ATA commands, refer to the Serial ATA: High Speed Serialized AT Attachment specification. See “S.M.A.R.T. commands” on page 33 for details and subcommands used in the S.M.A.R.T. implementation.

Command name	Command code (in hex)	
<b>ATA-standard commands</b>		
Device Configuration Restore	B1h/C0h	
Device Configuration Freeze Lock	B1h/C1h	
Device Configuration Identify	B1h/C2h	
Device Configuration Set	B1h/C3h	
Download Microcode	92h	
Execute Device Diagnostics	90h	
Flush Cache	E7h	
Flush Cache Extended	EAh	
Identify Device	ECh	
Initialize Device Parameters	91h	
Read Buffer	E4h	
Read DMA	C8h	
Read DMA Extended	25h	
Read DMA without Retries	C9h	
Read Long with Retries	22h	
Read Long without Retries	23h	
Read Multiple	C4h	
Read Multiple Extended	29h	
Read Native Max Address	F8h	
Read Native Max Address Extended	27h	
Read Sectors	20h	
Read Sectors Extended	24h	
Read Sectors without Retries	21h	
Read Verify Sectors	40h	
Read Verify Sectors Extended	42h	
Read Verify Sectors without Retries	41h	
Seek	70h	
Set Features	EFh	
Set Max Address	F9h	
Note: Individual Set Max commands are identified by the value placed in the Set Max Features register as defined to the right.	Address:	00 <sub>H</sub>
	Password:	01 <sub>H</sub>
	Lock:	02 <sub>H</sub>
	Unlock:	03 <sub>H</sub>
	Freeze Lock:	04 <sub>H</sub>
Set Multiple Mode	C6h	
S.M.A.R.T. Disable Operations	B0h/D9h	



<b>Command name</b>	<b>Command code (in hex)</b>
S.M.A.R.T. Enable/Disable Autosave	B0h/D2h
S.M.A.R.T. Enable Operations	B0h/D8h
S.M.A.R.T. Enable/Disable Auto Offline	B0h/DBh
S.M.A.R.T. Enable One Attribute Modification	B0h/E0h
S.M.A.R.T. Execute Offline	B0h/D4h
S.M.A.R.T. Free Fall Protection Host Interface	FEh
S.M.A.R.T. Read Attribute Thresholds	B0h/D1h
S.M.A.R.T. Read Data	B0h/D0h
S.M.A.R.T. Read Log Sector	B0h/D5h
S.M.A.R.T. Return Status	B0h/DAh
S.M.A.R.T. Save Attribute Values	B0h/D3h
S.M.A.R.T. Write Attribute Thresholds	B0h/D7h
S.M.A.R.T. Write Attribute Values	B0h/E1h
S.M.A.R.T. Write Log Sector	B0h/D6h
Write Buffer	E8h
Write DMA	CAh
Write DMA Extended	35h
Write DMA without Retries	CBh
Write Long with Retries	32h
Write Long without Retries	33h
Write Multiple	C5h
Write Multiple Extended	39h
Write Sectors	30h, 31h
Write Sectors Extended	34h
<b>ATA-standard power-management commands</b>	
Check Power Mode	E5h
Idle	E3h
Idle Immediate	E1h
Sleep	E6h
Standby	E2h
Standby Immediate	E0h
<b>ATA-standard security commands</b>	
Security Set Password	F1h
Security Unlock	F2h
Security Erase Prepare	F3h
Security Erase Unit	F4h
Security Freeze Lock	F5h
Security Disable Password	F6h

### 5.3.1 Identify Device command

The Identify Device command (command code EC<sub>H</sub>) transfers information about the drive to the host following power up. The data is organized as a single 512-byte block of data, whose contents are shown in the table on page 27. All reserved bits or words should be set to zero. Parameters listed with an “x” are drive-specific or vary with the state of the drive. See Section 3.0 on page 4 for default parameter settings.

The following commands contain drive-specific features that may not be included in the Serial ATA specification.

Word	Description	Value
0	Configuration information: <ul style="list-style-type: none"> <li>• Bit 15: 0 = ATA; 1 = ATAPI</li> <li>• Bit 7: removable media</li> <li>• Bit 6: removable controller</li> <li>• Bit 0: reserved</li> </ul>	0C5A <sub>H</sub>
1	Number of logical cylinders	16,383
2	ATA-reserved	0000 <sub>H</sub>
3	Number of logical heads	16
4	Retired	0000 <sub>H</sub>
5	Retired	0000 <sub>H</sub>
6	Number of logical sectors per logical track: 63	003F <sub>H</sub>
7–9	Retired	0000 <sub>H</sub>
10–19	Serial number: (20 ASCII characters, 0000 <sub>H</sub> = none)	ASCII
20	Retired	0000 <sub>H</sub>
21	Retired	0400 <sub>H</sub>
22	Obsolete	0000 <sub>H</sub>
23–26	Firmware revision (8 ASCII character string, padded with blanks to end of string)	x.xx
27–46	Drive model number: (40 ASCII characters, padded with blanks to end of string)	ST9750422AS ST9750420AS ST9750420ASG ST9500424AS ST9500423AS ST9500423ASG
47	(Bits 7–0) Maximum sectors per interrupt on Read multiple and Write multiple (16)	8010 <sub>H</sub>
48	Reserved	0000 <sub>H</sub>
49	Standard Standby timer, IORDY supported and may be disabled	2F00 <sub>H</sub>
50	ATA-reserved	0000 <sub>H</sub>
51	PIO data-transfer cycle timing mode	0200 <sub>H</sub>
52	Retired	0200 <sub>H</sub>
53	Words 54–58, 64–70 and 88 are valid	0007 <sub>H</sub>
54	Number of current logical cylinders	xxxx <sub>H</sub>
55	Number of current logical heads	xxxx <sub>H</sub>

Word	Description	Value
56	Number of current logical sectors per logical track	xxxx <sub>H</sub>
57–58	Current capacity in sectors	xxxx <sub>H</sub>
59	Number of sectors transferred during a Read Multiple or Write Multiple command	xxxx <sub>H</sub>
60–61	Total number of user-addressable sectors This field contains a value that is one greater than the total number of user-addressable sectors. The maximum value that shall be placed in this field is 0FFFFFFFh. The 0FFFFFFFh value applies to all capacities over 137Gbytes (see Section 3.2 and 3.3 for related information).	ST9750422AS = 0FFFFFFFh ST9750420AS = 0FFFFFFFh ST9750420ASG = 0FFFFFFFh ST9500424AS = 0FFFFFFFh ST9500423AS = 0FFFFFFFh ST9500423ASG = 0FFFFFFFh
62	Retired	0000 <sub>H</sub>
63	Multiword DMA active and modes supported (see note following this table)	xx07 <sub>H</sub>
64	Advanced PIO modes supported (modes 3 and 4 supported)	0003 <sub>H</sub>
65	Minimum multiword DMA transfer cycle time per word (120 ns)	0078 <sub>H</sub>
66	Recommended multiword DMA transfer cycle time per word (120 ns)	0078 <sub>H</sub>
67	Minimum PIO cycle time without IORDY flow control (240 ns)	00F0 <sub>H</sub>
68	Minimum PIO cycle time with IORDY flow control (120 nsec)	0078 <sub>H</sub>
69–74	ATA-reserved	0000 <sub>H</sub>
75	Queue depth	0000 <sub>H</sub>
76	Serial ATA capabilities	0508 <sub>H</sub>
77	ATA-reserved	0000 <sub>H</sub>
78	Serial ATA features supported	0048 <sub>H</sub>
79	Serial ATA features enabled	0040 <sub>H</sub>
80	Major version number	003E <sub>H</sub>
81	Minor version number	0000 <sub>H</sub>
82	Command sets supported	306B <sub>H</sub>
83	Command sets supported	4001 <sub>H</sub>
84	Command sets support extension	4000 <sub>H</sub>
85	Command sets enabled	30xx <sub>H</sub>
86	Command sets enabled	0001 <sub>H</sub>
87	Command sets enable extension	4000 <sub>H</sub>
88	Ultra DMA support and current mode (see note following this table)	xx7F <sub>H</sub>
89	Security erase time	0000 <sub>H</sub>
90	Enhanced security erase time	0000 <sub>H</sub>
92	Master password revision code	FFFE <sub>H</sub>
93	Hardware reset value (see description following this table)	xxxx <sub>H</sub>

Word	Description	Value
94	Auto acoustic management setting	xxxx <sub>H</sub>
95–99	ATA-reserved	0000 <sub>H</sub>
100–103	Total number of user-addressable LBA sectors available (see Section 3.2 for related information) These words are required for drives that support the 48-bit addressing feature. Maximum value: 0000FFFFFFFF <sub>H</sub> .	ST9750422AS = 1,465,149,168 ST9750420AS = 1,465,149,168 ST9750420ASG = 1,465,149,168 ST9500424AS = 976,773,168 ST9500423AS = 976,773,168 ST9500423ASG = 976,773,168
104–118	ATA-reserved	0000 <sub>H</sub>
119	Free Fall Protection support (bit 5)	1 = Free Fall Protection supported 0 = Free Fall Protection not supported
120	Free Fall Protection enable/disable (bit 5)	1 = Free Fall Protection feature is enabled 0 = Free Fall Protection feature is disabled
121–127	ATA-reserved	0000 <sub>H</sub>
128	Security status	0001 <sub>H</sub>
129–159	Seagate-reserved	xxxx <sub>H</sub>
160–254	ATA-reserved	0000 <sub>H</sub>
255	Integrity word	xxA5 <sub>H</sub>

**Note.** See the bit descriptions below for words 63, 88, 93 and 94 of the Identify Drive data:

**Description (if bit is set to 1)**

Bit	Word 63
0	Multiword DMA mode 0 is supported.
1	Multiword DMA mode 1 is supported.
2	Multiword DMA mode 2 is supported.
8	Multiword DMA mode 0 is currently active.
9	Multiword DMA mode 1 is currently active.
10	Multiword DMA mode 2 is currently active.

<b>Bit</b>	<b>Word 88</b>
0	Ultra DMA mode 0 is supported.
1	Ultra DMA mode 1 is supported.
2	Ultra DMA mode 2 is supported.
3	Ultra DMA mode 3 is supported.
4	Ultra DMA mode 4 is supported.
5	Ultra DMA mode 5 is supported
6	Ultra DMA mode 6 is supported
8	Ultra DMA mode 0 is currently active.
9	Ultra DMA mode 1 is currently active.
10	Ultra DMA mode 2 is currently active.
11	Ultra DMA mode 3 is currently active.
12	Ultra DMA mode 4 is currently active.
13	Ultra DMA mode 5 is currently active.
14	Ultra DMA mode 6 is currently active.
<b>Bit</b>	<b>Word 93</b>
13	1 = 80-conductor cable detected, CBLID above V <sub>IH</sub> 0 = 40-conductor cable detected, CBLID below V <sub>IL</sub>

### 5.3.2 Set Features command

This command controls the implementation of various features that the drive supports. When the drive receives this command, it sets BSY, checks the contents of the Features register, clears BSY and generates an interrupt. If the value in the register does not represent a feature that the drive supports, the command is aborted. Power-on default has the read look-ahead and write caching features enabled. The acceptable values for the Features register are defined as follows:

**Table 8: Set Features command values**

02 <sub>H</sub>	Enable write cache ( <i>default</i> ).
03 <sub>H</sub>	Set transfer mode (based on value in Sector Count register). Sector Count register values:
00 <sub>H</sub>	Set PIO mode to default (PIO mode 2).
01 <sub>H</sub>	Set PIO mode to default and disable IORDY (PIO mode 2).
08 <sub>H</sub>	PIO mode 0
09 <sub>H</sub>	PIO mode 1
0A <sub>H</sub>	PIO mode 2
0B <sub>H</sub>	PIO mode 3
0C <sub>H</sub>	PIO mode 4 ( <i>default</i> )
20 <sub>H</sub>	Multiword DMA mode 0
21 <sub>H</sub>	Multiword DMA mode 1
22 <sub>H</sub>	Multiword DMA mode 2
40 <sub>H</sub>	Ultra DMA mode 0
41 <sub>H</sub>	Ultra DMA mode 1
42 <sub>H</sub>	Ultra DMA mode 2
43 <sub>H</sub>	Ultra DMA mode 3
44 <sub>H</sub>	Ultra DMA mode 4
45 <sub>H</sub>	Ultra DMA mode 5
46 <sub>H</sub>	Ultra DMA mode 6
55 <sub>H</sub>	Disable read look-ahead (read cache) feature.
82 <sub>H</sub>	Disable write cache
AA <sub>H</sub>	Enable read look-ahead (read cache) feature ( <i>default</i> ).
F1 <sub>H</sub>	Report full capacity available

**Note.** At power-on, or after a hardware or software reset, the default values of the features are as indicated above.

### 5.3.3 S.M.A.R.T. commands

S.M.A.R.T. provides near-term failure prediction for disc drives. When S.M.A.R.T. is enabled, the drive monitors predetermined drive attributes that are susceptible to degradation over time. If self-monitoring determines that a failure is likely, S.M.A.R.T. makes a status report available to the host. Not all failures are predictable. S.M.A.R.T. predictability is limited to the attributes the drive can monitor. For more information on S.M.A.R.T. commands and implementation, see the *Draft ATA-8 Standard*.

SeaTools diagnostic software activates a built-in drive self-test (DST S.M.A.R.T. command for D4<sub>H</sub>) that eliminates unnecessary drive returns. The diagnostic software ships with all new drives and is also available at: <http://seatools.seagate.com>.

This drive is shipped with S.M.A.R.T. features disabled. You must have a recent BIOS or software package that supports S.M.A.R.T. to enable this feature. The table below shows the S.M.A.R.T. command codes that the drive uses.

**Table 9: S.M.A.R.T. commands**

Code in features register	S.M.A.R.T. command
D0 <sub>H</sub>	S.M.A.R.T. Read Data
D1 <sub>H</sub>	Vendor-specific
D2 <sub>H</sub>	S.M.A.R.T. Enable/Disable Attribute Autosave
D3 <sub>H</sub>	S.M.A.R.T. Save Attribute Values
D4 <sub>H</sub>	S.M.A.R.T. Execute Off-line Immediate (runs DST)
D5 <sub>H</sub>	S.M.A.R.T. Read Log Sector
D6 <sub>H</sub>	S.M.A.R.T. Write Log Sector
D7 <sub>H</sub>	Vendor-specific
D8 <sub>H</sub>	S.M.A.R.T. Enable Operations
D9 <sub>H</sub>	S.M.A.R.T. Disable Operations
DA <sub>H</sub>	S.M.A.R.T. Return Status

**Note.** If an appropriate code is not written to the Features Register, the command is aborted and 0x04 (abort) is written to the Error register.





# Index

## A

- ACA 17
- acoustics 6, 15
- Active mode 13
- Address 26
- AFR 16
- Agency certification 17
- Altitude 14
- Altitude, nonoperating 5
- Altitude, operating 5
- Ambient temperature 5, 14
- ambient temperature 9
- Annualized Failure Rate 16
- Annualized Failure Rate (AFR) 6
- Areal density 5, 8
- ATA commands 26
- ATA data-transfer modes supported 5
- Australia/New Zealand Standard AS/NZS3548 1995 17
- Australian Communication Authority (ACA) 17
- Australian C-Tick 17
- Average seek time 9
- Average seek, read 5

## B

- bels 6
- BPI 5
- buffer 5, 8
- Bytes per sector 5, 7

## C

- cables and connectors 22
- Cache 5
- cache 8
- capacity 7
- case temperature 14
- CE mark 17
- certification 17
- Check Power Mode 27
- chemical substances 19
- China RoHS directive 19
- Class B computing device 18
- compatibility 17
- Conducted noise 12
- Conducted RF immunity 16
- Configuring the drive 21
- connectors 22
- CSA C22.2 (950) 17
- current 5
- cycles 16
- Cylinders 7

## D

- data-transfer rates 2
- DC power 10
- Default logical geometry 7
- density 5
- Device Configuration Freeze Lock 26
- Device Configuration Restore 26
- Device Configuration Set 26
- Diagnostics 26
- dimensions 23
- Discs 5
- dissipation 10
- Download Microcode 26

## E

- Electrical fast transient 16
- Electromagnetic compatibility 17
- Electromagnetic Compatibility Directive (89/336/EEC) 17
- Electromagnetic immunity 16
- Electrostatic discharge 16
- electrostatic discharge (ESD) 21
- EN 55022, Class B 17
- EN 55024 17
- EN 60950 17
- Environmental protection 19
- Environmental specifications 14
- error-correction algorithms 2
- errors 6, 16
- ESD 21
- EU 17
- European Union (EU) requirements 17
- European Union Restriction of Hazardous Substances 19
- evice Configuration Identify 26
- Execute Device Diagnostics 26

## F

- FCC verification 18
- features 2
- Federal Communications Commission 18
- Flush Cache 26
- Flush Cache Extended 26
- Formatted capacity 7
- Formatted Gbytes 5
- Free Fall Protection feature 17
- Freeze Lock 26

## G

- Gbytes 7
- geometry 7
- gradient 5
- Guaranteed sectors 5, 7

guaranteed sectors 7

## H

handling 21  
Handling precautions 21  
heads 7  
Height 5  
height 8  
humidity 5

## I

I/O data-transfer rate 5, 8  
Identify 26  
Identify Device 26  
Identify Device command 28  
Idle 10, 27  
Idle and Standby timers 13  
Idle Immediate 27  
Idle mode 5, 13  
Idle mode power 10  
IEC950 17  
Information Technology Equipment (ITE) 17  
Initialize Device Parameters 26  
Input noise ripple 12  
Interface 8  
interface 24  
Interleave 8  
Internal data transfer rate 5  
Internal data-transfer rate 8  
ITE 17

## K

Korean RRL 17

## L

latency 5  
LBA mode 7  
Length 5  
length 8  
Load/Unload 16  
logical geometry 7

## M

master/slave 3  
Max Address 26  
maximum temperature 14  
Microcode 26  
mounting 23  
mounting screws 14  
mounting the drive 21

## N

noise 12  
nominal power 9  
Nonoperating shock 15  
Nonoperating vibration 15  
Nonrecoverable read errors 6  
nonrecoverable read errors 16

## O

Operating shock 14  
Operating vibration 15

## P

Physical characteristics 8  
Physical organization 7  
Physical read/write heads 5  
point-to-point 3, 22  
Power consumption 10  
power dissipation 10  
power management 13  
power on/off cycles 16  
Power specifications 10  
Power-management modes 13  
Power-on to Ready 9  
Power-on to ready 5  
precautions 21, 23  
programmable power management 13

## Q

quick reference 4

## R

Radiated RF immunity 16  
Radio and television interference 18  
radio frequency (RF) 16  
random track location 10  
Read Buffer 26  
Read DMA 26  
Read DMA Extended 26  
Read DMA without Retries 26  
read errors 6, 16  
Read Long with Retries 26  
Read Long without Retries 26  
Read Multiple 26  
Read Multiple Extended 26  
Read Native Max Address 26  
Read Native Max Address Extended 26  
Read Sectors 26  
Read Sectors Extended 26  
Read Sectors without Retries 26  
Read Verify Sectors 26  
Read Verify Sectors Extended 26  
Read Verify Sectors without Retries 26

- Read/write heads 7
- Read/write power 5
- read/write power and current 10
- Recording density 5, 8
- Recording method 8
- Recording technology 8
- Relative humidity 5, 14
- Reliability 16
- resistance 12
- Retries 26
- RF 16
- RoHS 19
- RPM 5
- RRL 17

## S

- S.M.A.R.T. 27
- S.M.A.R.T. implementation 26
- Safety certification 17
- SATA 8, 24
- screws 14, 23
- sector 7
- sectors 7
- Sectors per track 7
- Security Disable Password 27
- Security Erase Prepare 27
- Security Erase Unit 27
- Security Freeze Lock 27
- Security Set Password 27
- Security Unlock 27
- Seek 26
- seek mode 10
- Seek power 5
- Seek time 9
- seek time 5
- Seeking 10
- Self refresh, low power 13
- Serial ATA 8
- Serial ATA (SATA) interface 24
- serial ATA ports 3
- servo electronics 10
- Set Features 26
- Set Max Address 26
- Set Multiple Mode 26
- Shock 14
- Shock, nonoperating 6
- Shock, operating 5, 6
- single-track seeks 9
- Sleep 10, 27
- Sleep mode 5, 13
- sound power 6
- Specification summary table 4
- Spindle speed 5, 8
- Spinup 10
- spinup power 10

- Standby 10, 27
- Standby Immediate 27
- Standby mode 5, 10, 13
- Standby to Ready 9
- Standby to ready 5
- Start/stop times 9
- Startup current 5
- static-discharge 21
- support services 1
- Surge immunity 16

## T

- technical support services 1
- temperature 5, 9, 14
- Temperature gradient 5, 14
- timers 13
- TPI 5
- Track density 5, 8
- Track-to-track seek time 5, 9
- TUV North America 17

## U

- UL 1950 17

## V

- Vibration 15
- Vibration, nonoperating 6
- Vibration, operating 6
- Voltage dips, interrupts 16
- Voltage tolerance 5, 12

## W

- Warranty 16
- Weight 5
- weight 8
- Wet bulb temperature 5, 14
- Width 5
- width 8
- Write Buffer 27
- Write DMA 27
- Write DMA Extended 27
- Write Long with Retries 27
- Write Long without Retries 27
- Write Multiple 27
- Write Sectors 27







**Seagate Technology LLC**  
**920 Disc Drive, Scotts Valley, California 95066-4544, USA**  
*Publication Number: 100610629, Rev. B*