



Seagate® Nytro® XF1230 SATA SSD

Product Manual

XF1230-1A0240
XF1230-1A0480
XF1230-1A0960
XF1230-1A1920



100797573, Rev. E
October 2016

Revision History

Version and Date	Description of Changes
Rev E, October 2016	Updated SMART attributes in Section 6.2, SMART Attributes .
Rev D, August, 2016	First public release of the document.

© 2016, Seagate Technology LLC All rights reserved. Publication number: 100797573, Rev. E, October 2016

Seagate Technology reserves the right to make changes to the product(s) or information disclosed herein at any time without notice.

Seagate, Seagate Technology and the Spiral logo are registered trademarks of Seagate Technology LLC in the United States and/or other countries. Nytro, Nytro WarpDrive and SeaTools are either trademarks or registered trademarks of Seagate Technology LLC or one of its affiliated companies in the United States and/or other countries. All other trademarks or registered trademarks are the property of their respective owners.

No part of this publication may be reproduced in any form without written permission of Seagate Technology LLC. Call 877-PUB-TEK1(877-782-8351) to request permission.

When referring to drive capacity, one gigabyte, or GB, equals one billion bytes and one terabyte, or TB, equals one trillion bytes. Your computer's operating system may use a different standard of measurement and report a lower capacity. In addition, some of the listed capacity is used for formatting and other functions, and thus will not be available for data storage. Actual quantities will vary based on various factors, including file size, file format, features and application software. Actual data rates may vary depending on operating environment and other factors. The export or re-export of hardware or software containing encryption may be regulated by the U.S. Department of Commerce, Bureau of Industry and Security (for more information, visit www.bis.doc.gov), and controlled for import and use outside of the U.S. Seagate reserves the right to change, without notice, product offerings or specifications.

Contents

Seagate Technology Support Services	4
1. Introduction	5
2. Specifications	7
2.1 Models and Capacity	7
2.2 Performance	7
2.3 Power	8
2.3.1 Power Consumption	8
2.4 Reliability	9
2.5 Endurance	9
3. Mechanical Information	10
3.1 Dimensions and Weight	10
4. Pin and Signal Descriptions	11
4.1 Serial ATA Interface Connector	11
4.2 Pin Locations	12
4.3 Connector Pin Signal Definitions	12
4.4 Power Pin Signal Definitions	13
4.5 SSD Activity LED Indicator (Optional)	13
5. Supported ATA Command List	15
5.1 ATA Feature Set	15
5.2 ATA Command Description	15
5.3 Security	16
5.3.1 Password Loss	16
6. SMART Support	17
6.1 SMART Command Set	17
6.2 SMART Attributes	18
6.3 SMART Trip	19
7. Safety, Standards, and Compliance	20
7.1 Safety Characteristics	20
7.2 Electromagnetic Compliance and Standards	20
7.3 Standards	20
7.4 Electromagnetic Compatibility	20
7.5 Electromagnetic Compliance	21
7.6 Electromagnetic Compliance for the European Union	21
7.7 Australian RCM	21
7.8 Korean KCC	21
7.9 Taiwanese BSMI	21
7.10 China Requirements — China RoHS 2	22
7.11 Japan VCCI	23
7.12 Reference Documents	23

Seagate Technology Support Services

For Nytro® Support, visit: <http://www.seagate.com/support/by-product/ssd-and-pcie-flash/>

For information regarding online support and services, visit: <http://www.seagate.com/contacts/>

Available services include:

- Presales & Technical support
- Global Support Services telephone numbers & business hours
- Authorized Service Centers

For information regarding Warranty Support, visit: <http://www.seagate.com/support/warranty-and-replacements/>

For information regarding data recovery services, visit:

<http://www.seagate.com/services-software/seagate-recovery-services/recover/>

For Seagate OEM and Distribution partner and Seagate reseller portal, visit: <http://www.seagate.com/partners>

1. Introduction

The Seagate® Nytro® XF1230 SSDs provide high reliability and sustained performance for enterprise Server and Storage products. The Nytro XF1230 series offers SATA interface, fully compatible with SATA 3.1 6.0Gb/s.

Table 1 Nytro XF1230 Card Features

Feature	Description	
Capacity	<ul style="list-style-type: none"> 240, 480, 960, 1920 GB 	
Certifications, Eco-Compliance	<ul style="list-style-type: none"> CE, UL, FCC, RCM, BSMI, KCC, Microsoft WHQL, SATA-IO RoHS 	
Dimension	<ul style="list-style-type: none"> (69.85±0.25) x (100±0.25) x (Max. 7) mm 	SSD Outer case can support suitable Z-height for various host situations.
Endurance	<ul style="list-style-type: none"> Endurance varies with product capacity. See Table 10, Endurance, on page 9. 	
Form	<ul style="list-style-type: none"> 2.5 Inch Standard SSD 	
Interface Compliance	<ul style="list-style-type: none"> Fully compliant with SATA revision 3.1, compatible with SATA 6.0Gb/s interface rates. Fully compliant with ATA-8/ACS-3 Standard. PIO, DMA, UDMA (up to 6, dependent on host) supported. SATA 6.0Gb/s Native Command Queuing (NCQ): up to 32 commands. SMART command transport (SCT) technology. Data Set Management Command Trim support. 	
Latency	<ul style="list-style-type: none"> Read: 140 µs (Typ.) Write: 60 µs (Typ.) 	Latency measured with transfer size 4 KB and queue depth of 1 on a random workload, and based on high density (1920 GB).
NAND	<ul style="list-style-type: none"> 16 nm 	
Performance Random (Sustained)	<ul style="list-style-type: none"> 4 KB Read: Up to 98K IOPS 4 KB Write: Up to 16.8K IOPS 8 KB Read: Up to 58K IOPS 8 KB Write: Up to 8K IOPS 	<p>Actual performance may vary depending on use conditions and environment.</p> <p>See Section 2.2, Performance, on page 7.</p> <p>Typical I/O performance numbers measured with a queue depth of 32, write cache enabled, 6Gb/s SAS chipset port, and the Intel RST driver.</p>
Performance Sequential (128 KB Sustained)	<ul style="list-style-type: none"> Read: Up to 560MB/s Write: Up to 505MB/s 	<p>Actual performance may vary depending on use conditions and environment.</p> <p>See Section 2.2, Performance, on page 7.</p> <p>Typical I/O performance numbers as measured with a queue depth of 32, write cache enabled, 6Gb/s SAS chipset port, and the Intel RST driver.</p>
Power Consumption	<ul style="list-style-type: none"> Active: Up to 5.7 W Idle: Up to 1.0 W 	<p>See Section 2.3, Power, on page 8.</p> <p>RMS Average.</p> <p>NOTE This specification is for the 1920 GB drive; smaller capacity drives have lower active power.</p>
Power Loss Protection		
Power Management	<ul style="list-style-type: none"> 2.5 inch: 5 V SATA Supply OS-aware hot plug/removal 	
Power On Ready	<ul style="list-style-type: none"> Normal shut down: 5 s Unsolicited shut down: 21 s 	Based on High Density (1920 GB).

Table 1 Nytro XF1230 Card Features (continued)

Feature	Description	
Quality of Service	<ul style="list-style-type: none"> ■ Read/Write: 0.2 ms/0.9 ms (99.9%) 	Based on Random 4 KB, queue depth=1, and 1920 GB Density.
Reliability	<ul style="list-style-type: none"> ■ MTBF: 2 million hours ■ BER: 1 error in 10¹⁷bits read ■ End-to-End data-path protection 	
Shock	<ul style="list-style-type: none"> ■ Operating: 1500G, duration 0.5ms ■ Non-Operating: 1500G, duration 0.5ms 	
Temperature Range (Operating)	<ul style="list-style-type: none"> ■ 0°C to 70°C ■ Temperature Sensor (SMART Attribute ID 194) 	
Vibration	<ul style="list-style-type: none"> ■ Operating:20G, 10~2 KHz ■ Non-Operating: 20G, 10~2 KHz 	
Voltage	<ul style="list-style-type: none"> ■ 5V±5% 	
Warranty	<ul style="list-style-type: none"> ■ Five years limited Warranty with Media Usage, based on the shorter of term or endurance usage of the drive. 	
Weight	<ul style="list-style-type: none"> ■ up to 85g ±5% 	

2. Specifications

2.1 Models and Capacity

Table 2 Nytro XF1230 Card Models

Device Name	Model Names	Usable Capacity	LBAs
Nytro XF1230	XF1230-1A0240	240 GB	468,862,128
Nytro XF1230	XF1230-1A0480	480 GB	937,703,088
Nytro XF1230	XF1230-1A0960	960 GB	1,875,385,008
Nytro XF1230	XF1230-1A1920	1920 GB	3,750,748,848

2.2 Performance

Table 3 Random Read/Write Input/Output Operations Per Second (IOPS)

Parameter	240 GB	480 GB	960 GB	1920 GB
Random 4 KB Read (IOPS)	96,700	98,000	98,000	98,000
Random 4 KB Write (IOPS)	8,700	15,800	16,800	16,000
Random 8 KB Read (IOPS)	58,000	58,000	58,000	58,000
Random 8 KB Write (IOPS)	4,000	8,000	8,000	8,000

Table 4 Sequential Read/Write Throughput

Parameter	240 GB	480 GB	960 GB	1920 GB
Sequential Read (Sustained)	560MB/s	560MB/s	560MB/s	560MB/s
Sequential Write (Sustained)	306MB/s	505MB/s	490MB/s	445MB/s

NOTE

Information on performance:

- Performance measured with queue depth set to 32.
- 4 KB = 4,096 bytes, 8 KB = 8,192 bytes.
- Drive write cache enabled.
- Measurements performed on Full Logical Block Address (LBA) range, sustained for 2x Drive Capacity.
- Set to 4 KB alignment.
- Performance test precondition: Drive is preconditioned with 2x drive capacity 128 KB write IOs.
- Measured on system with Intel Xeon E5-2640v3 and C610 chipset with on-board AHCI controller running Microsoft Windows® 2012 R2 DC. System variations may affect measured results.
- MB/s = 1,000,000 bytes/second.

2.3 Power

The 2.5" drive uses 5 V DC power.

Table 5 Operating Voltage

	240 GB	480 GB	960 GB	1920 GB
Operating Voltage range	5 V ± 5%	5 V ± 5%	5 V ± 5%	5 V ± 5%
Inrush Current	0.91 A	1.10 A	1.20 A	1.60 A

2.3.1 Power Consumption

Table 6 Power Consumption

	240 GB	480 GB	960 GB	1920 GB
Active Read – Average	2.1 W	2.2 W	2.2 W	2.8 W
Active Write – Average	2.8 W	4.2 W	4.2 W	4.3 W
Active Read – Burst 500 μS Average	2.2 W	2.4 W	2.4 W	3.0 W
Active Write – Burst 500 μS Average	3.2 W	4.8 W	6.1 W	5.7 W
Idle	0.8 W	0.8 W	0.8 W	0.9 W

Table 7 Temperature, Humidity, Shock

Specification	Nytro XF1230
Temperature	
Operating (case temperature at specific airflow)	0°C to 70°C
Non-Operating	- 40°C to 95°C
Humidity	
Operating and Non-Operating	5 to 95%
Shock	
Operating and Non-Operating	1500 G at 0.5 ms

NOTE

Operating, as measured by temperature sensor, SMART Attribute ID 194.

- Measured without condensation.
- The Shock specification assumes that the SSD is mounted securely with the input vibration applied to the drive mounting. Stimulus may be applied in the X, Y or Z axis.
- Operating Shock: The drive, as installed for normal operation, operates error-free while subjected to intermittent shock not exceeding specification. Shock may be applied in the X, Y, or Z-axis. Shock must not be repeated more than once every 2 seconds.

- **Non-Operating Shock:** The limits of non-operating shock applies to all conditions of handling and transportation. This includes isolated and integrated drives. Shock may be applied in the X, Y, or Z-axis.

Table 8 Vibration

Specification	Nytro XF1230
Maximum Vibrations	
Operating	20 G (10 to 2000 KHz)
Non-Operating	20 G (10 to 2000 KHz)

NOTE

The Vibration specification assumes that the SSD is mounted securely with the input Vibration applied to the drive mounting screws. Stimulus may be applied in the X, Y or Z axis.

- **Operating Vibration:** The drive, as installed for normal operation, shall operate error free while subjected to specified vibration not exceeding specification. Vibration may be applied in the X, Y, or Z-axis.
- **Non-Operating Vibration:** The limits of non-operating vibration shall apply to all conditions of handling and transportation. This includes both isolated drive and integrated drives. Vibration may be applied in the X, Y, or Z-axis.

2.4 Reliability

Table 9 Reliability

Specification	Nytro XF1230
Mean time between failures (MTBF)	2 million hours
Uncorrectable Bit Error Rate	<1 error in 10^{17} bits read

2.5 Endurance

Table 10 Endurance

Specification	240 GB	480 GB	960 GB	1920 GB
Endurance Rating	0.5 DWPD	0.6 DWPD	0.67 DWPD	0.67 DWPD

NOTE

Information on endurance:

- SSD Endurance is lifetime on finite amount of writes.
- DWPD is drive write per day.
- Limited Warranty with Media Usage provides coverage for the warranty period or the endurance usage of the drive.

3. Mechanical Information

3.1 Dimensions and Weight

Weight: 0.187 lbs, 85 g

Height: Maximum 7 mm

Width: 69.85±0.25

Length: 100±0.25

NOTE All dimensions are in millimeters.

Figure 1 Nytro XF1230 Dimensions

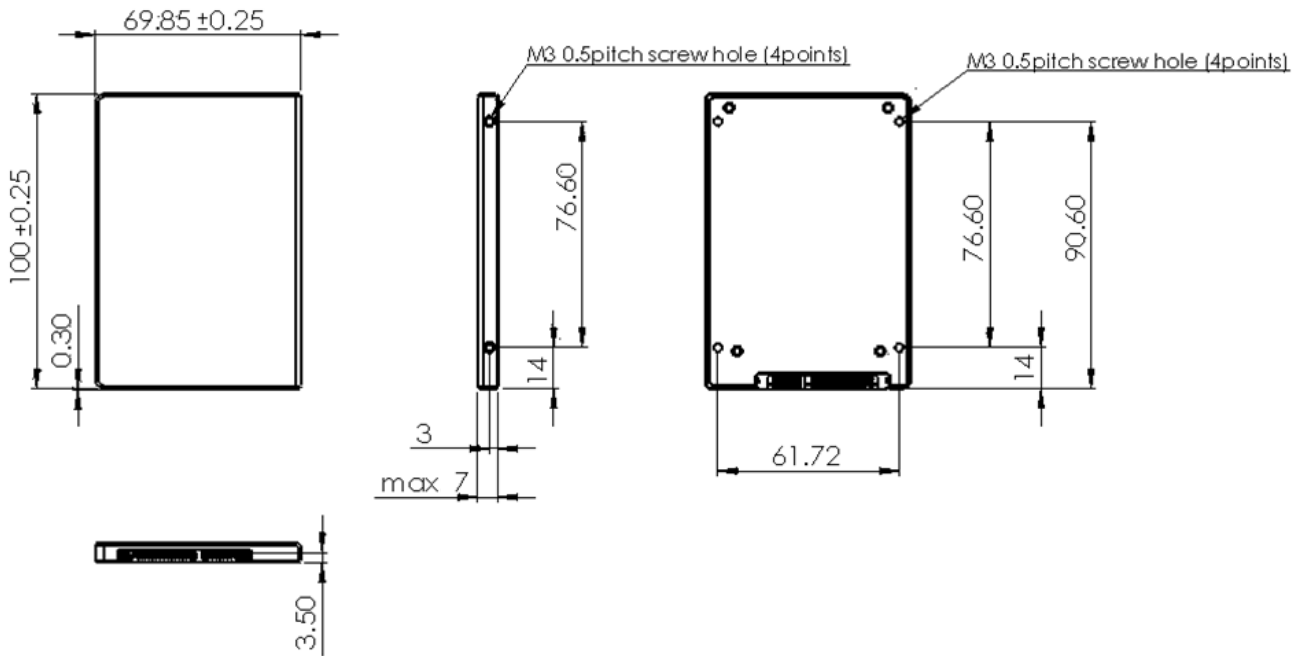

4. Pin and Signal Descriptions

4.1 Serial ATA Interface Connector

Figure 2 Connector Physical Dimension and Connector Assembly

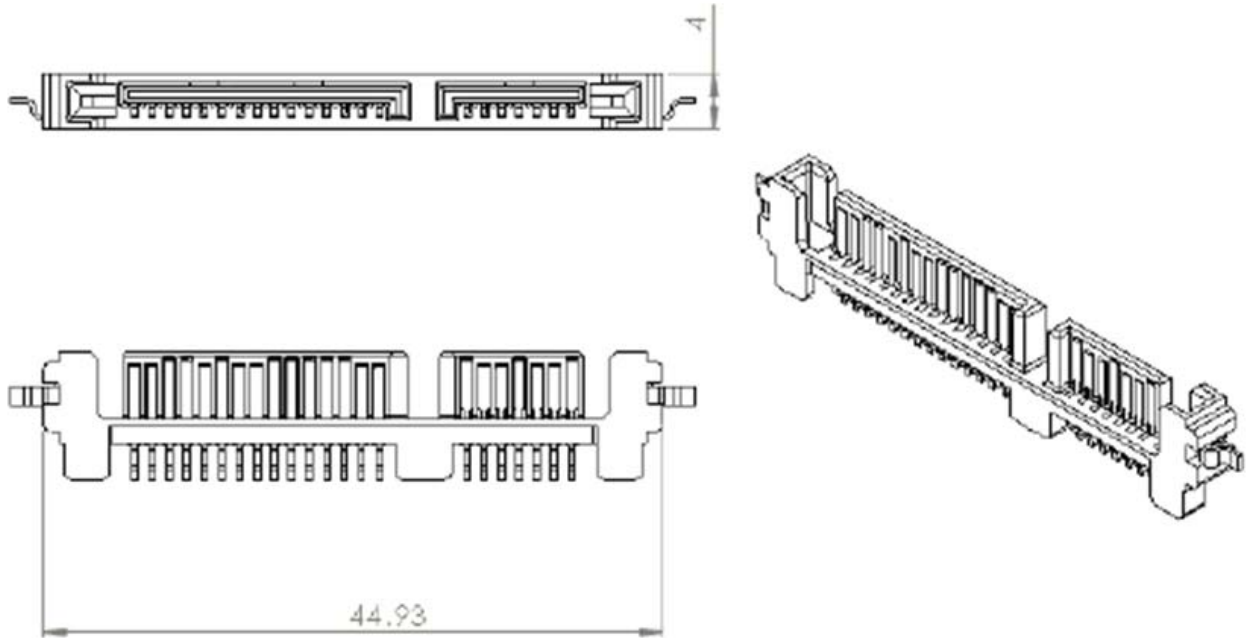

4.2 Pin Locations

Figure 3 Layout of 2.5-inch Signal and Power Segment Pins

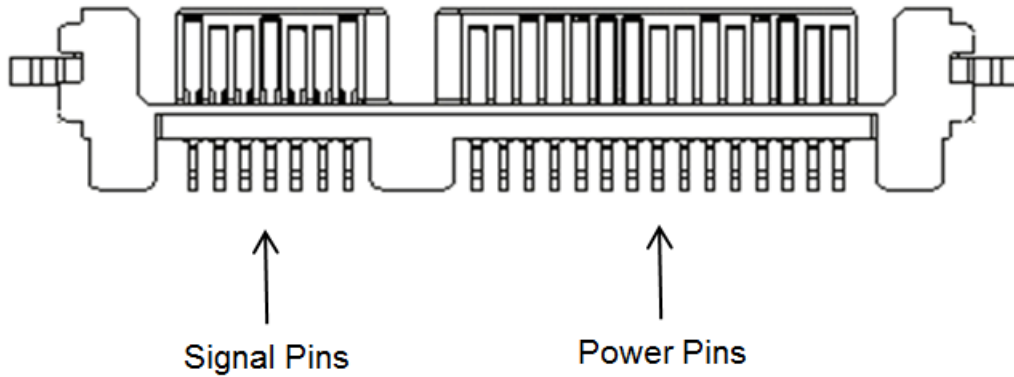

NOTE The 2.5-inch connector supports built in latching capability.

4.3 Connector Pin Signal Definitions

Table 11 Serial ATA Connector Pin Signal Definitions—2.5-inch Form Factors

Pin	Name	Definition
S1	Ground	Ground
S2	A+	Differential signal pair A and A-
S3	A-	
S4	Ground	Ground
S5	B-	Differential signal pair B and B-
S6	B+	
S7	Ground	Ground

NOTE Key and spacing separate the signal and power segments.

4.4 Power Pin Signal Definitions

Table 12 Serial ATA Power Pin Signal Definitions—2.5-inch Form Factors

Pin	Function	Definition
P1	V33	3.3 V Power; not used
P2	V33	3.3 V Power; not used
P3	V33	3.3 V Power; not used
P4	GND	Ground
P5	GND	Ground
P6	GND	Ground
P7	V5	5 V Power
P8	V5	5 V Power
P9	V5	5 V Power
P10	GND	Ground
P11	DAS	Device Activity Signal
P12	GND	Ground
P13	V12	12 V Power; not used
P14	V12	12 V Power; not used
P15	V12	12 V Power; not used

NOTE

Key and spacing separate the signal and power segments.

- Uses 5 V power only, 3.3 V (P1-P3) and 12 V (P13-P15) power are not used.
- Pins P1, P2, and P3; Pins P13, P14, and P15 are connected together. They are not connected internally to the device, and the host may apply voltage on these pins.
- Ground pins are P4, P5, P6, P10, P12.
- Signal pins and the rest of the 5V power pins are P8,P9.
- Power pins P7, P8, and P9 are internally connected to one another within the device

4.5 SSD Activity LED Indicator (Optional)

The Nytro XF1230 can support DAS Control function from the SSD module to indicate LED activity of host side.

The device includes a physical pin P11 for connecting device activity LEDs.

The signal provided to indicate activity of the device is a low-voltage and low-current driver intended for efficient integration into current and future IC manufacturing processes. The signal is not suitable for directly driving an LED and is first buffered using a circuit external to the device before driving an LED.

For DAS function operation, a Firmware function feature and R das are included as an option.

The DAS function firmware feature generates a Low/High toggle Activity signal input when the SSD is in a busy state and generates a high Activity signal input when the SSD is in idle mode (Low level: GND, High level: 3.3V).

Using DAS function increases current because of the Activity LED operation.

The DAS Firmware feature is disabled and the R das is opened when the DAS function is not in use.

Figure 4 Circuit of SSD Activity LED indication

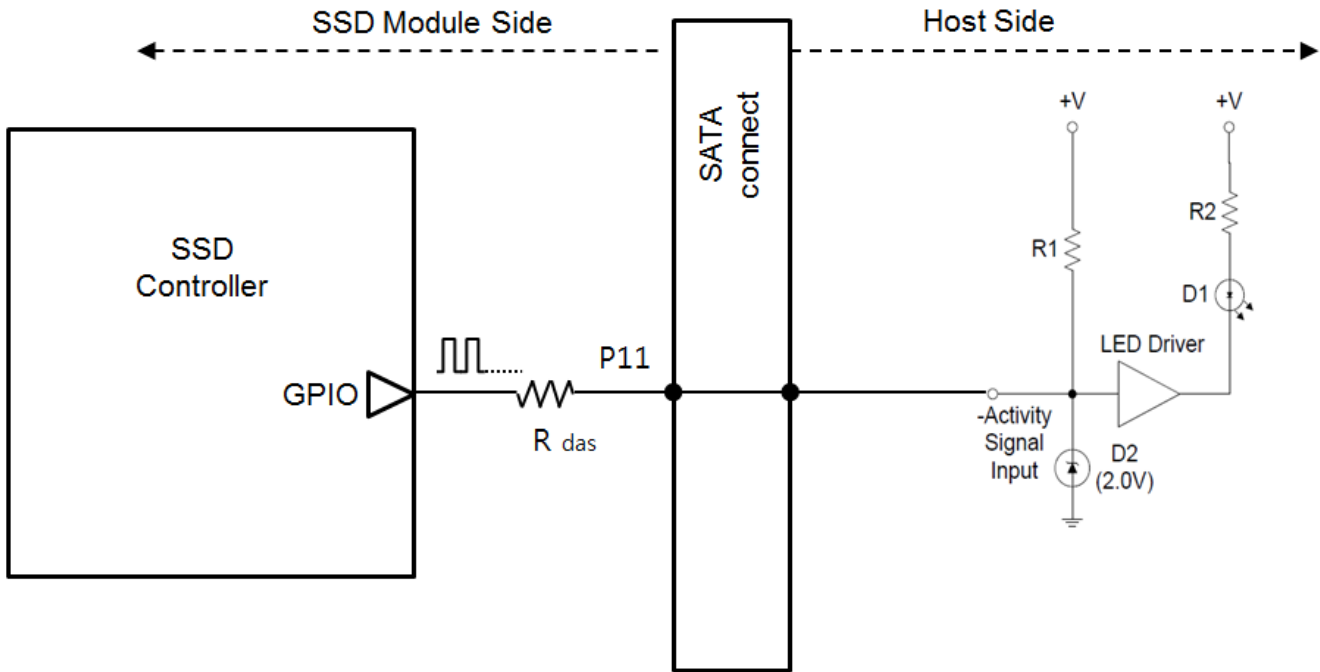

5. Supported ATA Command List

The Nytro XF1230 complies with ATA-8/ACS-4. All mandatory and many optional commands and features are supported.

5.1 ATA Feature Set

The following table shows the ATA feature set and commands that the Nytro XF1230 supports.

Table 13 ATA Feature Set

Feature	Supported
48-Bit Address feature set	Yes
General feature set	Yes
Native Command Queuing (NCQ) feature set	Yes
Power Management feature set	Yes
Security feature set	Yes
SMART feature set	Yes

5.2 ATA Command Description

The following table shows the ATA commands supported.

Table 14 ATA Command Description

Command	Code (Hex)	Command	Code (Hex)
CHECK POWER MODE	E5h	SMART DISABLE OPERATION	B0h/D9h
DATA SET MANAGEMENT	06h	SMART ENABLE/DISABLE	B0h/D2h
DOWNLOAD MICROCODE	92h	SMART ENABLE OPERATION	B0h/D8h
EXECUTE DEVICE DIAGNOSTIC	90h	SMART EXECUTE OFFLINE	B0h/D4h
FLUSH CACHE	E7h	SMART READ DATA	B0h/D0h
FLUSH CACHE EXT	EAh	SMART READ LOG	B0h/D5h
IDENTIFY DEVICE	ECh	SMART READ THRESHOLD	B0h/D1h
IDLE	E3h	SMART RETURN STATUS	B0h/DAh
IDLE IMMEDIATE	E1h	SMART SAVE ATB VALUES	B0h/D3h
INITIALIZE DEVICE PARAMETERS	91h	SMART WRITE LOG	B0h/D6h
NOP	00h	STANDBY	E2h
READ BUFFER	E4h	STANDBY IMMEDIATE	E0h
READ DMA	C8h	WRITE BUFFER	E8h
READ DMA EXT	25h	WRITE DMA	CAh
READ DMA W/O RETRIES	C9h	WRITE DMA EXT	35h
READ FPDMA QUEUED	60h	WRITE DMA FUA EXT	3Dh
READ LOG DMA EXT	47h	WRITE DMA WITHOUT RETRIES	CBh
READ LOG EXT	2Fh	WRITE FPDMA QUEUED	61h
READ MULTIPLE	C4h	WRITE LOG DMA EXT	57h
READ MULTIPLE EXT	29h	WRITE LOG EXT	3Fh

Table 14 ATA Command Description (continued)

Command	Code (Hex)	Command	Code (Hex)
READ SECTOR(S)	20h	WRITE MULTIPLE	C5h
READ SECTOR(S) EXT	24h	WRITE MULTIPLE EXT	39h
READ SECTOR(S) W/O RETRY	21h	WRITE MULTIPLE FUA EXT	CEh
READ VERIFY SECTOR(S)	40h	WRITE SECTOR(S)	30h
READ VERIFY SECTOR(S) W/O RETRY	41h	WRITE SECTOR(S) EXT	34h
READ VERIFY SECTOR(S) EXT	42h	WRITE SECTORS WITHOUT RETRY	31h
RECALIBRATE	10h	WRITE UNCORRECTABLE EXT	45h
REQUEST SENSE DATA EXT	0Bh		
SECURITY DISABLE PASSWORD	F6h		
SECURITY ERASE PREPARE	F3h		
SECURITY ERASE UNIT	F4h		
SECURITY FREEZE LOCK	F5h		
SECURITY SET PASSWORD	F1h		
SECURITY UNLOCK	F2h		
SEEK	70h		
SET FEATURES	EFh		
SET MULTIPLE MODE	C6h		
SLEEP	E6h		

5.3 Security

The user/master password is supported.

When the device receives a normal SECURITY ERASE UNIT command, the device erases all data blocks including unallocated (hidden) blocks.

You can download firmware regardless of the security state.

5.3.1 Password Loss

If you lose the user password, you can access the device using the master password. If both passwords are lost, there is no way to access the device.

6. SMART Support

The Nytro XF1230 supports the SMART Command Set.

6.1 SMART Command Set

The Nytro XF1230 supports the SMART Command Set shown in the following table.

Table 15 SMART Commands

Feature Field Values	Command
D0h	SMART READ DATA
D1h	SMART READ ATTRIBUTE THRESHOLDS
D2h	SMART ENABLE/DISABLE ATTRIBUTE AUTOSAVE
D3h	SAVE ATTRIVUTE VALUES
D4h	SMART EXECUTE OFF-LINE IMMEDIATE
00h*	Execute SMART Off-Line routine
01h*	Execute SMART Short Self-test routine (Off-Line)
02h*	Execute SMART Extended Self-test routine (Off-Line)
03h*	Execute SMART Conveyance self-test routine in off-line mode
04h*	Execute SMART Selective self-test routine in off-line mode
7Fh*	Abort Off-Line routine
81h*	Execute SMART Short Self-test routine (Captive)
82h*	Execute SMART Extended Self-test routine (Captive)
83h*	Execute SMART Conveyance self-test routine in captive mode
84h*	Execute SMART Selective self-test routine in captive mode
D5h	SMART READ LOG
D6h	SMART WRITE LOG
D8h	SMART ENABLE OPERATIONS
D9h	SMART DISABLE OPERATIONS
DAh	SMART RETURN STATUS
*Low LBA values	

6.2 SMART Attributes

The Nytro XF1230 supports the SMART attributes shown in the following table.

Table 16 SMART Attributes

ID	Attribute ID	Description
1	Raw Read Error Rate	Rate of hardware read errors that occurred when reading data from a device
5	Retired Block count	Count of number of blocks that have been reallocated, excluding pending sectors
9	Power on hours	The time accumulated while the power is on and operating
12	Power Cycle Count	Count of number of Power Cycles, excluding power mode commands
174	Unexpected Power Loss Count	Number of Issue on Unexpected Power Loss
175	Program Fail Count (Worst Case Component per die)	Maximum number of Program Error Events per die
176	Erase Fail Count (Worst Case Component per die)	Maximum number of Erase Error Events per die
177	Endurance Limit Met	Indicates the number of NAND wear
178	Used Reserved Block Count (Worst Case Component)	Number of used reserved blocks
179	Used Reserved Block Count (SSD Total)	Number of used reserved blocks in SSD
180	End to End Error Detection / Correction Rate	Number of error detection of the data path between host and NAND in SSD during last power-on
181	Program Fail Count	Number of Error Events on Program (Lifetime)
182	Erase Fail Count	Number of Error Events on Erase (Lifetime)
183	SATA Downshift Count	Number of times that SATA interface speed reduced
184	End to End Error Detection Count	Number of error detection of the data path between host and NAND in SSD of lifetime
187	Reported Uncorrectable Errors	Uncorrectable Error Count
188	Command Timeout Count	Number of total uncompleted commands
189	SSD Health Flags	Indicates PLP health status and Thermal Throttling status
190	SATA Error Counter	Number of encountered SATA error
194	Temperature (Celsius)	Temperature of the SSD
195	ECC On the Fly Rate	Hardware read error rate that occurred when reading data
199	Ultra DMA CRC Error Count	Number of Ultra DMA CRC error count (Lifetime)
201	Read Error Rate	Number of soft read errors (Count of UECC Error)
204	Soft ECC Correction Rate	Count of errors corrected by software ECC[citation needed]
231	SSD Life Left (%)	Indicates the approximate SSD life left, in terms of program/erase cycles or Flash blocks currently available for use.
234	Lifetime NAND programs in GB	Lifetime NAND programs in GB

Table 16 SMART Attributes (continued)

ID	Attribute ID	Description
241	Lifetime Writes From The Host in GB	Track the number of user data in GB written by the host
242	Lifetime Reads From The Host in GB	Track the number of user data in GB read by the host
245	SSD Life Left	Indicates the approximate SSD life left, in terms of program/erase cycles or Flash blocks currently available for use.
250	Total Number of NAND Read Retries	Indicates the total number of NAND read retires.

6.3 SMART Trip

SMART trip (threshold exceeded condition) indicates impending degradation or fault condition. The host can issue a SMART return status command (B0h/DAh) to communicate the reliability status of the drive. The threshold-exceeded condition is also checked during drive self tests.

7. Safety, Standards, and Compliance

7.1 Safety Characteristics

All Seagate SSDs meet or exceed the requirements of UL flammability rating 94V-0. Each bare board is marked with the supplier's name or trademark, type, and UL flammability rating. A CB and UL report has been generated for EN60950.

7.2 Electromagnetic Compliance and Standards

The Nytro XF1230 card is designed to minimize electromagnetic emissions, susceptibility to radio frequency energy, and the effects of electrostatic discharge. The card carries the CE mark, RCM, Canadian Compliance Statement, KCC, Taiwan BSMI, Japan VCCI, and FCC Class B, and the card is marked with the FCC Self-Certification logo. The card also meets the requirements of CISPR Class B.

7.3 Standards

The Nytro XF1230 card is recognized in accordance with UL 60950-1 as tested by UL, CAN/CSA C22.2 No. 60950-1 and IEC/EN60950-1 as tested by TUV SUD.

7.4 Electromagnetic Compatibility



Electromagnetic Compatibility Notices



Electromagnetic Compatibility Notices

This device complies with Part 15 of the FCC Rules. Operation is subject to the following two conditions:

- This device may not cause harmful interference, and
- This device must accept any interference received, including interference that may cause undesired operation.

This equipment has been tested and found to comply with the limits for a Class B digital device, pursuant to part 15 of the FCC Rules. These limits are designed to provide reasonable protection against harmful interference in a residential installation. This equipment generates, uses, and can radiate radio frequency energy and, if not installed and used in accordance with the instructions, may cause harmful interference to radio communications. However, there is no guarantee that interference will not occur in a particular installation. If this equipment does cause harmful interference to radio or television reception, which can be determined by turning the equipment off and on, the user is encouraged to try to correct the interference by one or more of the following measures:

- Reorient or relocate the receiving antenna.
- Increase the separation between the equipment and the receiver.
- Connect the equipment into an outlet on a circuit different from that to which the receiver is connected.
- Consult the dealer or an experienced radio/TV technician for help.

Shielded cables for SCSI connection external to the cabinet are used in the compliance testing of this Product. Seagate is not responsible for any radio or television interference caused by unauthorized modification of this equipment or the substitution or attachment of connecting cables and equipment other than those specified by Seagate Technology LLC. The correction of interferences caused by such unauthorized modification, substitution, or attachment will be the responsibility of the user. The device is tested to comply with FCC standards for home or office use.

This Class B digital apparatus meets all requirements of the Canadian Interference-Causing Equipment Regulations.

Cet appareil numérique de la classe B respecte toutes les exigences du Règlement sur le matériel brouilleur du Canada.

7.5 Electromagnetic Compliance

Seagate uses an independent laboratory to confirm compliance with the directives/standards for CE Marking and C-Tick Marking. The Nytro XF1230 card was tested in a representative system for typical applications and complies with the Electromagnetic Interference/Electromagnetic Susceptibility (EMI/EMS) for Class B products. The selected system represents the most popular characteristics for test platforms. The system configurations include:

- Typical current-use microprocessor
- Keyboard
- Monitor display
- Printer
- Mouse

Although the test system with this Seagate model complies with the directives and standards, we cannot guarantee that all systems comply. The computer or server manufacturer or the system integrator must confirm EMC compliance and provide the appropriate marking for their product.

7.6 Electromagnetic Compliance for the European Union

If this model has the CE Marking it complies with the European Union requirements of the Electromagnetic Compatibility Directive 2004/108/EC as put into place on 20 July 2007.

7.7 Australian RCM

If this model has the RCM Marking it complies with the Australia/New Zealand Standard AS/NZ CISPR22 and meets the Electromagnetic Compatibility (EMC) Framework requirements of Australia's Spectrum Management Agency (SMA).

7.8 Korean KCC

If this model has the Korean Communications Commission (KCC) logo, it complies with KN22, KN 24, and KN61000.

이 기기는 가정용 (B 급) 전자파적합기기로서 주로 가정에서 사용하는 것을 목적으로 하며, 모든 지역에서 사용할 수 있습니다.

This equipment is **home use (Class B) electromagnetic wave suitability equipment** and to be used mainly at home and it can be used in all areas.

7.9 Taiwanese BSMI

If this model has the Taiwanese certification mark then it complies with Chinese National Standard, CNS13438.

7.10 China Requirements — China RoHS 2

China RoHS 2 refers to the Ministry of Industry and Information Technology Order No. 32, effective July 1, 2016, titled Management Methods for the Restriction of the Use of Hazardous Substances in Electrical and Electronic Products. To comply with China RoHS 2, we determined this product's Environmental Protection Use Period (EPUP) to be 20 years in accordance with the *Marking for the Restricted Use of Hazardous Substances in Electronic and Electrical Products*, SJT 11364-2014.

中国电器电子产品有害物质限制使用管理办法

(Management Methods for the Restriction of the Use of Hazardous Substances in Electrical and Electronic Products _ China RoHS)

产品中有害物质的名称及含量

(Name and Content of the Hazardous Substances in Product)



Table 17 Hazardous Substances

部件名称 Part Name	有害物质 Hazardous Substances					
	铅 Lead (Pb)	汞 Mercury (Hg)	镉 Cadmium (Cd)	六价铬 Hexavalent Chromium (CF (VI))	多溴联苯 Polybrominated biphenyls (PBB)	多溴二苯醚 Polybrominated diphenyl ethers (PBDE)
印刷电路板组装 PCBA	X	O	O	O	O	O
机壳 Chassis	X	O	O	O	O	O

本表格依据 SJ/T 11364 的规定编制。
This table is prepared in accordance with the provisions of SJ/T 11364-2014

O: 表示该有害物质在该部件所有均质材料中的含量均在 GB/T 26572 规定的限量要求以下。
O: Indicates that the hazardous substance contained in all of the homogeneous materials for this part is below the limit requirement of GB/T26572.

X: 表示该有害物质至少在该部件的某一均质材料中的含量超出 GB/T 26572 规定的限量要求。
X: Indicates that the hazardous substance contained in at least one of the homogeneous materials used for this part is above the limit requirement of GB/T26572.

7.11 Japan VCCI

この装置は、情報処理装置等電波障害自主規制協議会（VCCI）の基準に基づくクラス B 情報技術装置です。この装置は、家庭環境で使用することを目的としていますが、この装置がラジオやテレビジョン受信機に近接して使用されると、受信障害を引き起こすことがあります。
取扱説明書に従って正しい取り扱いをして下さい。

This is a Class B product based on the standard of the Voluntary Control Council for Interference from Information Technology Equipment (VCCI). If this is used near a radio or television receiver in a domestic environment, it may cause radio interference. Install and use the equipment according to the instruction guide.

7.12 Reference Documents

In case of conflict between this document and any reference document, this document takes precedence.

Table 18 Reference Documents

	Name
Apr. 2007	SATA-IO Commands for ATA-8
Feb. 2011	<i>Solid-State Drive (SSD) Requirements and Endurance Test Method(JESD218A)</i>
Jul. 2011	Serial ATA Revision 3.1
Jul. 2011	IDEMA (LBA1-03_standard.doc)
Jul. 2012	SOLID-STATE DRIVE (SSD) Endurance Workload(JESD219A)
Jul. 2015	ATA/ATAPI Command Set -4 (ACS-4) Working Draft
Nov. 2011	ISO/IEC 14776-xxxSCSI Block Commands-3 (SBC-3) Standard (T10/1799-D)



Seagate Technology LLC

AMERICAS Seagate Technology LLC 10200 South De Anza Boulevard, Cupertino, California 95014, United States, 408-658-1000

ASIA/PACIFIC Seagate Singapore International Headquarters Pte. Ltd. 7000 Ang Mo Kio Avenue 5, Singapore 569877, 65-6485-3888

EUROPE, MIDDLE EAST AND AFRICA Seagate Technology SAS 16-18 rue du Dôme, 92100 Boulogne-Billancourt, France, 33 1-4186 10 00

Publication Number: 100797573, Rev. E

October 2016