

A decorative graphic on the left side of the page featuring a large dashed circle, a solid blue circle, and several overlapping curved lines in blue and grey.

Product Manual

Momentum 5400.4 SATA

ST9250827AS

ST9200827AS

ST9160827AS

ST9120817AS

100468842
Rev. A
October 2007

Revision history

Revision	Date	Comments
Rev. A	10/23/07	Initial release.

Copyright © 2007 Seagate Technology LLC. All rights reserved. Printed in U.S.A.

Publication number: 100468842, Rev. A October 2007

Seagate, Seagate Technology and the Wave logo are registered trademarks of Seagate Technology LLC in the United States and/or other countries. Momentus, SeaTools and SeaTDD are either trademarks or registered trademarks of Seagate Technology LLC or one of its affiliated companies in the United States and/or other countries. All other trademarks or registered trademarks are the property of their respective owners.

One gigabyte, or GB, equals one billion bytes when referring to hard drive capacity. Accessible capacity may vary depending on operating environment and formatting. Quantitative usage examples for various applications are for illustrative purposes. Actual quantities will vary based on various factors, including file size, file format, features and application software. Seagate reserves the right to change, without notice, product offerings or specifications.

Contents

1.0	Introduction	1
1.1	About the Serial ATA interface	2
2.0	Drive specifications	3
2.1	Specification summary table	3
2.2	Formatted capacity	5
2.2.1	LBA mode	5
2.3	Default logical geometry	5
2.4	Physical organization	6
2.5	Recording and interface technology	6
2.6	Physical characteristics	6
2.7	Seek time	7
2.8	Start/stop times	7
2.9	Power specifications	8
2.9.1	Power consumption	8
2.9.2	Deferred spinup	9
2.9.3	Conducted noise	9
2.9.4	Voltage tolerance	9
2.9.5	Power-management modes	10
2.10	Environmental specifications	11
2.10.1	Ambient temperature	11
2.10.2	Temperature gradient	11
2.10.3	Humidity	11
2.10.4	Altitude	11
2.10.5	Shock	12
2.10.6	Vibration	12
2.11	Acoustic emission	13
2.12	Electromagnetic immunity	13
2.13	Reliability	14
2.14	Agency certification	14
2.14.1	Safety certification	14
2.14.2	Electromagnetic compatibility	14
2.14.3	FCC verification	15
2.15	Environmental protection	16
2.15.1	European Union Restriction of Hazardous Substances (RoHS)	16
2.16	Corrosive environment	16
3.0	Configuring and mounting the drive	17
3.1	Handling and static-discharge precautions	17
3.2	Configuring the drive	18
3.3	Serial ATA cables and connectors	18
3.4	Drive mounting	19
4.0	Serial ATA (SATA) interface	21
4.1	Hot-Plug compatibility	21
4.2	Serial ATA device plug connector pin definitions	21
4.3	Supported ATA commands	23
4.3.1	Identify Device command	26
4.3.2	Set Features command	29
4.3.3	S.M.A.R.T. commands	30
5.0	Seagate Technology support services	31

List of Figures

Figure 1.	Typical +5V only startup and operation current profile	9
Figure 2.	Serial ATA connectors and jumper options	18
Figure 3.	Attaching SATA cabling	18
Figure 4.	Mounting dimensions—top, side and end view	19

1.0 Introduction

This manual describes the functional, mechanical and interface specifications for the following Seagate Momentus® 5400.4 SATA model drives:

- ST9250827AS
- ST9200827AS
- ST9160827AS
- ST9120817AS

These drives provide the following key features:

- 5,400-RPM spindle speed.
- 8-Mbyte buffer.
- Quiet operation. Fluid Dynamic Bearing (FDB) motor.
- High instantaneous (burst) data-transfer rates (up to 150 Mbytes per second).
- Perpendicular recording technology provides the drives with increased areal density.
- State-of-the-art cache and on-the-fly error-correction algorithms.
- Full-track multiple-sector transfer capability without local processor intervention.
- 900 Gs nonoperating shock and 325 Gs of operating shock.
- SeaTools diagnostic software performs a drive self-test that eliminates unnecessary drive returns.
- The 3D Defense System™, which includes Drive Defense, Data Defense and Diagnostic Defense, offers the industry's most comprehensive protection for disc drives.
- Support for S.M.A.R.T. drive monitoring and reporting.
- Support for Read Multiple and Write Multiple commands.

1.1 About the Serial ATA interface

The Serial ATA interface provides several advantages over the traditional (parallel) ATA interface. The primary advantages include:

- Easy installation and configuration with true plug-and-play connectivity. It is not normally necessary to set any jumpers or other configuration options.
- Thinner and more flexible cabling for improved enclosure airflow and ease of installation.
- Scalability to higher performance levels.

In addition, Serial ATA makes the transition from parallel ATA easy by providing legacy software support. Serial ATA was designed to allow you to install a Serial ATA host adapter and Serial ATA disc drive in your current system and expect all of your existing applications to work as normal.

The Serial ATA interface connects each disc drive in a point-to-point configuration with the Serial ATA host adapter. There is no master/slave relationship with Serial ATA devices like there is with parallel ATA. If two drives are attached on one Serial ATA host adapter, the host operating system views the two devices as if they were both “masters” on two separate ports. This essentially means both drives behave as if they are Device 0 (master) devices.

Note. The host adapter may, optionally, emulate a master/slave environment to host software where two devices on separate Serial ATA ports are represented to host software as a Device 0 (master) and Device 1 (slave) accessed at the same set of host bus addresses. A host adapter that emulates a master/slave environment manages two sets of shadow registers. This is not a typical Serial ATA environment.

The Serial ATA host adapter and drive share the function of emulating parallel ATA device behavior to provide backward compatibility with existing host systems and software. The Command and Control Block registers, PIO and DMA data transfers, resets, and interrupts are all emulated.

The Serial ATA host adapter contains a set of registers that shadow the contents of the traditional device registers, referred to as the Shadow Register Block. All Serial ATA devices behave like Device 0 devices. For additional information about how Serial ATA emulates parallel ATA, refer to the “Serial ATA: High Speed Serialized AT Attachment” specification. The specification can be downloaded from <http://www.serialata.org>.

2.0 Drive specifications

Unless otherwise noted, all specifications are measured under ambient conditions, at 25°C, and nominal power. For convenience, the phrases *the drive* and *this drive* are used throughout this manual to indicate the ST9250827AS, ST9200827AS, ST9160827AS, and ST9120817AS models.

2.1 Specification summary table

The specifications listed in this table are for quick reference. For details on specification measurement or definition, see the appropriate section of this manual.

Table 1: Drive specifications

Drive specification	ST9250827AS	ST9200827AS	ST9160827AS	ST9120817AS
Formatted Gbytes (512 bytes/sector)*	250	200	160	120
Guaranteed sectors	488,397,168	390,721,968	312,581,808	234,441,648
Bytes per sector	512			
Physical read/write heads	4	4	3	2
Discs	2	2	2	1
Cache (Mbytes)	8			
Recording density in BPI (bits/inch max)	1,180k			
Track density TPI (tracks/inch max)	173k			
Areal density (Gbits/inch ² max)	204			
Spindle speed (RPM)	5,400			
Internal transfer rate (Mbits/sec max)	778			
Sustained transfer rate (Mbytes/sec max)	58			
I/O data transfer rate (Mbytes/sec max)	300			
ATA data-transfer modes supported	SATA 1.0, Serial ATA Revision 2.5 PIO modes 0–4 Multiword DMA modes 0–2 Ultra DMA modes 0–6			
Height (max)	9.5 +/- 0.2 mm (0.374 +/- .0078 inches)			
Width (max)	69.85 +/- 0.25 mm (2.75 +/- 0.0098 inches)			
Length (max)	100.20 +/- 0.25 mm (3.945 +/- 0.010 inches)			
Weight (typical)	<=102 grams (0.23 lb)			97 grams (0.21 lb)
Average latency (msec)	5.6			
Power-on to ready (sec typical)	<3.0			
Standby to ready (sec typical)	<2.0			
Track-to-track seek time (msec typical)	<2.0 (read), <2.5 (write)			
Average seek, read (msec typical)	<12.0			
Average seek, write (msec typical)	<14.0			

Table 1: Drive specifications

Drive specification	ST9250827AS	ST9200827AS	ST9160827AS	ST9120817AS
Full-stroke seek (msec)	20 (typical); 24 (max)			
Startup current, +5V (typical)	1.0 amps			
Seek power (typical)	2.0 watts			
Read/write power (typical)	Read: 2.0 watts; Write: 1.6 watts			
Idle mode, low power (typical)	0.6 watts			
Standby mode	0.20 watts (typical)***			
Sleep mode	0.20 watts (typical)***			
Voltage tolerance (including noise)	+5V ± 5%			
Ambient operating temperature	0° to 60°C (operating), -40° to 70°C (nonoperating)			
Temperature gradient (°C per hour max)	20°C (operating) 35°C (nonoperating)			
Relative humidity	5% to 95% (operating) 5% to 95% (nonoperating)			
Relative humidity gradient	30% per hour max			
Wet bulb temperature (°C max)	37.7 (operating) 40 (nonoperating)			
Altitude, operating	-304.8 m to 3,048 m (-1,000 ft to 10,000+ ft)			
Altitude, nonoperating (meters below mean sea level, max)	-304.8 m to 12,192 m (-1000 ft to 40,000+ ft)			
Shock, operating (Gs max at 2 msec)	325			
Shock, nonoperating (Gs max at 2 msec)	800			
Shock, nonoperating (Gs max at 1 msec)	900			
Shock, nonoperating (Gs max at 0.5 msec)	600			
Vibration, operating	1.5 G (0 to peak, 5–500 Hz)			
Vibration, nonoperating	5 Gs (0 to peak, 5–500 Hz)			
Drive acoustics, sound power (bels)				
Idle**	2.4 (typical) 2.6 (max)			
Performance seek	2.6 (typical) 2.8 (max)			
Nonrecoverable read errors	1 per 10 ¹⁴ bits read			
Annualized Failure Rate (AFR)	0.7%			
Load/Unload (U/UL) cycles				
25°C, 50% relative humidity	600,000 software-controlled power on/off cycles 20,000 hard power on/off cycles			
32°C, 80% relative humidity 5°C, 80% relative humidity 5°C, 10% relative humidity 55°C, 16% relative humidity	600,000 software-controlled power on/off cycles 20,000 hard power on/off cycles			
Warranty	5 years on distribution units. To determine the warranty for a specific drive, use a web browser to access the following web page: www.seagate.com/support/service/ From this page, click on the "Verify Your Warranty" link. You will be asked to provide the drive serial number, model number (or part number) and country of purchase. The system will display the warranty information for your drive.			
Supports Hotplug operation per Serial ATA Revision 2.5 specification	Yes (requires COMPRESET from host after a hotplug event)			

*One Gbyte equals one billion bytes when referring to hard drive capacity. Accessible capacity may vary depending on operating environment and formatting.

**During periods of drive idle, some offline activity may occur according to the S.M.A.R.T. specification, which may increase acoustic and power to operational levels.

***Typical notebooks will pull power to the drive when entering S3 and S4; while in the S3 and S4 states, drive sleep and drive standby modes will not contribute to battery power consumption.

2.2 Formatted capacity

Model	Formatted capacity*	Guaranteed sectors	Bytes per sector
ST9250827AS	250 Gbytes	488,397,168	512
ST9200827AS	200 Gbytes	390,721,968	512
ST9160827AS	160 Gbytes	312,581,808	512
ST9120817AS	120 Gbytes	234,441,648	512

*One Gbyte equals one billion bytes when referring to hard drive capacity. Accessible capacity may vary depending on operating environment and formatting.

2.2.1 LBA mode

When addressing these drives in LBA mode, all blocks (sectors) are consecutively numbered from 0 to $n-1$, where n is the number of guaranteed sectors as defined above.

See Section 4.3.1, "Identify Device command" (words 60-61 and 100-103) for additional information about 48-bit addressing support of drives with capacities over 137 Gbytes.

2.3 Default logical geometry

Cylinders	Read/write heads	Sectors per track
16,383	16	63

LBA mode

When addressing these drives in LBA mode, all blocks (sectors) are consecutively numbered from 0 to $n-1$, where n is the number of guaranteed sectors as defined above.

2.4 Physical organization

Drive model	Read/write heads	Number of discs
ST9250827AS	4	2
ST9200827AS	4	2
ST9160827AS	3	2
ST9120817AS	2	1

2.5 Recording and interface technology

Interface	Serial ATA (SATA)
Recording method	Perpendicular
Recording density BPI (bits/inch max)	1,180k
Track density TPI (tracks/inch max)	173k
Areal density (Gbits/inch ² max)	204
Spindle speed (RPM) (\pm 0.2%)	5,400
Internal transfer rate (Mbits/sec, max)	778
Sustained transfer rate (Mbytes/sec, max)	58
I/O data-transfer rate (Mbytes/sec max)	300
Interleave	1:1
Cache buffer	8 Mbytes (8,192 kbytes)

2.6 Physical characteristics

Drive specification	
Height (mm) (inches)	9.5 +/-0.2 0.374 +/-0.0078
Width (mm) (inches)	69.85 +/-0.25 2.75 +/-0.0098
Length (mm) (inches)	100.20 +/-0.25 3.945 +/-0.010
Typical weight ST9250827AS ST9200827AS ST9160827AS ST9120817AS	102 grams 0.23 pounds 97 grams 0.21 pounds

2.7 Seek time

Seek measurements are taken with nominal power at 25°C ambient temperature. All times are measured using drive diagnostics. The specifications in the table below are defined as follows:

- Track-to-track seek time is an average of all possible single-track seeks in both directions.
- Average seek time is a true statistical random average of at least 5,000 measurements of seeks between random tracks, less overhead.

Table 2: Typical seek times

Typical seek times (msec)	Read	Write
Track-to-track	<2.0	<2.5
Average	<12.0	<14.0
Full-stroke	20.0	24.0
Average latency	5.56	5.56

Note. These drives are designed to consistently meet the seek times represented in this manual. Physical seeks, regardless of mode (such as track-to-track and average), are expected to meet the noted values. However, due to the manner in which these drives are formatted, benchmark tests that include command overhead or measure logical seeks may produce results that vary from these specifications.

2.8 Start/stop times

Time to ready	Typical	Max @ 25°C
Power-on to Ready (sec)	<3.0	8.0
Standby to Ready (sec)	<2.0	8.0

2.9 Power specifications

The drive receives DC power (+5V) through a native SATA power connector.

2.9.1 Power consumption

Power requirements for the drives are listed in the table on page 8. Typical power measurements are based on an average of drives tested, under nominal conditions, at 25°C ambient temperature.

- **Spinup power**

Spinup power is measured from the time of power-on to the time that the drive spindle reaches operating speed.

- **Seek mode**

During seek mode, the read/write actuator arm moves toward a specific position on the disc surface and does not execute a read or write operation. Servo electronics are active. Seek mode power is measured based on three random seek operations every 100 msecs. This mode is not typical.

- **Read/write power and current**

Read/write power is measured with the heads on track, based on three 63 sector read or write operations every 100 msecs.

- **Idle mode power**

Idle mode power is measured with the drive up to speed, with servo electronics active and with the heads in a random track location.

- **Standby mode**

During Standby mode, the drive accepts commands, but the drive is not spinning, and the servo and read/write electronics are in power-down model

Table 3: DC power

Power dissipation	+5V input average (25° C)
Spinup (typical)	1.0 amps
Seek	2.0 watts
Read	2.0 watts
Write	1.6 watts
Idle, performance*	1.4 watts
Idle, active*	0.75 watts
Idle, low power mode*	0.6 watts
Standby	0.20 watts
Sleep	0.20 watts

*During periods of drive idle, some offline activity may occur according to the S.M.A.R.T. specification, which may increase acoustic and power to operational levels.

2.9.1.1 Typical current profile

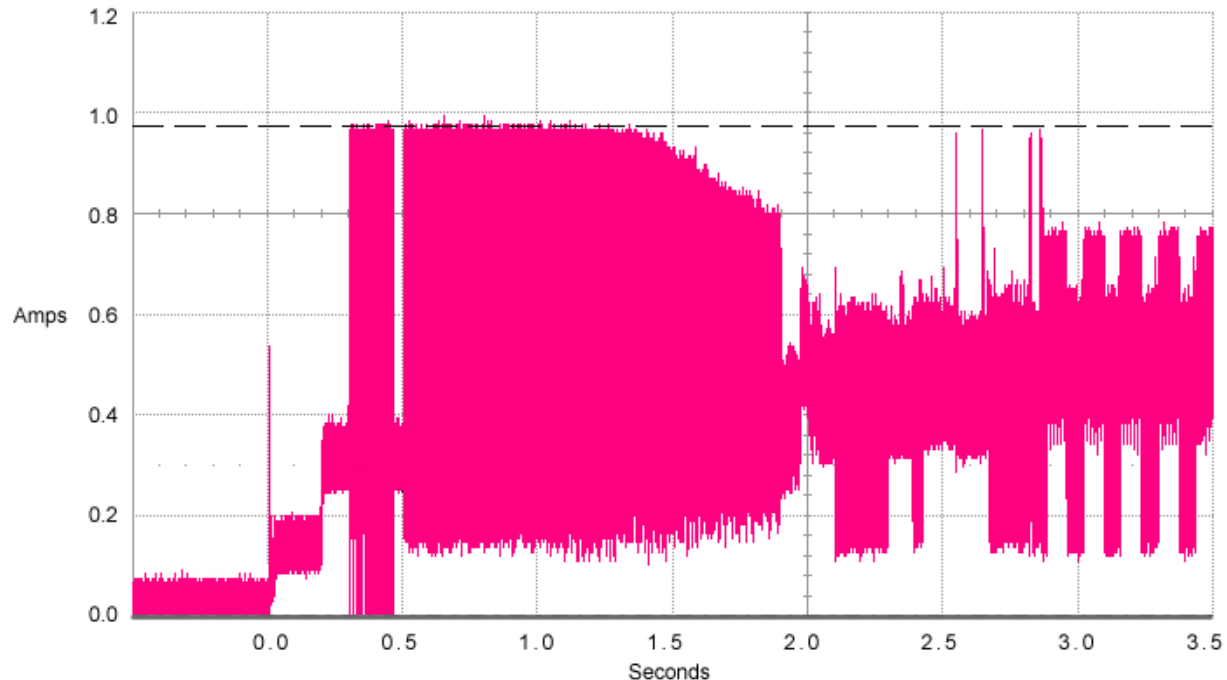

Figure 1. Typical +5V only startup and operation current profile

2.9.2 Deferred spinup

Momentus 5400.4 SATA drives do not support the deferred spinup option. If you require this option, refer to the Momentus 5400.3 SATA Blade Server family of drives.

2.9.3 Conducted noise

Input noise ripple is measured at the host system power supply across an equivalent 15-ohm resistive load on the +5 volt line.

Using 5-volt power, the drive is expected to operate with a maximum of 100 mV peak-to-peak square-wave injected noise at up to 10 MHz.

Note. Equivalent resistance is calculated by dividing the nominal voltage by the typical RMS read/write current.

2.9.4 Voltage tolerance

Voltage tolerance (including noise):

5V \pm 5%

2.9.5 Power-management modes

The drive provides programmable power management to provide greater energy efficiency. In most systems, you can control power management through the system setup program. The drive features the following power-management modes:

Table 4: Power management modes

Power modes	Heads	Spindle	Buffer
Active (operating)	Tracking	Rotating	Full power
Idle, performance	Tracking	Rotating	Low power
Idle, active	Bias against crash stops	Rotating	Self refresh—low power
Idle, low power	Parked	Rotating	Self refresh—low power
Standby	Parked	Stopped	Self refresh—low power
Sleep	Parked	Stopped	Self refresh—low power

- **Active mode**

The drive is in Active mode during the read/write and seek operations.

- **Idle mode**

The buffer remains enabled, and the drive accepts all commands and returns to Active mode any time disc access is necessary.

- **Standby mode**

The drive enters Standby mode when the host sends a Standby Immediate command. If the host has set the standby timer, the drive can also enter Standby mode automatically after the drive has been inactive for a specifiable length of time. The standby timer delay is established using a Standby or Idle command. In Standby mode, the drive buffer is in Self Refresh Low Power mode, the heads are parked and the spindle is at rest. The drive accepts all commands and returns to Active mode any time disc access is necessary.

- **Sleep mode**

The drive enters Sleep mode after receiving a Sleep command from the host. In Sleep mode, the drive buffer is in Self Refresh Low Power mode, the heads are parked and the spindle is at rest. The drive leaves Sleep mode after it receives a Hard Reset or Soft Reset from the host. After receiving a reset, the drive exits Sleep mode and enters Standby mode with all current translation parameters intact.

- **Idle and Standby timers**

Each time the drive performs an Active function (read, write or seek), the standby timer is reinitialized and begins counting down from its specified delay times to zero. If the standby timer reaches zero before any drive activity is required, the drive makes a transition to Standby mode. In both Idle and Standby mode, the drive accepts all commands and returns to Active mode when disc access is necessary.

2.10 Environmental specifications

2.10.1 Ambient temperature

Ambient temperature is defined as the temperature of the environment immediately surrounding the drive. Actual drive case temperature should not exceed 65°C (149°F) within the operating ambient conditions.

Operating:	0° to 60°C (32° to 140°F)
Nonoperating:	–40° to 70°C (–40° to 158°F)

2.10.2 Temperature gradient

Operating	20°C per hour (68°F per hour max), without condensation
Nonoperating	35°C per hour (86°F per hour max), without condensation

2.10.3 Humidity

2.10.3.1 Relative humidity

Operating	5% to 95% noncondensing (30% per hour max)
Nonoperating	5% to 95% noncondensing (30% per hour max)

2.10.3.2 Wet bulb temperature

Operating	37.7°C (86°F max)
Nonoperating	40°C (104°F max)

2.10.4 Altitude

Operating	–304.8 m to 3,048 m (–1,000 ft to 10,000+ ft)
Nonoperating	–304.8 m to 12,192 m (–1,000 ft to 40,000+ ft)

2.10.5 Shock

All shock specifications assume that the drive is mounted securely with the input shock applied at the drive mounting screws. Shock may be applied in the X, Y or Z axis.

2.10.5.1 Operating shock

These drives comply with the performance levels specified in this document when subjected to a maximum operating shock of 325 Gs based on half-sine shock pulses of 2 msec. Shocks should not be repeated more than two times per second.

2.10.5.2 Nonoperating shock

The nonoperating shock level that the drive can experience without incurring physical damage or degradation in performance when subsequently put into operation is 800 Gs based on a nonrepetitive half-sine shock pulse of 2 msec duration.

The nonoperating shock level that the drive can experience without incurring physical damage or degradation in performance when subsequently put into operation is 900 Gs based on a nonrepetitive half-sine shock pulse of 1 msec duration.

The nonoperating shock level that the drive can experience without incurring physical damage or degradation in performance when subsequently put into operation is 600 Gs based on a nonrepetitive half-sine shock pulse of 0.5 msec duration.

2.10.6 Vibration

All vibration specifications assume that the drive is mounted securely with the input vibration applied at the drive mounting screws. Vibration may be applied in the X, Y or Z axis.

2.10.6.1 Operating vibration

The maximum vibration levels that the drive may experience while meeting the performance standards specified in this document are specified below.

5–500 Hz	1.5 Gs (0 to peak). Max displacement may apply below 10 Hz.
----------	---

2.10.6.2 Nonoperating vibration

The maximum nonoperating vibration levels that the drive may experience without incurring physical damage or degradation in performance when subsequently put into operation are specified below.

10–500 Hz:	5.0 Gs (0 to peak). Max displacement may apply below 22 Hz.
------------	---

2.11 Acoustic emission

Drive emission of sound is measured consistent with the ECMA-74 and its' referenced standards. Testing is conducted at room temperature (approximately 25C). Emission levels are reported as the total A-weighted sound power levels for, steady state, idle and active (seek) modes of operations.

Table 5: Drive level acoustics

Models		Idle*	Performance seek
2 discs	ST9250827AS	2.4 bels (typ)	2.6 bels (typ)
	ST9200827AS	2.6 bels (max)	2.8 bels (max)
	ST9160827AS		
1 disc	ST9120817AS	2.2 bels (typ) 2.4 bels (max)	2.9 bels (typ) 3.1 bels (max)

*During periods of drive idle, some offline activity may occur according to the S.M.A.R.T. specification, which may increase acoustic and power to operational levels.

Test for Prominent Discrete Tones (PDTs)

Seagate follows the ECMA-74 standards for measurement and identification of PDTs. An exception to this process is the use of the absolute threshold of hearing. Seagate uses the lower limit for the threshold curve* to discern tone audibility and to compensate for the inaudible components of sound prior to computation of tone ratios according to Annex D of the ECMA-74 standards.

* Defined as the median curve given by ISO 389-7 (Tf curve) minus 10dB at all frequencies.

2.12 Electromagnetic immunity

When properly installed in a representative host system, the drive operates without errors or degradation in performance when subjected to the radio frequency (RF) environments defined in the following table:

Table 6: Radio frequency environments

Test	Description	Performance level	Reference standard
Electrostatic discharge	Contact, HCP, VCP: ± 4 kV; Air: ± 8 kV	B	EN 61000-4-2: 95
Radiated RF immunity	80 to 2,000 MHz, 10 V/m, 80% AM with 1 kHz sine 900 MHz, 3 V/m, 50% pulse modulation @ 200 Hz	A	EN 61000-4-3: 96 ENV 50204: 95
Electrical fast transient	± 1 kV on AC mains, ± 0.5 kV on external I/O	B	EN 61000-4-4: 95
Surge immunity	± 1 kV differential, ± 2 kV common, AC mains	B	EN 61000-4-5: 95
Conducted RF immunity	150 kHz to 80 MHz, 3 Vrms, 80% AM with 1 kHz sine	A	EN 61000-4-6: 97
Power Frequency H-field immunity	1 A/m, 50Hz/60Hz, 3 axes	A	EN 61000-4-8: 97
Voltage dips, interrupts	30% Reduction for 25 cycles >95% Reduction for 250 cycles >95%, 0.5 cycles	C C B	EN 61000-4-11: 94

2.13 Reliability

Measurement type	Specification
Nonrecoverable read errors	1 per 10 ¹⁴ bits read, max.
Annualized Failure Rate (AFR)	0.7%
Load/Unload (U/UL) 25°C, 50% relative humidity 32°C, 80% relative humidity 5°C, 80% relative humidity 5°C, 10% relative humidity 55°C, 16% relative humidity	 600,000 software-controlled power on/off cycles 20,000 hard power on/off cycles 600,000 software-controlled power on/off cycles 20,000 hard power on/off cycles
Warranty	5 years on distribution units. To determine the warranty for a specific drive, use a web browser to access the following web page: www.seagate.com/support/service/ From this page, click on the “Verify Your Warranty” link. You will be asked to provide the drive serial number, model number (or part number) and country of purchase. The system will display the warranty information for your drive.

2.14 Agency certification

2.14.1 Safety certification

The drives are recognized in accordance with UL 1950 and CSA C22.2 (950) and meet all applicable sections of IEC950 and EN 60950 as tested by TUV North America.

2.14.2 Electromagnetic compatibility

Hard drives that display the CE mark comply with the European Union (EU) requirements specified in the Electromagnetic Compatibility Directive (89/336/EEC). Testing is performed to the levels specified by the product standards for Information Technology Equipment (ITE). Emission levels are defined by EN 55022, Class B and the immunity levels are defined by EN 55024.

Seagate uses an independent laboratory to confirm compliance with the EC directives specified in the previous paragraph. Drives are tested in representative end-user systems. Although CE-marked Seagate drives comply with the directives when used in the test systems, we cannot guarantee that all systems will comply with the directives. The drive is designed for operation inside a properly designed enclosure, with properly shielded I/O cable (if necessary) and terminators on all unused I/O ports. Computer manufacturers and system integrators should confirm EMC compliance and provide CE marking for their products.

Korean RRL

If these drives have the Korea Ministry of Information and Communication (MIC) logo, they comply with paragraph 1 of Article 11 of the Electromagnetic Compatibility control Regulation and meet the Electromagnetic Compatibility (EMC) Framework requirements of the Radio Research Laboratory (RRL) Ministry of Information and Communication Republic of Korea.

These drives have been tested and comply with the Electromagnetic Interference/Electromagnetic Susceptibility (EMI/EMS) for Class B products. Drives are tested in a representative, end-user system by a Korean-recognized lab.

- Certificate number: Pending (B)
- Trade name or applicant: Seagate Technology
- Manufacturing date: November 2007
- Manufacturer/nationality: USA, Singapore and China

Australian C-Tick (N176)

If these models have the C-Tick marking, they comply with the Australia/New Zealand Standard AS/NZS3548 1995 and meet the Electromagnetic Compatibility (EMC) Framework requirements of the Australian Communication Authority (ACA).

2.14.3 FCC verification

These drives are intended to be contained solely within a personal computer or similar enclosure (not attached as an external device). As such, each drive is considered to be a subassembly even when it is individually marketed to the customer. As a subassembly, no Federal Communications Commission verification or certification of the device is required.

Seagate Technology LLC has tested this device in enclosures as described above to ensure that the total assembly (enclosure, disc drive, motherboard, power supply, etc.) does comply with the limits for a Class B computing device, pursuant to Subpart J, Part 15 of the FCC rules. Operation with noncertified assemblies is likely to result in interference to radio and television reception.

Radio and television interference. This equipment generates and uses radio frequency energy and if not installed and used in strict accordance with the manufacturer's instructions, may cause interference to radio and television reception.

This equipment is designed to provide reasonable protection against such interference in a residential installation. However, there is no guarantee that interference will not occur in a particular installation. If this equipment does cause interference to radio or television, which can be determined by turning the equipment on and off, you are encouraged to try one or more of the following corrective measures:

- Reorient the receiving antenna.
- Move the device to one side or the other of the radio or TV.
- Move the device farther away from the radio or TV.
- Plug the computer into a different outlet so that the receiver and computer are on different branch outlets.

If necessary, you should consult your dealer or an experienced radio/television technician for additional suggestions. You may find helpful the following booklet prepared by the Federal Communications Commission: *How to Identify and Resolve Radio-Television Interference Problems*. This booklet is available from the Superintendent of Documents, U.S. Government Printing Office, Washington, DC 20402. Refer to publication number 004-000-00345-4.

2.15 Environmental protection

Seagate designs its products to meet environmental protection requirements worldwide, including regulations restricting certain chemical substances.

2.15.1 European Union Restriction of Hazardous Substances (RoHS)

The European Union Restriction of Hazardous Substances (RoHS) Directive restricts the presence of chemical substances, including Lead (Pb), in electronic products effective July 2006.

A number of parts and materials in Seagate products are procured from external suppliers. We rely on the representations of our suppliers regarding the presence of RoHS substances in these parts and materials. Our supplier contracts require compliance with our chemical substance restrictions, and our suppliers document their compliance with our requirements by providing material content declarations for all parts and materials for the disc drives documented in this publication. Current supplier declarations include disclosure of the inclusion of any RoHS-regulated substance in such parts or materials.

Seagate also has internal systems in place to ensure ongoing compliance with the RoHS Directive and all laws and regulations which restrict chemical content in electronic products. These systems include standard operating procedures that ensure that restricted substances are not utilized in our manufacturing operations, laboratory analytical validation testing, and an internal auditing process to ensure that all standard operating procedures are complied with.

2.16 Corrosive environment

Seagate electronic drive components pass accelerated corrosion testing equivalent to 10 years exposure to light industrial environments containing sulfurous gases, chlorine and nitric oxide, classes G and H per ASTM B845. However, this accelerated testing cannot duplicate every potential application environment.

Users should use caution exposing any electronic components to uncontrolled chemical pollutants and corrosive chemicals as electronic drive component reliability can be affected by the installation environment. The silver, copper, nickel and gold films used in Seagate products are especially sensitive to the presence of sulfide, chloride, and nitrate contaminants. Sulfur is found to be the most damaging. In addition, electronic components should never be exposed to condensing water on the surface of the printed circuit board assembly (PCBA) or exposed to an ambient relative humidity greater than 95%. Materials used in cabinet fabrication, such as vulcanized rubber, that can outgas corrosive compounds should be minimized or eliminated. The useful life of any electronic equipment may be extended by replacing materials near circuitry with sulfide-free alternatives.

3.0 Configuring and mounting the drive

This section contains the specifications and instructions for configuring and mounting the drive.

3.1 Handling and static-discharge precautions

After unpacking, and before installation, the drive may be exposed to potential handling and electrostatic discharge (ESD) hazards. Observe the following standard handling and static-discharge precautions:

Caution:

- Keep the drive in the electrostatic discharge (ESD) bag until you are ready for installation to limit the drive's exposure to ESD.
- Before handling the drive, put on a grounded wrist strap, or ground yourself frequently by touching the metal chassis of a computer that is plugged into a grounded outlet. Wear a grounded wrist strap throughout the entire installation procedure.
- Handle the drive only by its edges or frame.
- The drive is fragile—handle it with care. Do not press down on the drive top cover.
- Always rest the drive on a padded, antistatic surface until you mount it in the computer.
- Do not touch the connector pins or the printed circuit board.
- Do not remove the factory-installed labels from the drive or cover them with additional labels. Removal voids the warranty. Some factory-installed labels contain information needed to service the drive. Other labels are used to seal out dirt and contamination.

3.2 Configuring the drive

Each drive on the Serial ATA interface connects in a point-to-point configuration with the Serial ATA host adapter. There is no master/slave relationship because each drive is considered a master in a point-to-point relationships. If two drives are attached on one Serial ATA host adapter, the host operating system views the two devices as if they were both “masters” on two separate ports. This means both drives behave as if they are Device 0 (master) devices.

Serial ATA drives are designed for easy installation. It is normally not necessary to set any jumpers on this drive for proper operation. If the host system does not support SATA 3Gb/s operation, place a jumper on pins 1 and 2 to limit the drive to 1.5Gb/s.

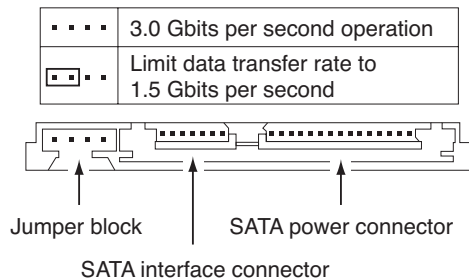

Figure 2. Serial ATA connectors and jumper options

3.3 Serial ATA cables and connectors

The Serial ATA interface cable consists of four conductors in two differential pairs, plus three ground connections. The cable size may be 30 to 26 AWG with a maximum length of one meter (39.37 inches). See Table 7 for connector pin definitions. Either end of the SATA signal cable can be attached to the drive or host.

For direct backplane connection, the drive connectors are inserted directly into the host receptacle. The drive and the host receptacle incorporate features that enable the direct connection to be hot pluggable and blind mateable.

For installations which require cables, you can connect the drive as illustrated in Figure 3.

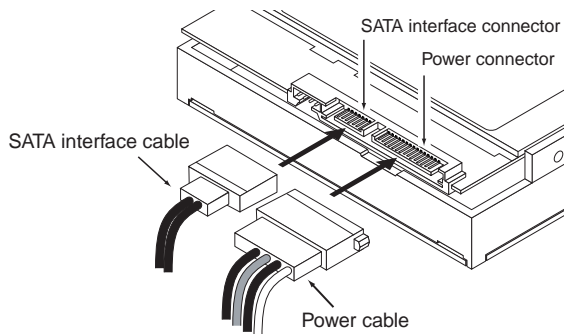

Figure 3. Attaching SATA cabling

Each cable is keyed to ensure correct orientation.

3.4 Drive mounting

You can mount the drive using four screws in the side-mounting holes or four screws in the bottom-mounting holes. See Figure 4 for drive mounting dimensions. Follow these important mounting precautions when mounting the drive:

- Allow a minimum clearance of 0.030 inches (0.76 mm) around the entire perimeter of the drive for cooling.
- Use only M3 UNC mounting screws.
- Do not overtighten the mounting screws (maximum torque: 4.0 inch-lb).
- Four (4) threads (0.080 inches) minimum screw engagement recommended.

Measurements shown in Figure 4 are in inches.

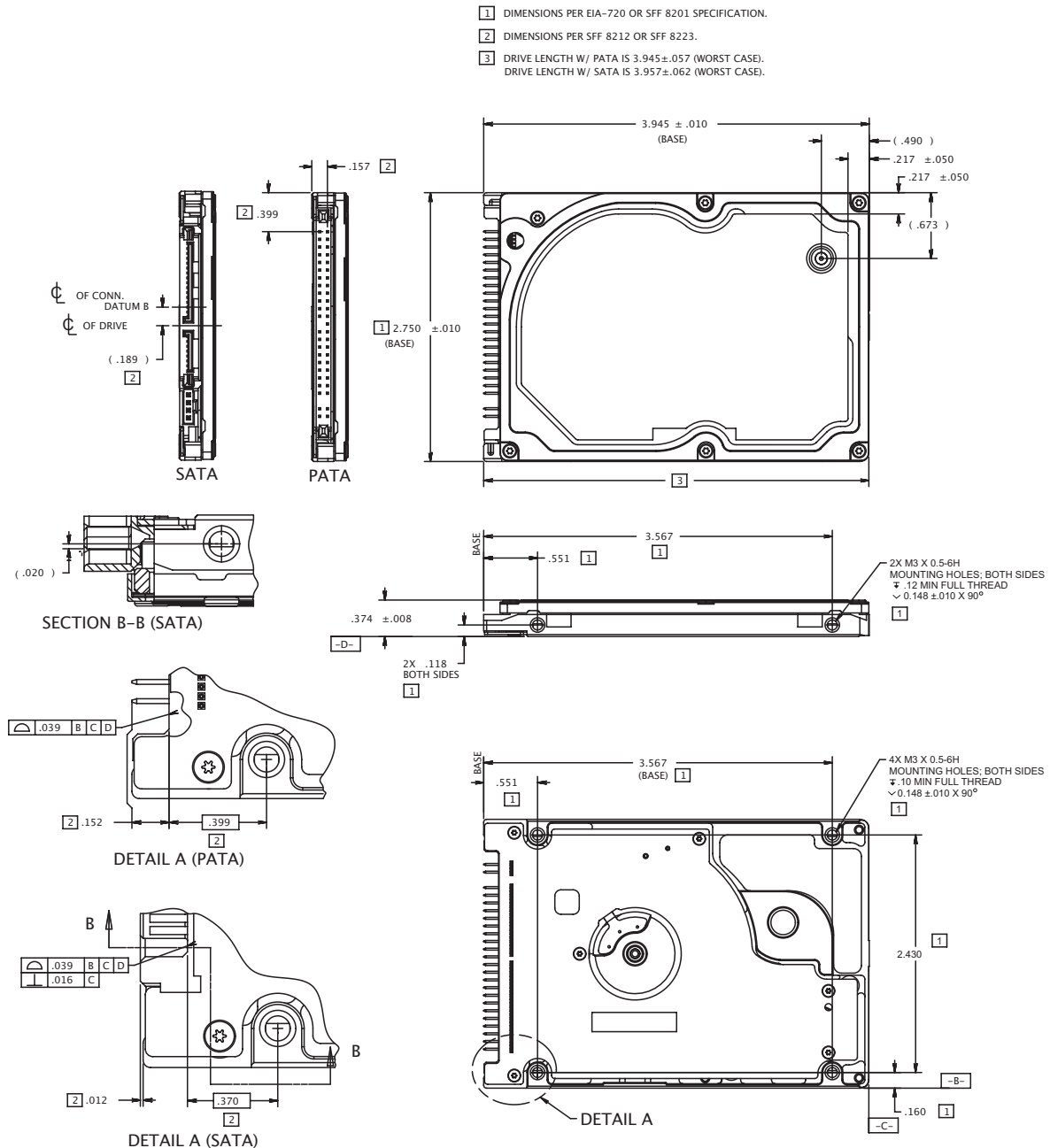

Figure 4. Mounting dimensions—top, side and end view

4.0 Serial ATA (SATA) interface

These drives use the industry-standard Serial ATA interface that supports FIS data transfers. It supports ATA programmed input/output (PIO) modes 0–4; multiword DMA modes 0–2, and Ultra DMA modes 0–6. The drive also supports the use of the IORDY signal to provide reliable high-speed data transfers.

For detailed information about the Serial ATA interface, refer to the “Serial ATA: High Speed Serialized AT Attachment” specification.

4.1 Hot-Plug compatibility

Momentum 5400.4 SATA drives incorporate connectors which enable you to hot plug these drives in accordance with the Serial ATA: High Speed Serialized AT Attachment specification revision 2.0. This specification can be downloaded from <http://www.serialata.org>. This device requires a COMRESET from the host after a hotplug event.

4.2 Serial ATA device plug connector pin definitions

Table 7 summarizes the signals on the Serial ATA interface and power connectors..

Table 7: Serial ATA connector pin definitions

Segment	Pin	Function	Definition
Signal	S1	Ground	2nd mate
	S2	A+	Differential signal pair A from Phy
	S3	A-	
	S4	Ground	2nd mate
	S5	B-	Differential signal pair B from Phy
	S6	B+	
	S7	Ground	2nd mate

Key and spacing separate signal and power segments

Table 7: Serial ATA connector pin definitions

Segment	Pin	Function	Definition
Power	P1	V ₃₃	3.3V power
	P2	V ₃₃	3.3V power
	P3	V ₃₃	3.3V power, pre-charge, 2nd mate
	P4	Ground	1st mate
	P5	Ground	2nd mate
	P6	Ground	2nd mate
	P7	V ₅	5V power, pre-charge, 2nd mate
	P8	V ₅	5V power
	P9	V ₅	5V power
	P10	Ground	2nd mate
	P11	Reserved	The pin corresponding to P11 in the backplane receptacle connector is also reserved The corresponding pin to be mated with P11 in the power cable receptacle connector shall always be grounded
	P12	Ground	1st mate.
	P13	V ₁₂	12V power, pre-charge, 2nd mate
	P14	V ₁₂	12V power
	P15	V ₁₂	12V power

Notes:

- All pins are in a single row, with a 1.27 mm (0.050") pitch.
- The comments on the mating sequence apply to the case of backplane blindmate connector only. In this case, the mating sequences are:
 - the ground pins P4 and P12.
 - the pre-charge power pins and the other ground pins.
 - the signal pins and the rest of the power pins.
- There are three power pins for each voltage. One pin from each voltage is used for pre-charge when installed in a blind-mate backplane configuration.
- All used voltage pins (V_x) must be terminated.

4.3 Supported ATA commands

The following table lists Serial ATA standard commands that the drive supports. For a detailed description of the ATA commands, refer to the Serial ATA: High Speed Serialized AT Attachment specification. See “S.M.A.R.T. commands” on page 30 for details and subcommands used in the S.M.A.R.T. implementation.

Command name	Command code (in hex)
ATA-standard commands	
Device Configuration Restore	B1h/C0h
Device Configuration Freeze Lock	B1h/C1h
Device Configuration Identify	B1h/C2h
Device Configuration Set	B1h/C3h
Download Microcode	92h
Execute Device Diagnostics	90h
Flush Cache	E7h
Flush Cache Extended	EAh
Identify Device	ECh
Initialize Device Parameters	91h
Read Buffer	E4h
Read DMA	C8h
Read DMA Extended	25h
Read DMA without Retries	C9h
Read Long with Retries	22h
Read Long without Retries	23h
Read Multiple	C4h
Read Multiple Extended	29h
Read Native Max Address	F8h
Read Native Max Address Extended	27h
Read Sectors	20h
Read Sectors Extended	24h
Read Sectors without Retries	21h
Read Verify Sectors	40h
Read Verify Sectors Extended	42h
Read Verify Sectors without Retries	41h
Seek	70h
Set Features	EFh
Set Max Address	F9h

Command name	Command code (in hex)	
Note: Individual Set Max commands are identified by the value placed in the Set Max Features register as defined to the right.	Address:	00 _H
	Password:	01 _H
	Lock:	02 _H
	Unlock:	03 _H
	Freeze Lock:	04 _H
Set Multiple Mode	C6h	
S.M.A.R.T. Disable Operations	B0h/D9h	
S.M.A.R.T. Enable/Disable Autosave	B0h/D2h	
S.M.A.R.T. Enable Operations	B0h/D8h	
S.M.A.R.T. Enable/Disable Auto Offline	B0h/DBh	
S.M.A.R.T. Enable One Attribute Modification	B0h/E0h	
S.M.A.R.T. Execute Offline	B0h/D4h	
S.M.A.R.T. Read Attribute Thresholds	B0h/D1h	
S.M.A.R.T. Read Data	B0h/D0h	
S.M.A.R.T. Read Log Sector	B0h/D5h	
S.M.A.R.T. Return Status	B0h/DAh	
S.M.A.R.T. Save Attribute Values	B0h/D3h	
S.M.A.R.T. Write Attribute Thresholds	B0h/D7h	
S.M.A.R.T. Write Attribute Values	B0h/E1h	
S.M.A.R.T. Write Log Sector	B0h/D6h	
Write Buffer	E8h	
Write DMA	CAh	
Write DMA Extended	35h	
Write DMA without Retries	CBh	
Write Long with Retries	32h	
Write Long without Retries	33h	
Write Multiple	C5h	
Write Sectors	30h, 31h	
Write Sectors Extended	34h	
ATA-standard power-management commands		
Check Power Mode	98h or E5h	
Idle	97h or E3h	
Idle Immediate	95h or E1h	
Sleep	99h or E6h	
Standby	96h or E2h	
Standby Immediate	94h or E0h	
ATA-standard security commands		

Command name	Command code (in hex)
Security Set Password	F1h
Security Unlock	F2h
Security Erase Prepare	F3h
Security Erase Unit	F4h
Security Freeze Lock	F5h
Security Disable Password	F6h

4.3.1 Identify Device command

The Identify Device command (command code EC_H) transfers information about the drive to the host following power up. The data is organized as a single 512-byte block of data, whose contents are shown in the table on page 27. All reserved bits or words should be set to zero. Parameters listed with an “x” are drive-specific or vary with the state of the drive. See Section 2.0 on page 3 for default parameter settings.

The following commands contain drive-specific features that may not be included in the Serial ATA specification.

Word	Description	Value
0	Configuration information: • Bit 15: 0 = ATA; 1 = ATAPI • Bit 7: removable media • Bit 6: removable controller • Bit 0: reserved	0C5A _H
1	Number of logical cylinders	16,383
2	ATA-reserved	0000 _H
3	Number of logical heads	16
4	Retired	0000 _H
5	Retired	0000 _H
6	Number of logical sectors per logical track: 63	003F _H
7–9	Retired	0000 _H
10–19	Serial number: (20 ASCII characters, 0000 _H = none)	ASCII
20	Retired	0000 _H
21	Retired	0400 _H
22	Obsolete	0000 _H
23–26	Firmware revision (8 ASCII character string, padded with blanks to end of string)	x.xx
27–46	Drive model number: (40 ASCII characters, padded with blanks to end of string)	ST9250827AS ST9200827AS ST9160827AS ST9120817AS
47	(Bits 7–0) Maximum sectors per interrupt on Read multiple and Write multiple (16)	8010 _H
48	Reserved	0000 _H
49	Standard Standby timer, IORDY supported and may be disabled	2F00 _H
50	ATA-reserved	0000 _H
51	PIO data-transfer cycle timing mode	0200 _H
52	Retired	0200 _H
53	Words 54–58, 64–70 and 88 are valid	0007 _H
54	Number of current logical cylinders	xxxx _H
55	Number of current logical heads	xxxx _H
56	Number of current logical sectors per logical track	xxxx _H

Word	Description	Value
57–58	Current capacity in sectors	xxxx _H
59	Number of sectors transferred during a Read Multiple or Write Multiple command	xxxx _H
60–61	Total number of user-addressable LBA sectors available (see Section 2.2 for related information)	ST9250827AS = 488,397,168 ST9200827AS = 390,721,968 ST9160827AS = 312,581,808 ST9120817AS = 234,441,648
62	Retired	0000 _H
63	Multiword DMA active and modes supported (see note following this table)	xx07 _H
64	Advanced PIO modes supported (modes 3 and 4 supported)	0003 _H
65	Minimum multiword DMA transfer cycle time per word (120 nsec)	0078 _H
66	Recommended multiword DMA transfer cycle time per word (120 nsec)	0078 _H
67	Minimum PIO cycle time without IORDY flow control (240 nsec)	00F0 _H
68	Minimum PIO cycle time with IORDY flow control (120 nsec)	0078 _H
69–74	ATA-reserved	0000 _H
75	Queue depth	0000 _H
76	Serial ATA capabilities	0508 _H
77	ATA-reserved	0000 _H
78	Serial ATA features supported	0048 _H
79	Serial ATA features enabled	0040 _H
80	Major version number	003E _H
81	Minor version number	0000 _H
82	Command sets supported	306B _H
83	Command sets supported	4001 _H
84	Command sets support extension	4000 _H
85	Command sets enabled	30xx _H
86	Command sets enabled	0001 _H
87	Command sets enable extension	4000 _H
88	Ultra DMA support and current mode (see note following this table)	xx7F _H
89	Security erase time	0000 _H
90	Enhanced security erase time	0000 _H
92	Master password revision code	FFFE _H
93	Hardware reset value (see description following this table)	xxxx _H
94	Auto acoustic management setting	xxxx _H

Word	Description	Value
95–99	ATA-reserved	0000 _H
100–103	Total number of user-addressable LBA sectors available (see Section 2.2 for related information) These words are required for drives that support the 48-bit addressing feature. Maximum value: 0000FFFFFFFF _H .	ST9250827AS = 488,397,168 ST9200827AS = 390,721,968 ST9160827AS = 312,581,808 ST9120817AS = 234,441,648
104–127	ATA-reserved	0000 _H
128	Security status	0001 _H
129–159	Seagate-reserved	xxxx _H
160–254	ATA-reserved	0000 _H
255	Integrity word	xxA5 _H

Note. See the bit descriptions below for words 63, 88, 93 and 94 of the Identify Drive data:

Description (if bit is set to 1)

Bit	Word 63
0	Multiword DMA mode 0 is supported.
1	Multiword DMA mode 1 is supported.
2	Multiword DMA mode 2 is supported.
8	Multiword DMA mode 0 is currently active.
9	Multiword DMA mode 1 is currently active.
10	Multiword DMA mode 2 is currently active.
Bit	Word 88
0	Ultra DMA mode 0 is supported.
1	Ultra DMA mode 1 is supported.
2	Ultra DMA mode 2 is supported.
3	Ultra DMA mode 3 is supported.
4	Ultra DMA mode 4 is supported.
8	Ultra DMA mode 0 is currently active.
9	Ultra DMA mode 1 is currently active.
10	Ultra DMA mode 2 is currently active.
11	Ultra DMA mode 3 is currently active.
12	Ultra DMA mode 4 is currently active.
13	Ultra DMA mode 5 is currently active.
Bit	Word 93
13	1 = 80-conductor cable detected, CBLID above V _{IH} 0 = 40-conductor cable detected, CBLID below V _{IL}

4.3.2 Set Features command

This command controls the implementation of various features that the drive supports. When the drive receives this command, it sets BSY, checks the contents of the Features register, clears BSY and generates an interrupt. If the value in the register does not represent a feature that the drive supports, the command is aborted. Power-on default has the read look-ahead and write caching features enabled. The acceptable values for the Features register are defined as follows:

Table 8: Set Features command values

02 _H	Enable write cache (<i>default</i>).
03 _H	Set transfer mode (based on value in Sector Count register). Sector Count register values:
00 _H	Set PIO mode to default (PIO mode 2).
01 _H	Set PIO mode to default and disable IORDY (PIO mode 2).
08 _H	PIO mode 0
09 _H	PIO mode 1
0A _H	PIO mode 2
0B _H	PIO mode 3
0C _H	PIO mode 4 (<i>default</i>)
20 _H	Multiword DMA mode 0
21 _H	Multiword DMA mode 1
22 _H	Multiword DMA mode 2
40 _H	Ultra DMA mode 0
41 _H	Ultra DMA mode 1
42 _H	Ultra DMA mode 2
43 _H	Ultra DMA mode 3
44 _H	Ultra DMA mode 4
45 _H	Ultra DMA mode 5
55 _H	Disable read look-ahead (read cache) feature.
82 _H	Disable write cache
AA _H	Enable read look-ahead (read cache) feature (<i>default</i>).
F1 _H	Report full capacity available

Note. At power-on, or after a hardware or software reset, the default values of the features are as indicated above.

4.3.3 S.M.A.R.T. commands

S.M.A.R.T. provides near-term failure prediction for disc drives. When S.M.A.R.T. is enabled, the drive monitors predetermined drive attributes that are susceptible to degradation over time. If self-monitoring determines that a failure is likely, S.M.A.R.T. makes a status report available to the host. Not all failures are predictable. S.M.A.R.T. predictability is limited to the attributes the drive can monitor. For more information on S.M.A.R.T. commands and implementation, see the *Draft ATA-5 Standard*.

SeaTools diagnostic software activates a built-in drive self-test (DST S.M.A.R.T. command for D4_H) that eliminates unnecessary drive returns. The diagnostic software ships with all new drives and is also available at: <http://seatools.seagate.com>.

This drive is shipped with S.M.A.R.T. features disabled. You must have a recent BIOS or software package that supports S.M.A.R.T. to enable this feature. The table below shows the S.M.A.R.T. command codes that the drive uses.

Table 9: S.M.A.R.T. commands

Code in features register	S.M.A.R.T. command
D0 _H	S.M.A.R.T. Read Data
D1 _H	Vendor-specific
D2 _H	S.M.A.R.T. Enable/Disable Attribute Autosave
D3 _H	S.M.A.R.T. Save Attribute Values
D4 _H	S.M.A.R.T. Execute Off-line Immediate (runs DST)
D5 _H	S.M.A.R.T. Read Log Sector
D6 _H	S.M.A.R.T. Write Log Sector
D7 _H	Vendor-specific
D8 _H	S.M.A.R.T. Enable Operations
D9 _H	S.M.A.R.T. Disable Operations
DA _H	S.M.A.R.T. Return Status

Note. If an appropriate code is not written to the Features Register, the command is aborted and 0x04 (abort) is written to the Error register.

5.0 Seagate Technology support services

Internet

For information regarding Seagate products and services, visit www.seagate.com. Worldwide support is available 24 hours daily by email for your questions.

Presales Support:

Presales@Seagate.com

Technical Support:

DiscSupport@Seagate.com

Warranty Support:

<http://www.seagate.com/support/service/index.html>

mySeagate

my.seagate.com is the industry's first Web portal designed specifically for OEMs and distributors. It provides self-service access to critical applications, personalized content and the tools that allow our partners to manage their Seagate account functions. Submit pricing requests, orders and returns through a single, password-protected Web interface-anytime, anywhere in the world.

spp.seagate.com

spp.seagate.com supports Seagate resellers with product information, program benefits and sales tools. You may register for customized communications that are not available on the web. These communications contain product launch, EOL, pricing, promotions and other channel-related information. To learn more about the benefits or to register, go to spp.seagate.com, any time, from anywhere in the world.

Seagate Service Centers

Presales Support

Our Presales Support staff can help you determine which Seagate products are best suited for your specific application or computer system, as well as product availability and compatibility.

Technical Support

Seagate technical support is available to assist you online at support.seagate.com or through one of our call centers. Have your system configuration information and your "ST" model number available.

SeaTDD™ (+1-405-324-3655) is a telecommunications device for the deaf (TDD). You can send questions or comments 24 hours daily and exchange messages with a technical support specialist during normal business hours for the call center in your region.

Customer Service Operations

Warranty Service

Seagate offers worldwide customer support for Seagate products. Seagate distributors, OEMs and other direct customers should contact their Seagate Customer Service Operations (CSO) representative for warranty-related issues. Resellers or end users of drive products should contact their place of purchase or Seagate warranty service for assistance. Have your serial number and model or part number available.

Data Recovery Services

Seagate offers data recovery services for all formats and all brands of storage media. Our data recovery services labs are currently located throughout the world. . Additional information, including an online request form and data loss prevention resources, is available at <http://services.seagate.com/index.aspx>

Authorized Service Centers

Seagate Service Centers are available on a global basis for the return of defective products. Contact your customer support representative for the location nearest you.

USA/Canada/Latin America support services

For an extensive list of telephone numbers to technical support, presales and warranty service in USA/Canada/Latin America, including business hours, go to the "Contact Us" page on www.seagate.com.

Global Customer Support

Presales, Technical, and Warranty Support

Call Center	Toll-free	Direct dial
USA, Canada, and Mexico	1-800-SEAGATE	+1-405-324-4700

Data Recovery Services

Call Center	Toll-free	Direct dial	FAX
USA, Canada, and Mexico	1-800-475-01435	+1-905-474-2162	1-800-475-0158 +1-905-474-2459

Europe, the Middle East and Africa Support Services

For an extensive list of telephone numbers to technical support, presales and warranty service in Europe, the Middle East and Africa, go to the "Contact Us" page on www.seagate.com.

Asia/Pacific Support Services

For an extensive list of telephone numbers to technical support, presales and warranty service in Asia/Pacific, go to the "Contact Us" page on www.seagate.com.

Index

A

- ACA 15
- acoustics 4, 13
- Active mode 10
- Address 23
- AFR 14
- Agency certification 14
- Altitude 11
- Altitude, nonoperating 4
- Altitude, operating 4
- Ambient temperature 4, 11
- ambient temperature 7
- Annualized Failure Rate 14
- Annualized Failure Rate (AFR) 4
- Areal density 3, 6
- areal density 1
- ATA commands 23
- ATA data-transfer modes supported 3
- Australia/New Zealand Standard AS/NZS3548 1995 15
- Australian Communication Authority (ACA) 15
- Australian C-Tick 15
- Average seek time 7
- Average seek, read 3
- Average seek, write 3

B

- bels 4
- BPI 3
- buffer 3, 6
- Bytes per sector 3, 5

C

- cables and connectors 18
- Cache 3
- cache 6
- capacity 5
- case temperature 11
- CE mark 14
- certification 14
- Check Power Mode 24
- chemical substances 16
- Class B computing device 15
- compatibility 14
- Conducted noise 9
- Conducted RF immunity 13
- Configuring the drive 17
- connectors 18
- CSA C22.2 (950) 14
- current 4
- cycles 14

- Cylinders 5

D

- data-transfer rates 1
- DC power 8
- Default logical geometry 5
- density 3
- Device Configuration Freeze Lock 23
- Device Configuration Restore 23
- Device Configuration Set 23
- Diagnostics 23
- dimensions 19
- Discs 3
- dissipation 8
- Download Microcode 23

E

- Electrical fast transient 13
- Electromagnetic compatibility 14
- Electromagnetic Compatibility Directive (89/336/EEC) 14
- Electromagnetic immunity 13
- Electrostatic discharge 13
- electrostatic discharge (ESD) 17
- EN 55022, Class B 14
- EN 55024 14
- EN 60950 14
- Environmental protection 16
- Environmental specifications 11
- error-correction algorithms 1
- errors 4, 14
- ESD 17
- EU 14
- European Union (EU) requirements 14
- European Union Restriction of Hazardous Substances 16
- evice Configuration Identify 23
- Execute Device Diagnostics 23

F

- FCC verification 15
- features 1
- Federal Communications Commission 15
- Flush Cache 23
- Flush Cache Extended 23
- Formatted capacity 5
- Formatted Gbytes 3
- Freeze Lock 23

G

- Gbytes 5
- geometry 5
- gradient 4

Guaranteed sectors 3, 5
guaranteed sectors 5

H

handling 17
Handling precautions 17
heads 5
Height 3
height 6
Humidity 11
humidity 4

I

I/O data-transfer rate 3, 6
Identify 23
Identify Device 23
Identify Device command 26
Idle 8, 24
Idle and Standby timers 10
Idle Immediate 24
Idle mode 4, 10
Idle mode power 8
IEC950 14
Information Technology Equipment (ITE) 14
Initialize Device Parameters 23
Input noise ripple 9
Interface 6
interface 21
Interleave 6
Internal data-transfer rate 6
ITE 14

K

Korean RRL 15

L

latency 3
LBA mode 5
Length 3
length 6
Load/Unload 14
logical geometry 5

M

master/slave 2
Max Address 23
Microcode 23
mounting 19
mounting screws 12
mounting the drive 17

N

noise 9
nominal power 7
Nonoperating shock 12
Nonoperating vibration 12
Nonrecoverable read errors 4
nonrecoverable read errors 14

O

Operating shock 12
Operating vibration 12

P

Physical characteristics 6
Physical organization 6
Physical read/write heads 3
point-to-point 2, 18
Power consumption 8
power dissipation 8
power management 10
power on/off cycles 14
Power specifications 8
Power-management modes 10
Power-on to Ready 7
Power-on to ready 3
precautions 17, 19
programmable power management 10

Q

quick reference 3

R

Radiated RF immunity 13
Radio and television interference 15
radio frequency (RF) 13
random track location 8
Read Buffer 23
Read DMA 23
Read DMA Extended 23
Read DMA without Retries 23
read errors 4, 14
Read Long with Retries 23
Read Long without Retries 23
Read Multiple 23
Read Multiple Extended 23
Read Native Max Address 23
Read Native Max Address Extended 23
Read Sectors 23
Read Sectors Extended 23
Read Sectors without Retries 23
Read Verify Sectors 23
Read Verify Sectors Extended 23
Read Verify Sectors without Retries 23

- Read/write heads 5
- Read/write power 4
- read/write power and current 8
- Recording density 3, 6
- Recording method 6
- Recording technology 6
- Relative humidity 4, 11
- Reliability 14
- resistance 9
- Retries 23
- RF 13
- RoHS 16
- RPM 3
- RRL 15

S

- S.M.A.R.T. 24
- S.M.A.R.T. implementation 23
- Safety certification 14
- SATA 6, 21
- screws 12, 19
- sector 5
- sectors 5
- Sectors per track 5
- Security Disable Password 25
- Security Erase Prepare 25
- Security Erase Unit 25
- Security Freeze Lock 25
- Security Set Password 25
- Security Unlock 25
- Seek 23
- seek mode 8
- Seek power 4
- Seek time 7
- seek time 3
- Seeking 8
- Self refresh, low power 10
- Serial ATA 6
- Serial ATA (SATA) interface 21
- serial ATA ports 2
- servo electronics 8
- Set Features 23
- Set Max Address 23
- Set Multiple Mode 24
- Shock 12
- Shock, nonoperating 4
- Shock, operating 4
- single-track seeks 7
- Sleep 8, 24
- Sleep mode 4, 10
- sound power 4
- Specification summary table 3
- Spindle speed 3, 6
- Spinup 8
- spinup power 8

- Standby 8, 24
- Standby Immediate 24
- Standby mode 4, 8, 10
- Standby to Ready 7
- Standby to ready 3
- Start/stop times 7
- Startup current 4
- static-discharge 17
- support services 31
- Surge immunity 13
- sustained transfer rate 6

T

- technical support services 31
- temperature 4, 7, 11
- Temperature gradient 4, 11
- timers 10
- TPI 3
- Track density 3, 6
- Track-to-track seek time 3, 7
- transfer rate 3, 6
- TUV North America 14

U

- UL 1950 14

V

- Vibration 12
- Vibration, nonoperating 4
- Vibration, operating 4
- Voltage dips, interrupts 13
- Voltage tolerance 4, 9

W

- Warranty 14
- Weight 3
- weight 6
- Wet bulb temperature 4, 11
- Width 3
- width 6
- Write Buffer 24
- Write DMA 24
- Write DMA Extended 24
- Write Long with Retries 24
- Write Long without Retries 24
- Write Multiple 24
- Write Sectors 24



Seagate Technology LLC
920 Disc Drive, Scotts Valley, California 95066-4544, USA
Publication Number: 100468842, Rev. A, Printed in USA