

A decorative graphic on the left side of the page. It features a solid blue circle at the top, a dashed circle below it, and a series of overlapping, semi-transparent blue circles and curved lines that create a sense of motion or depth. A horizontal dashed line runs across the page, passing through the middle of the graphic.

Product Manual

Momentum[®] SATA

ST9640320AS
ST9320310AS
ST9160316AS

100589392
Rev. B
December 2009

Revision history

Revision	Date	Sheets affected or comments
Rev. A	10/14/09	Initial release.
Rev. B	12/01/09	fc, 1, 3-6, 10-12 & 24..

Copyright © 2009 Seagate Technology LLC. All rights reserved. Printed in U.S.A.

Publication number: 100589392, Rev. B, December 2009

Seagate, Seagate Technology and the Wave logo are registered trademarks of Seagate Technology LLC in the United States and/or other countries. Momentus, SeaTools and SeaTDD are either trademarks or registered trademarks of Seagate Technology LLC or one of its affiliated companies in the United States and/or other countries. All other trademarks or registered trademarks are the property of their respective owners. No part of this publication may be reproduced in any form without the written permission of Seagate Technology LLC.

One gigabyte, or GB, equals one billion bytes and one terabyte, or TB, equals one trillion bytes. Your computer's operating system may use a different standard of measurement and report a lower capacity. In addition, some of the listed capacity is used for formatting and other functions, and thus will not be available for data storage. Seagate reserves the right to change, without notice, product offerings or specifications.

Contents

1.0	Introduction	1
1.1	About the Serial ATA interface	2
2.0	Drive specifications	3
2.1	Specification summary table	3
2.2	Formatted capacity	5
2.2.1	LBA mode	5
2.3	Default logical geometry	5
2.4	Physical organization	5
2.5	Recording and interface technology	6
2.6	Physical characteristics	6
2.7	Seek time	6
2.8	Start/stop times	7
2.9	Power specifications	7
2.9.1	Power consumption	7
2.9.2	Deferred spinup	8
2.9.3	Conducted noise	8
2.9.4	Voltage tolerance	8
2.9.5	Power-management modes	9
2.10	Environmental specifications	10
2.10.1	Ambient temperature	10
2.10.2	Temperature gradient	10
2.10.3	Humidity	10
2.10.4	Altitude	10
2.10.5	Shock	11
2.10.6	Vibration	11
2.11	Acoustics	12
2.12	Electromagnetic immunity	12
2.13	Reliability	13
2.14	Agency certification	13
2.14.1	Safety certification	13
2.14.2	Electromagnetic compatibility	13
2.14.3	FCC verification	14
2.15	Environmental protection	15
2.15.1	European Union Restriction of Hazardous Substances (RoHS)	15
2.15.2	China Restriction of Hazardous Substances (RoHS) Directive	15
2.16	Corrosive environment	15
3.0	Configuring and mounting the drive	16
3.1	Handling and static-discharge precautions	16
3.2	Configuring the drive	17
3.3	Serial ATA cables and connectors	17
3.4	Drive mounting	18
4.0	Serial ATA (SATA) interface	20
4.1	Hot-Plug compatibility	20
4.2	Serial ATA device plug connector pin definitions	20
4.3	Supported ATA commands	22
4.3.1	Identify Device command	24
4.3.2	Set Features command	27
4.3.3	S.M.A.R.T. commands	28
5.0	Seagate Technology support services	29

List of Figures

Figure 1.	Typical +5V only startup and operation current profile	8
Figure 2.	Serial ATA connectors	17
Figure 3.	Attaching SATA cabling	17
Figure 4.	Mounting dimensions—top, side and end view	19

1.0 Introduction

This manual describes the functional, mechanical and interface specifications for the following Seagate Momentus® SATA model drives:

- **ST9640320AS**
- **ST9320310AS**
- **ST9160316AS**

These drives provide the following key features:

- 5400-RPM spindle speed.
- 8-Mbyte buffer.
- Quiet operation. Fluid Dynamic Bearing (FDB) motor.
- High instantaneous (burst) data-transfer rates (up to 3.0 Gbits/sec).
- Perpendicular recording technology provides the drives with increased areal density.
- State-of-the-art cache and on-the-fly error-correction algorithms.
- Native Command Queuing (NCQ) with command ordering.
- Full-track multiple-sector transfer capability without local processor intervention.
- 1000 Gs nonoperating shock and 350 Gs of operating shock.
- SeaTools diagnostic software performs a drive self-test that eliminates unnecessary drive returns.
- The 3D Defense System™, which includes Drive Defense, Data Defense and Diagnostic Defense, offers the industry's most comprehensive protection for disc drives.
- Support for S.M.A.R.T. drive monitoring and reporting.
- Support for Read Multiple and Write Multiple commands.

1.1 About the Serial ATA interface

The Serial ATA interface provides several advantages over the traditional (parallel) ATA interface. The primary advantages include:

- Easy installation and configuration with true plug-and-play connectivity. It is not normally necessary to set any jumpers or other configuration options.
- Thinner and more flexible cabling for improved enclosure airflow and ease of installation.
- Scalability to higher performance levels.

In addition, Serial ATA makes the transition from parallel ATA easy by providing legacy software support. Serial ATA was designed to allow you to install a Serial ATA host adapter and Serial ATA disc drive in your current system and expect all of your existing applications to work as normal.

The Serial ATA interface connects each disc drive in a point-to-point configuration with the Serial ATA host adapter. There is no master/slave relationship with Serial ATA devices like there is with parallel ATA. If two drives are attached on one Serial ATA host adapter, the host operating system views the two devices as if they were both “masters” on two separate ports. This essentially means both drives behave as if they are Device 0 (master) devices.

Note. The host adapter may, optionally, emulate a master/slave environment to host software where two devices on separate Serial ATA ports are represented to host software as a Device 0 (master) and Device 1 (slave) accessed at the same set of host bus addresses. A host adapter that emulates a master/slave environment manages two sets of shadow registers. This is not a typical Serial ATA environment.

The Serial ATA host adapter and drive share the function of emulating parallel ATA device behavior to provide backward compatibility with existing host systems and software. The Command and Control Block registers, PIO and DMA data transfers, resets, and interrupts are all emulated.

The Serial ATA host adapter contains a set of registers that shadow the contents of the traditional device registers, referred to as the Shadow Register Block. All Serial ATA devices behave like Device 0 devices. For additional information about how Serial ATA emulates parallel ATA, refer to the “Serial ATA: High Speed Serialized AT Attachment” specification. The specification can be downloaded from <http://www.serialata.org>.

2.0 Drive specifications

Unless otherwise noted, all specifications are measured under ambient conditions, at 25°C, and nominal power. For convenience, the phrases *the drive* and *this drive* are used throughout this manual to indicate the Momentus SATA models.

2.1 Specification summary table

The specifications listed in this table are for quick reference. For details on specification measurement or definition, see the appropriate section of this manual.

Table 1: Drive specifications for 640, 320 and 160GB models

Drive specification	ST9640320AS	ST9320310AS	ST9160316AS
Formatted GB (512 bytes/sector)*	640	320	160
guaranteed logical blocks	1,250,263,728	625,142,448	312,581,808
bytes per physical sector	512		
Physical read/write heads	4	2	1
Discs	2	1	
Cache (MB)	8		
Recording density in BPI (bits/inch avg)	1,560k		
Track density TPI (tracks/inch avg)	325k		
Areal density (Gbits/inch ² avg)	507		
Spindle speed (RPM)	5400		
Average latency (ms)	5.5		
Internal transfer rate (Mb/s max)	1,175		
I/O data transfer rate (MB/s max)	300		
ATA data-transfer modes supported	SATA 1.0, Serial ATA Revision 2.6 PIO modes 0–4 Multiword DMA modes 0–2 Ultra DMA modes 0–6		
Height (max)	9.5 +/- 0.2 mm (0.374 +/- .008in)		
Width (max)	69.85 mm +/- 0.25 mm (2.75 +/- 0.010in)		
Length (max)	100.35 + 0.20 / - 0.25 mm (3.951 + 0.008 / - 0.010in)		
Weight (max)	<100 g (0.220 lb)		
Power-on to ready (sec typical)	3.5		
Power-on to ready (sec max)	4.5		
Standby to ready (sec typical)	2.5		
Standby to ready (sec max)	3.5		
Track-to-track seek time, read (ms typical)	1.5		
Average seek, read (ms typical)	11.0		
Full-stroke seek, read (ms max)	27.0		
Startup current, +5V (max)	1.0A		

Table 1: Drive specifications for 640, 320 and 160GB models

Drive specification	ST9640320AS	ST9320310AS	ST9160316AS
Seek power (typical)	1.3W		
Read/write power (typical)	Read: 1.25W; Write: 1.65W		
Idle mode, low power (typical)	0.68W		
Standby mode	0.12W (typical)***		
Sleep mode	0.12W (typical)***		
Voltage tolerance (including noise)	+5V ± 5%		
Ambient temperature	0° to 60°C (operating), -40° to 70°C (nonoperating)		
Temperature gradient (°C per hour max)	20°C (operating) 35°C (nonoperating)		
Relative humidity	5% to 95% (operating) 5% to 95% (nonoperating)		
Relative humidity gradient	30% per hour max		
Wet bulb temperature (°C max)	37.7 (operating) 40 (nonoperating)		
Altitude, operating	-304.8 m to 3,048 m (-1000 ft to 10,000 ft)		
Altitude, nonoperating (meters below mean sea level, max)	-304.8 m to 12,192 m (-1000 ft to 40,000 ft)		
Shock, operating (Gs max at 2ms)	350		
Shock, nonoperating (Gs max at 1ms)	1000		
Shock, nonoperating (Gs max at 0.5ms)	1000		
Vibration, operating	1.0 G (0 to peak, 5–500 Hz)		
Vibration, nonoperating	5.0 Gs (0 to peak, 5–500 Hz)		
Drive acoustics, sound power (bels)			
Idle**	2.4 (typical) 2.6 (max)		
Seek	2.6 (typical) 2.7 (max)		
Nonrecoverable read errors	1 per 10 ¹⁴ bits read		
Annualized Failure Rate (AFR)	0.48%		
Load/Unload (U/UL) cycles			
25°C, 50% relative humidity	600,000 software-controlled power on/off cycles 50,000 hard power on/off cycles		
32°C, 80% relative humidity 5°C, 80% relative humidity 5°C, 10% relative humidity 55°C, 16% relative humidity	600,000 software-controlled power on/off cycles 50,000 hard power on/off cycles		
Warranty	To determine the warranty for a specific drive, use a web browser to access the following web page: support.seagate.com/customer/warranty_validation.jsp You will be asked to provide the drive serial number, model number (or part number) and country of purchase. After submitting this information, the system will display the warranty information for your drive.		
Supports Hotplug operation per Serial ATA Revision 2.6 specification	Yes (requires COMRESET from host after a hotplug event)		

*One Gbyte equals one billion bytes when referring to hard drive capacity. Accessible capacity may vary depending on operating environment and formatting.

**During periods of drive idle, some offline activity may occur according to the S.M.A.R.T. specification, which may increase acoustic and power to operational levels.

***Typical notebooks will pull power to the drive when entering S3 and S4; while in the S3 and S4 states, drive sleep and drive standby modes will not contribute to battery power consumption.

2.2 Formatted capacity

Model	Formatted capacity*	Guaranteed logical blocks	Bytes per physical sector
ST9640320AS	640GB	1,250,263,728	512
ST9320310AS	320GB	625,142,448	
ST9160316AS	160GB	312,581,808	

*One Gbyte equals one billion bytes when referring to hard drive capacity. Accessible capacity may vary depending on operating environment and formatting.

2.2.1 LBA mode

When addressing these drives in LBA mode, all blocks (sectors) are consecutively numbered from 0 to $n-1$, where n is the number of guaranteed logical blocks as defined above.

See Section 4.3.1, "Identify Device command" (words 60-61 and 100-103) for additional information about 48-bit addressing support of drives with capacities over 137GB.

2.3 Default logical geometry

Cylinders	Read/write heads	Sectors per track
16,383	16	63

LBA mode

When addressing these drives in LBA mode, all blocks (sectors) are consecutively numbered from 0 to $n-1$, where n is the number of guaranteed logical blocks as defined above.

2.4 Physical organization

Drive model	Read/write heads	Number of discs
ST9640320AS and ST9640320ASG	4	2
ST9320310AS and ST9320310ASG	2	1
ST9160316AS and ST9160316ASG	1	1

2.5 Recording and interface technology

Interface	Serial ATA (SATA)
Recording method	Perpendicular
Recording density BPI (bits/inch avg)	1560k
Track density TPI (tracks/inch avg)	325k
Areal density (Gbits/inch ² avg)	507
Spindle speed (RPM) ($\pm 0.2\%$)	5400
Maximum Internal transfer rate (Mb/s)	1175
I/O data-transfer rate (MB/s max)	300
Interleave	1:1
Cache buffer	8MB (8192KB)

2.6 Physical characteristics

Drive specification		
Height	(mm) (in)	9.5 +/-0.2 0.374 +/-0.008
Width	(mm) (in)	69.85 +/-0.25 2.75 +/-0.010
Length	(mm) (in)	100.35 +0.20 / -0.25 3.951 +0.008 / -0.010
Weight (max)		<100 g 0.220 lb

2.7 Seek time

Seek measurements are taken with nominal power at 25°C ambient temperature. All times are measured using drive diagnostics. The specifications in the table below are defined as follows:

- Track-to-track seek time is an average of all possible single-track seeks in both directions.
- Average seek time is a true statistical random average of at least 5000 measurements of seeks between random tracks, less overhead.

Table 2: Typical seek times

Seek times (ms)	Read
Track-to-track (typical)	1.5
Average (typical)	11.0
Full-stroke (max)	27.0
Average latency	5.5

Note. These drives are designed to consistently meet the seek times represented in this manual. Physical seeks, regardless of mode (such as track-to-track and average), are expected to meet the noted values. However, due to the manner in which these drives are formatted, benchmark tests that include command overhead or measure logical seeks may produce results that vary from these specifications.

2.8 Start/stop times

Time to ready	Typical	Max @ 25°C
Power-on to Ready (sec)	3.5	4.5
Standby to Ready (sec)	2.5	3.5

2.9 Power specifications

The drive receives DC power (+5V) through a native SATA power connector.

2.9.1 Power consumption

Power requirements for the drives are listed in the table on page 7. Typical power measurements are based on an average of drives tested, under nominal conditions, at 25°C ambient temperature.

- **Spinup power**

Spinup power is measured from the time of power-on to the time that the drive spindle reaches operating speed.

- **Seek mode**

During seek mode, the read/write actuator arm moves toward a specific position on the disc surface and does not execute a read or write operation. Servo electronics are active. Seek mode power is measured based on three random seek operations every 100ms. This mode is not typical.

- **Read/write power and current**

Read/write power is measured with the heads on track, based on three 63 sector read or write operations every 100ms.

- **Idle mode power**

Idle mode power is measured with the drive up to speed, with servo electronics active and with the heads in a random track location.

- **Standby mode**

During Standby mode, the drive accepts commands, but the drive is not spinning, and the servo and read/write electronics are in power-down model

Table 3: DC power

Power dissipation	+5V input average (25° C)
Spinup (max)	1A
Seek	1.3W
Read	1.25W
Write	1.65W
Idle, performance*	1.10W
Idle, active*	0.68W
Idle, low power mode*	0.47W
Standby**	0.12W
Sleep	0.12W

*During periods of drive idle, some offline activity may occur according to the S.M.A.R.T. specification, which may increase acoustic and power to operational levels.

**Standby power is measured at steady state (after 200ms from transition)

2.9.1.1 Typical current profile

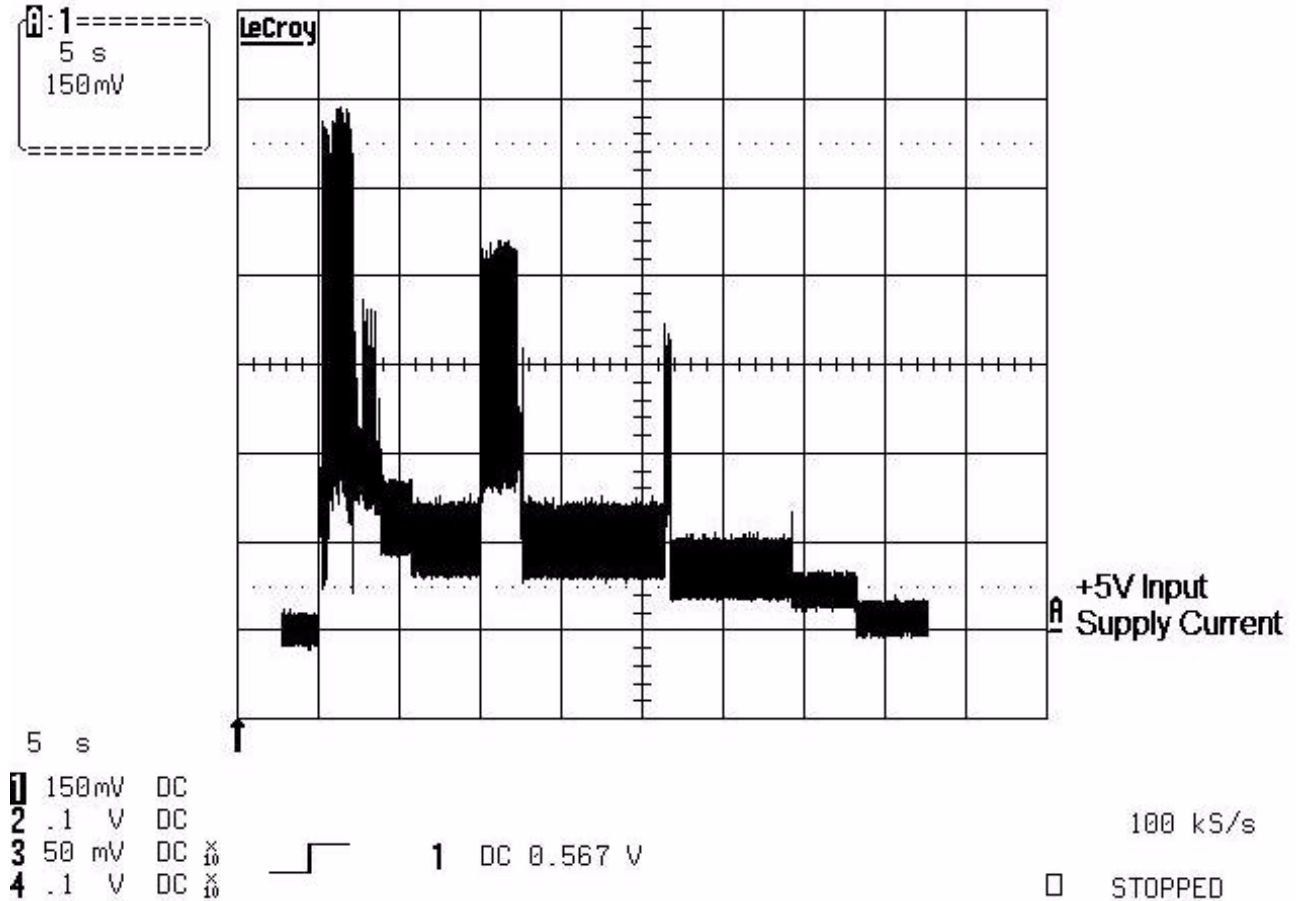

Figure 1. Typical +5V only startup and operation current profile

2.9.2 Deferred spinup

Momentum SATA drives do not support the deferred spinup option. If you require this option, refer to the Momentum 5400.3 SATA Blade Server family of drives.

2.9.3 Conducted noise

Input noise ripple is measured at the host system power supply across an equivalent 15-ohm resistive load on the +5V line.

Using 5V power, the drive is expected to operate with a maximum of 100 mV peak-to-peak square-wave injected noise at up to 10 MHz.

Note. Equivalent resistance is calculated by dividing the nominal voltage by the typical RMS read/write current.

2.9.4 Voltage tolerance

Voltage tolerance (including noise):

5V \pm 5%

2.9.5 Power-management modes

The drive provides programmable power management to provide greater energy efficiency. In most systems, you can control power management through the system setup program. The drive features the following power-management modes:

Table 4: Power management modes

Power modes	Heads	Spindle	Buffer
Active (operating)	Tracking	Rotating	Full power
Idle, performance	Tracking	Rotating	Self refresh—low power
Idle, active	Floating	Rotating	Self refresh—low power
Idle, low power	Parked	Rotating	Self refresh—low power
Standby	Parked	Stopped	Self refresh—low power
Sleep	Parked	Stopped	Self refresh—low power

- **Active mode**

The drive is in Active mode during the read/write and seek operations.

- **Idle mode**

The buffer remains enabled, and the drive accepts all commands and returns to Active mode any time disc access is necessary.

- **Standby mode**

The drive enters Standby mode when the host sends a Standby Immediate command. If the host has set the standby timer, the drive can also enter Standby mode automatically after the drive has been inactive for a specifiable length of time. The standby timer delay is established using a Standby or Idle command. In Standby mode, the drive buffer is in Self Refresh Low Power mode, the heads are parked and the spindle is at rest. The drive accepts all commands and returns to Active mode any time disc access is necessary.

- **Sleep mode**

The drive enters Sleep mode after receiving a Sleep command from the host. In Sleep mode, the drive buffer is in Self Refresh Low Power mode, the heads are parked and the spindle is at rest. The drive leaves Sleep mode after it receives a Hard Reset or Soft Reset from the host. After receiving a reset, the drive exits Sleep mode and enters Standby mode with all current translation parameters intact.

- **Idle and Standby timers**

Each time the drive performs an Active function (read, write or seek), the standby timer is reinitialized and begins counting down from its specified delay times to zero. If the standby timer reaches zero before any drive activity is required, the drive makes a transition to Standby mode. In both Idle and Standby mode, the drive accepts all commands and returns to Active mode when disc access is necessary.

2.10 Environmental specifications

2.10.1 Ambient temperature

Ambient temperature is defined as the temperature of the environment immediately surrounding the drive.

Above 1000 feet (305 meters), the maximum temperature is derated linearly by 1°C every 1000 feet.

Operating:	0° to 60°C (32° to 140°F)
Nonoperating:	−40° to 70°C (−40° to 158°F)

2.10.2 Temperature gradient

Operating	20°C per hour (68°F per hour max), without condensation
Nonoperating	35°C per hour (95°F per hour max), without condensation

2.10.3 Humidity

2.10.3.1 Relative humidity

Operating	5% to 95% noncondensing (30% per hour max)
Nonoperating	5% to 95% noncondensing (30% per hour max)

2.10.3.2 Wet bulb temperature

Operating	37.7°C (99.86°F max)
Nonoperating	40°C (104°F max)

2.10.4 Altitude

Operating	−304.8 m to 3,048 m (−1000 ft to 10,000 ft)
Nonoperating	−304.8 m to 12,192 m (−1000 ft to 40,000 ft)

2.10.5 Shock

All shock specifications assume that the drive is mounted securely with the input shock applied at the drive mounting screws. Shock may be applied in the X, Y or Z axis.

2.10.5.1 Operating shock

These drives comply with the performance levels specified in this document when subjected to a maximum operating shock of 350 Gs based on half-sine shock pulses of 2ms. Shocks should not be repeated more than two times per second.

2.10.5.2 Nonoperating shock

The nonoperating shock level that the drive can experience without incurring physical damage or degradation in performance when subsequently put into operation is 1000 Gs based on a nonrepetitive half-sine shock pulse of 1ms duration.

2.10.6 Vibration

All vibration specifications assume that the drive is mounted securely with the input vibration applied at the drive mounting screws. Vibration may be applied in the X, Y or Z axis.

2.10.6.1 Operating vibration

The maximum vibration levels that the drive may experience while meeting the performance standards specified in this document are specified below.

5–500 Hz	1.0 G (0 to peak). Max displacement may apply below 10 Hz.
----------	--

2.10.6.2 Nonoperating vibration

The maximum nonoperating vibration levels that the drive may experience without incurring physical damage or degradation in performance when subsequently put into operation are specified below.

5–500 Hz:	5.0 Gs (0 to peak). Max displacement may apply below 22 Hz.
-----------	---

2.11 Acoustics

Drive emission of sound is measured consistent with the ECMA-74 and its' referenced standards. Testing is conducted at room temperature (approximately 25°C). Emission levels are reported as the total A-weighted sound power levels for steady state, idle, and active seek modes of operation.

Table 5: Drive A-weighted Sound Power Levels (SWL, BA)

Idle*	Seek
2.4 bels (typ) 2.6 bels (max)	2.6 bels (typ) 2.7 bels (max)

*During periods of drive idle, some offline activity may occur according to the S.M.A.R.T. specification, which may increase acoustic and power to operational levels.

Test for Prominent Discrete Tones (PDTs)

Seagate follows the ECMA-74 standards for measurement and identification of PDTs. An exception to this process is the use of the absolute threshold of hearing. Seagate uses the lower limit for the threshold curve* to discern tone audibility and to compensate for the inaudible components of sound prior to computation of tone ratios according to Annex D of the ECMA-74 standards.

*Defined as the median curve given by ISO 389-7 (Tf curve) minus 10dB at all frequencies.

2.12 Electromagnetic immunity

When properly installed in a representative host system, the drive operates without errors or degradation in performance when subjected to the radio frequency (RF) environments defined in the following table:

Table 6: Radio frequency environments

Test	Description	Performance level	Reference standard
Electrostatic discharge	Contact, HCP, VCP: ± 4 kV; Air: ± 8 kV	B	EN 61000-4-2: 95
Radiated RF immunity	80 to 2000 MHz, 10 V/m, 80% AM with 1 kHz sine 900 MHz, 3 V/m, 50% pulse modulation @ 200 Hz	A	EN 61000-4-3: 96 ENV 50204: 95
Electrical fast transient	± 1 kV on AC mains, ± 0.5 kV on external I/O	B	EN 61000-4-4: 95
Surge immunity	± 1 kV differential, ± 2 kV common, AC mains	B	EN 61000-4-5: 95
Conducted RF immunity	150 kHz to 80 MHz, 3 Vrms, 80% AM with 1 kHz sine	A	EN 61000-4-6: 97
Power Frequency H-field immunity	1 A/m, 50Hz/60Hz, 3 axes	A	EN 61000-4-8: 97
Voltage dips, interrupts	30% Reduction for 25 cycles >95% Reduction for 250 cycles >95%, 0.5 cycles	C C B	EN 61000-4-11: 94

2.13 Reliability

Measurement type	Specification
Nonrecoverable read errors	1 per 10 ¹⁴ bits read, max.
Annualized Failure Rate (AFR)	<0.48%
Load/Unload (U/UL) 25°C, 50% relative humidity 32°C, 80% relative humidity 5°C, 80% relative humidity 5°C, 10% relative humidity 55°C, 16% relative humidity	600,000 software-controlled power on/off cycles 50,000 hard power on/off cycles 600,000 software-controlled power on/off cycles 50,000 hard power on/off cycles
Warranty	To determine the warranty for a specific drive, use a web browser to access the following web page: support.seagate.com/customer/warranty_validation.jsp You will be asked to provide the drive serial number, model number (or part number) and country of purchase. After submitting this information, the system will display the warranty information for your drive.

2.14 Agency certification

2.14.1 Safety certification

These products are certified to meet the requirements of UL60950-1, CSA60950-1 and EN60950 and so marked as to the certify agency.

2.14.2 Electromagnetic compatibility

Hard drives that display the CE mark comply with the European Union (EU) requirements specified in the Electromagnetic Compatibility Directive (2004/108/EC) as put into place 20 July 2007. Testing is performed to the levels specified by the product standards for Information Technology Equipment (ITE). Emission levels are defined by EN 55022, Class B and the immunity levels are defined by EN 55024.

Drives are tested in representative end-user systems. Although CE-marked Seagate drives comply with the directives when used in the test systems, we cannot guarantee that all systems will comply with the directives. The drive is designed for operation inside a properly designed enclosure, with properly shielded I/O cable (if necessary) and terminators on all unused I/O ports. Computer manufacturers and system integrators should confirm EMC compliance and provide CE marking for their products.

Korean RRL

If these drives have the Korean Communications Commission (KCC) logo, they comply with paragraph 1 of Article 11 of the Electromagnetic Compatibility control Regulation and meet the Electromagnetic Compatibility (EMC) Framework requirements of the Radio Research Laboratory (RRL) Communications Commission, Republic of Korea.

These drives have been tested and comply with the Electromagnetic Interference/Electromagnetic Susceptibility (EMI/EMS) for Class B products. Drives are tested in a representative, end-user system by a Korean-recognized lab.

- Certificate number: STX-Momentum (B)
- Trade name or applicant: Seagate Technology LLC
- Manufacturing date: May 25, 2009 (Date of Certification)
- Manufacturer/nationality: USA, Singapore and China

Australian C-Tick (N176)

If these models have the C-Tick marking, they comply with the Australia/New Zealand Standard AS/NZ CISPR22 and meet the Electromagnetic Compatibility (EMC) Framework requirements of the Australian Communication Authority (ACA).

2.14.3 FCC verification

These drives are intended to be contained solely within a personal computer or similar enclosure (not attached as an external device). As such, each drive is considered to be a subassembly even when it is individually marketed to the customer. As a subassembly, no Federal Communications Commission verification or certification of the device is required.

Seagate Technology LLC has tested this device in enclosures as described above to ensure that the total assembly (enclosure, disc drive, motherboard, power supply, etc.) does comply with the limits for a Class B computing device, pursuant to Subpart J, Part 15 of the FCC rules. Operation with noncertified assemblies is likely to result in interference to radio and television reception.

Radio and television interference. This equipment generates and uses radio frequency energy and if not installed and used in strict accordance with the manufacturer's instructions, may cause interference to radio and television reception.

This equipment is designed to provide reasonable protection against such interference in a residential installation. However, there is no guarantee that interference will not occur in a particular installation. If this equipment does cause interference to radio or television, which can be determined by turning the equipment on and off, you are encouraged to try one or more of the following corrective measures:

- Reorient the receiving antenna.
- Move the device to one side or the other of the radio or TV.
- Move the device farther away from the radio or TV.
- Plug the computer into a different outlet so that the receiver and computer are on different branch outlets.

If necessary, you should consult your dealer or an experienced radio/television technician for additional suggestions. You may find helpful the following booklet prepared by the Federal Communications Commission: *How to Identify and Resolve Radio-Television Interference Problems*. This booklet is available from the Superintendent of Documents, U.S. Government Printing Office, Washington, DC 20402. Refer to publication number 004-000-00345-4.

2.15 Environmental protection

Seagate designs its products to meet environmental protection requirements worldwide, including regulations restricting certain chemical substances.

2.15.1 European Union Restriction of Hazardous Substances (RoHS)

The European Union Restriction of Hazardous Substances (RoHS) Directive, restricts the presence of chemical substances, including Lead, Cadmium, Mercury, Hexavalent Chromium, PBB and PBDE, in electronic products, effective July 2006. This drive is manufactured with components and materials that comply with the RoHS Directive.

2.15.2 China Restriction of Hazardous Substances (RoHS) Directive

中国限制危险物品的指令

This product has an Environmental Protection Use Period (EPUP) of 20 years. The following table contains information mandated by China's "Marking Requirements for Control of Pollution Caused by Electronic Information Products" Standard.



该产品具有20年的环境保护使用周期（EPUP）。下表包含了中国“电子产品所导致的污染的控制的记号要求”所指定的信息。

Name of Parts 部件名称	Toxic or Hazardous Substances or Elements 有毒有害物质或元素					
	Lead 铅 (Pb)	Mercury 汞 (Hg)	Cadmium 镉 (Cd)	Hexavalent Chromium 六价铬 (Cr6+)	Polybrominated Biphenyl 多溴联苯 (PBB)	Polybrominated Diphenyl Ether 多溴二苯醚 (PBDE)
PCBA	X	O	O	O	O	O
HDA	X	O	O	O	O	O

"O" indicates the hazardous and toxic substance content of the part (at the homogenous material level) is lower than the threshold defined by the China RoHS MCV Standard.

“O”表示该部件（于同类物品程度上）所含的危险和有毒物质低于中国RoHS MCV标准所定义的阈值。

"X" indicates the hazardous and toxic substance content of the part (at the homogenous material level) is over the threshold defined by the China RoHS MCV Standard.

“X”表示该部件（于同类物品程度上）所含的危险和有毒物质超出中国RoHS MCV标准所定义的阈值。

2.16 Corrosive environment

Seagate electronic drive components pass accelerated corrosion testing equivalent to 10 years exposure to light industrial environments containing sulfurous gases, chlorine and nitric oxide, classes G and H per ASTM B845. However, this accelerated testing cannot duplicate every potential application environment.

Users should use caution exposing any electronic components to uncontrolled chemical pollutants and corrosive chemicals as electronic drive component reliability can be affected by the installation environment. The silver, copper, nickel and gold films used in Seagate products are especially sensitive to the presence of sulfide, chloride, and nitrate contaminants. Sulfur is found to be the most damaging. In addition, electronic components should never be exposed to condensing water on the surface of the printed circuit board assembly (PCBA) or exposed to an ambient relative humidity greater than 95%. Materials used in cabinet fabrication, such as vulcanized rubber, that can outgas corrosive compounds should be minimized or eliminated. The useful life of any electronic equipment may be extended by replacing materials near circuitry with sulfide-free alternatives.

3.0 Configuring and mounting the drive

This section contains the specifications and instructions for configuring and mounting the drive.

3.1 Handling and static-discharge precautions

After unpacking, and before installation, the drive may be exposed to potential handling and electrostatic discharge (ESD) hazards. Observe the following standard handling and static-discharge precautions:

Caution:

- Keep the drive in the electrostatic discharge (ESD) bag until you are ready for installation to limit the drive's exposure to ESD.
- Before handling the drive, put on a grounded wrist strap, or ground yourself frequently by touching the metal chassis of a computer that is plugged into a grounded outlet. Wear a grounded wrist strap throughout the entire installation procedure.
- Handle the drive only by its edges or frame.
- The drive is fragile—handle it with care. Do not press down on the drive top cover.
- Always rest the drive on a padded, antistatic surface until you mount it in the computer.
- Do not touch the connector pins or the printed circuit board.
- Do not remove the factory-installed labels from the drive or cover them with additional labels. Removal voids the warranty. Some factory-installed labels contain information needed to service the drive. Other labels are used to seal out dirt and contamination.

3.2 Configuring the drive

Each drive on the Serial ATA interface connects in a point-to-point configuration with the Serial ATA host adapter. There is no master/slave relationship because each drive is considered a master in a point-to-point relationships. If two drives are attached on one Serial ATA host adapter, the host operating system views the two devices as if they were both “masters” on two separate ports. This means both drives behave as if they are Device 0 (master) devices.

Serial ATA drives are designed for easy installation. It is normally not necessary to set any jumpers on this drive for proper operation. If the host system does not support SATA 3Gb/s operation, place a jumper on pins 1 and 2 to limit the drive to 1.5Gb/s operation.

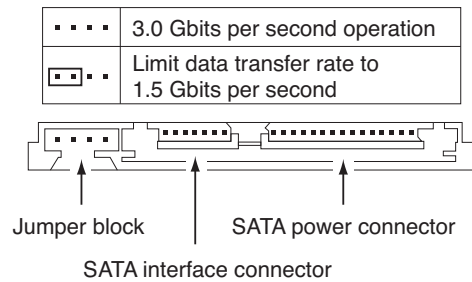

Figure 2. Serial ATA connectors

3.3 Serial ATA cables and connectors

The Serial ATA interface cable consists of four conductors in two differential pairs, plus three ground connections. The cable size may be 30 to 26 AWG with a maximum length of one meter (39.37in). See Table 7 for connector pin definitions. Either end of the SATA signal cable can be attached to the drive or host.

For direct backplane connection, the drive connectors are inserted directly into the host receptacle. The drive and the host receptacle incorporate features that enable the direct connection to be hot pluggable and blind mateable.

For installations which require cables, you can connect the drive as illustrated in Figure 3.

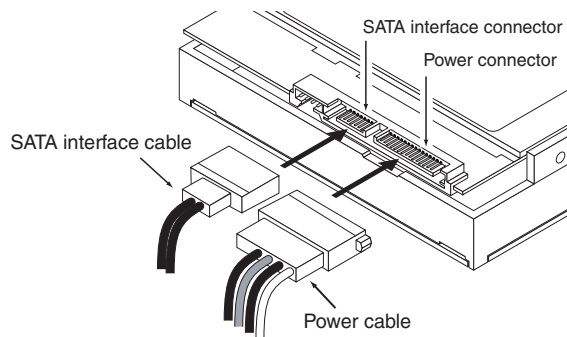

Figure 3. Attaching SATA cabling

Each cable is keyed to ensure correct orientation.

3.4 Drive mounting

You can mount the drive using four screws in the side-mounting holes or four screws in the bottom-mounting holes. See Figure 4 for drive mounting dimensions. Follow these important mounting precautions when mounting the drive:

- Allow a minimum clearance of 0.030in (0.76 mm) around the entire perimeter of the drive for cooling.
- Use only M3 UNC mounting screws.
- Do not overtighten the mounting screws. Maximum torque: 4.0 inch-lb (0.4519 N-m).
- Four (4) threads (0.080in, 2.032 mm) minimum screw engagement recommended.
- Avoid excessive drive distortion when mounting. Refer to the following specifications for stiffness/deflection information:

Top cover stiffness/deflection	
Operating with no performance degradation, emitted noise, mechanical damage, or hard errors	10 mm probe: 1.5kgf or 5 mm probe: 0.92kgf
Non-operating with no hard errors	20 mm probe: 2kgf at any point of top cover 20 mm probe: 15kgf at top cover edges only

Measurements shown in Figure 4 are in inches.

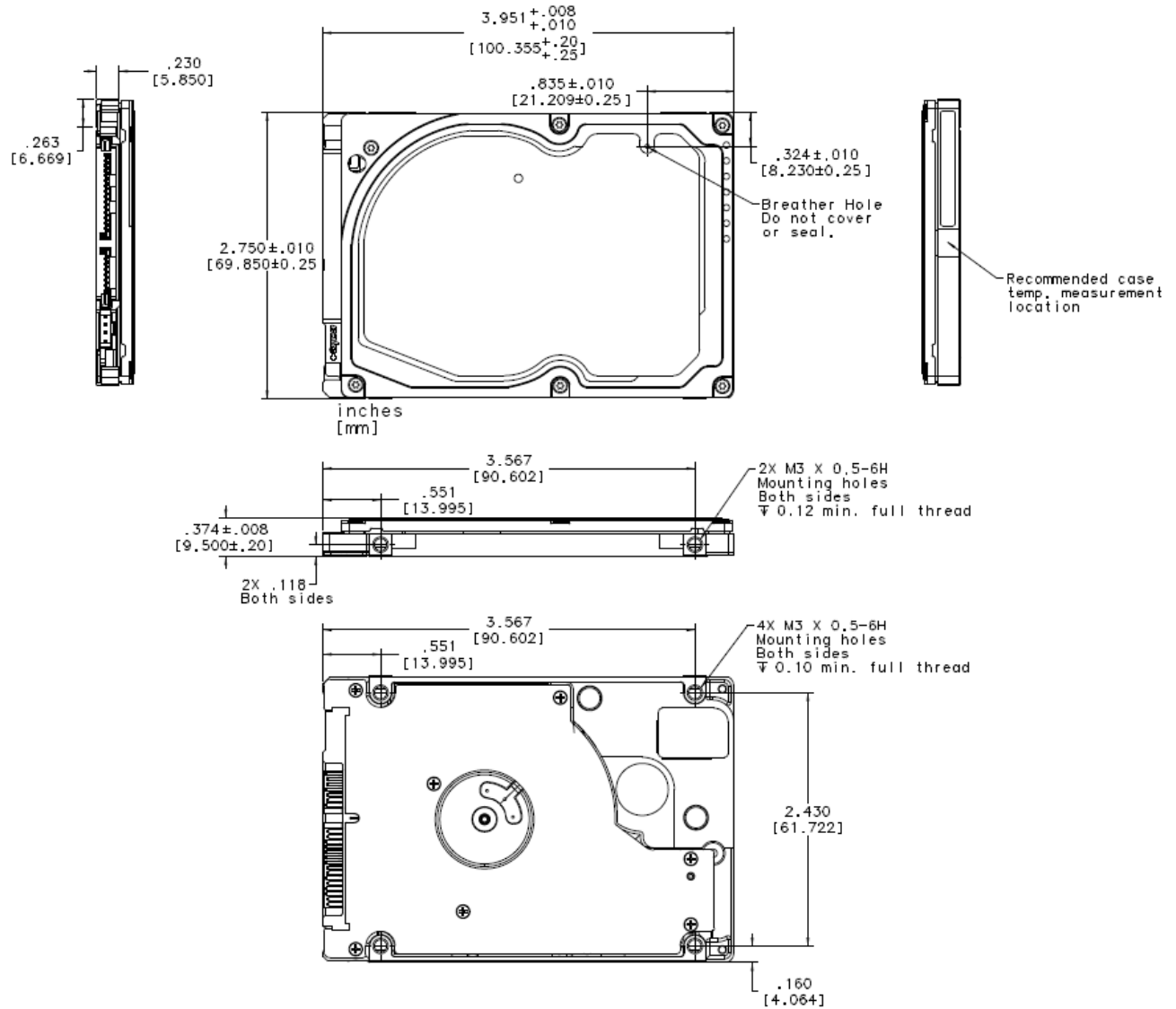

Figure 4. Mounting dimensions—top, side and end view

4.0 Serial ATA (SATA) interface

These drives use the industry-standard Serial ATA interface that supports FIS data transfers. It supports ATA programmed input/output (PIO) modes 0–4; multiword DMA modes 0–2, and Ultra DMA modes 0–6. The drive also supports the use of the IORDY signal to provide reliable high-speed data transfers.

For detailed information about the Serial ATA interface, refer to the “Serial ATA: High Speed Serialized AT Attachment” specification.

4.1 Hot-Plug compatibility

Momentum SATA drives incorporate connectors which enable you to hot plug these drives in accordance with the Serial ATA: High Speed Serialized AT Attachment specification revision 2.0. This specification can be downloaded from <http://www.serialata.org>. This device requires a COMRESET from the host after a hotplug event.

4.2 Serial ATA device plug connector pin definitions

Table 7 summarizes the signals on the Serial ATA interface and power connectors.

Table 7: Serial ATA connector pin definitions

Segment	Pin	Function	Definition
Signal	S1	Ground	2nd mate
	S2	A+	Differential signal pair A from Phy
	S3	A-	
	S4	Ground	2nd mate
	S5	B-	Differential signal pair B from Phy
	S6	B+	
	S7	Ground	2nd mate

Key and spacing separate signal and power segments

Table 7: Serial ATA connector pin definitions

Segment	Pin	Function	Definition
Power	P1	V ₃₃	3.3V power
	P2	V ₃₃	3.3V power
	P3	V ₃₃	3.3V power, pre-charge, 2nd mate
	P4	Ground	1st mate
	P5	Ground	2nd mate
	P6	Ground	2nd mate
	P7	V ₅	5V power, pre-charge, 2nd mate
	P8	V ₅	5V power
	P9	V ₅	5V power
	P10	Ground	2nd mate
	P11	Reserved	The pin corresponding to P11 in the backplane receptacle connector is also reserved The corresponding pin to be mated with P11 in the power cable receptacle connector shall always be grounded
	P12	Ground	1st mate.
	P13	V ₁₂	12V power, pre-charge, 2nd mate
	P14	V ₁₂	12V power
	P15	V ₁₂	12V power

Notes:

1. All pins are in a single row, with a 1.27mm (0.050in) pitch.
2. The comments on the mating sequence apply to the case of backplane blindmate connector only. In this case, the mating sequences are:
 - the ground pins P4 and P12.
 - the pre-charge power pins and the other ground pins.
 - the signal pins and the rest of the power pins.
3. There are three power pins for each voltage. One pin from each voltage is used for pre-charge when installed in a blind-mate backplane configuration.
4. All used voltage pins (V_x) must be terminated.

4.3 Supported ATA commands

The following table lists Serial ATA standard commands that the drive supports. For a detailed description of the ATA commands, refer to the Serial ATA: High Speed Serialized AT Attachment specification. See “S.M.A.R.T. commands” on page 28 for details and subcommands used in the S.M.A.R.T. implementation.

Command name	Command code (in hex)	
ATA-standard commands		
Device Configuration Restore	B1h/C0h	
Device Configuration Freeze Lock	B1h/C1h	
Device Configuration Identify	B1h/C2h	
Device Configuration Set	B1h/C3h	
Download Microcode	92h	
Execute Device Diagnostics	90h	
Flush Cache	E7h	
Flush Cache Extended	EAh	
Identify Device	ECh	
Initialize Device Parameters	91h	
Read Buffer	E4h	
Read DMA	C8h	
Read DMA Extended	25h	
Read DMA without Retries	C9h	
Read Long with Retries	22h	
Read Long without Retries	23h	
Read Multiple	C4h	
Read Multiple Extended	29h	
Read Native Max Address	F8h	
Read Native Max Address Extended	27h	
Read Sectors	20h	
Read Sectors Extended	24h	
Read Sectors without Retries	21h	
Read Verify Sectors	40h	
Read Verify Sectors Extended	42h	
Read Verify Sectors without Retries	41h	
Seek	70h	
Set Features	EFh	
Set Max Address	F9h	
Note: Individual Set Max commands are identified by the value placed in the Set Max Features register as defined to the right.	Address:	00 _H
	Password:	01 _H
	Lock:	02 _H
	Unlock:	03 _H
	Freeze Lock:	04 _H
Set Multiple Mode	C6h	
S.M.A.R.T. Disable Operations	B0h/D9h	

Command name	Command code (in hex)
S.M.A.R.T. Enable/Disable Autosave	B0h/D2h
S.M.A.R.T. Enable Operations	B0h/D8h
S.M.A.R.T. Enable/Disable Auto Offline	B0h/DBh
S.M.A.R.T. Enable One Attribute Modification	B0h/E0h
S.M.A.R.T. Execute Offline	B0h/D4h
S.M.A.R.T. Read Attribute Thresholds	B0h/D1h
S.M.A.R.T. Read Data	B0h/D0h
S.M.A.R.T. Read Log Sector	B0h/D5h
S.M.A.R.T. Return Status	B0h/DAh
S.M.A.R.T. Save Attribute Values	B0h/D3h
S.M.A.R.T. Write Attribute Thresholds	B0h/D7h
S.M.A.R.T. Write Attribute Values	B0h/E1h
S.M.A.R.T. Write Log Sector	B0h/D6h
Write Buffer	E8h
Write DMA	CAh
Write DMA Extended	35h
Write DMA without Retries	CBh
Write Long with Retries	32h
Write Long without Retries	33h
Write Multiple	C5h
Write Multiple Extended	39h
Write Sectors	30h, 31h
Write Sectors Extended	34h
Write Uncorrectable	45h
ATA-standard power-management commands	
Check Power Mode	E5h
Idle	E3h
Idle Immediate	E1h
Sleep	E6h
Standby	E2h
Standby Immediate	E0h
ATA-standard security commands	
Security Set Password	F1h
Security Unlock	F2h
Security Erase Prepare	F3h
Security Erase Unit	F4h
Security Freeze Lock	F5h
Security Disable Password	F6h

4.3.1 Identify Device command

The Identify Device command (command code EC_H) transfers information about the drive to the host following power up. The data is organized as a single 512-byte block of data, whose contents are shown in the table on page 27. All reserved bits or words should be set to zero. Parameters listed with an “x” are drive-specific or vary with the state of the drive.

The following commands contain drive-specific features that may not be included in the Serial ATA specification.

Word	Description	Value
0	Configuration information: • Bit 15: 0 = ATA; 1 = ATAPI • Bit 7: removable media • Bit 6: removable controller • Bit 0: reserved	0C5A _H
1	Number of logical cylinders	16,383
2	ATA-reserved	0000 _H
3	Number of logical heads	16
4	Retired	0000 _H
5	Retired	0000 _H
6	Number of logical sectors per logical track: 63	003F _H
7–9	Retired	0000 _H
10–19	Serial number: (20 ASCII characters, 0000 _H = none)	ASCII
20	Retired	0000 _H
21	Retired	0400 _H
22	Obsolete	0000 _H
23–26	Firmware revision (8 ASCII character string, padded with blanks to end of string)	x.xx
27–46	Drive model number: (40 ASCII characters, padded with blanks to end of string)	ST9640320AS ST9320310AS ST9160316AS
47	(Bits 7–0) Maximum sectors per interrupt on Read multiple and Write multiple (16)	8010 _H
48	Reserved	0000 _H
49	Standard Standby timer, IORDY supported and may be disabled	2F00 _H
50	ATA-reserved	0000 _H
51	PIO data-transfer cycle timing mode	0200 _H
52	Retired	0200 _H
53	Words 54–58, 64–70 and 88 are valid	0007 _H
54	Number of current logical cylinders	xxxx _H
55	Number of current logical heads	xxxx _H
56	Number of current logical sectors per logical track	xxxx _H
57–58	Current capacity in sectors	xxxx _H
59	Number of sectors transferred during a Read Multiple or Write Multiple command	xxxx _H

Word	Description	Value
60–61	Total number of user-addressable sectors This field contains a value that is one greater than the total number of user-addressable sectors. The maximum value that shall be placed in this field is 0FFFFFFh. The 0FFFFFFh value applies to all capacities over 137Gbytes (see Section 2.2 and 2.3 for related information).	0FFFFFFh
62	Retired	0000 _H
63	Multiword DMA active and modes supported (see note following this table)	xx07 _H
64	Advanced PIO modes supported (modes 3 and 4 supported)	0003 _H
65	Minimum multiword DMA transfer cycle time per word (120 nsec)	0078 _H
66	Recommended multiword DMA transfer cycle time per word (120 nsec)	0078 _H
67	Minimum PIO cycle time without IORDY flow control (240 nsec)	00F0 _H
68	Minimum PIO cycle time with IORDY flow control (120 nsec)	0078 _H
69–74	ATA-reserved	0000 _H
75	Queue depth	001F _H
76	Serial ATA capabilities	0508 _H
77	ATA-reserved	0000 _H
78	Serial ATA features supported	0048 _H
79	Serial ATA features enabled	0040 _H
80	Major version number	003E _H
81	Minor version number	0028 _H
82	Command sets supported	306B _H
83	Command sets supported	4001 _H
84	Command sets support extension	4000 _H
85	Command sets enabled	30xx _H
86	Command sets enabled	0001 _H
87	Command sets enable extension	4000 _H
88	Ultra DMA support and current mode (see note following this table)	xx7F _H
89	Security erase time	0000 _H
90	Enhanced security erase time	0000 _H
92	Master password revision code	FFFE _H
93	Hardware reset value (see description following this table)	xxxx _H
94	Auto acoustic management setting	xxxx _H
95–99	ATA-reserved	0000 _H
100–103	Total number of user-addressable LBA sectors available (see Section 2.2 for related information) These words are required for drives that support the 48-bit addressing feature. Maximum value: 0000FFFFFFFFFh.	0FFFFFFh

Word	Description	Value
104–118	ATA-reserved	0000 _H
119	Free Fall Protection support (bit 5)	1 = Free Fall Protection supported 0 = Free Fall Protection not supported
120	Free Fall Protection enable/disable (bit 5)	1 = Free Fall Protection feature is enabled 0 = Free Fall Protection feature is disabled
121–127	ATA reserved	0000 _H
128	Security status	0001 _H
129–159	Seagate-reserved	xxxx _H
160–254	ATA-reserved	0000 _H
255	Integrity word	xxA5 _H

Note. See the bit descriptions below for words 63, 88, and 93 of the Identify Drive data:

Description (if bit is set to 1)

Bit	Word 63
0	Multiword DMA mode 0 is supported.
1	Multiword DMA mode 1 is supported.
2	Multiword DMA mode 2 is supported.
8	Multiword DMA mode 0 is currently active.
9	Multiword DMA mode 1 is currently active.
10	Multiword DMA mode 2 is currently active.
Bit	Word 88
0	Ultra DMA mode 0 is supported.
1	Ultra DMA mode 1 is supported.
2	Ultra DMA mode 2 is supported.
3	Ultra DMA mode 3 is supported.
4	Ultra DMA mode 4 is supported.
5	Ultra DMA mode 5 is supported
6	Ultra DMA mode 6 is supported
8	Ultra DMA mode 0 is currently active.
9	Ultra DMA mode 1 is currently active.
10	Ultra DMA mode 2 is currently active.
11	Ultra DMA mode 3 is currently active.
12	Ultra DMA mode 4 is currently active.
13	Ultra DMA mode 5 is currently active.
14	Ultra DMA mode 6 is currently active.
Bit	Word 93
13	1 = 80-conductor cable detected, CBLID above V _{IH} 0 = 40-conductor cable detected, CBLID below V _{IL}

4.3.2 Set Features command

This command controls the implementation of various features that the drive supports. When the drive receives this command, it sets BSY, checks the contents of the Features register, clears BSY and generates an interrupt. If the value in the register does not represent a feature that the drive supports, the command is aborted. Power-on default has the read look-ahead and write caching features enabled. The acceptable values for the Features register are defined as follows:

Table 8: Set Features command values

02 _H	Enable write cache (<i>default</i>).
03 _H	Set transfer mode (based on value in Sector Count register). Sector Count register values:
00 _H	Set PIO mode to default (PIO mode 2).
01 _H	Set PIO mode to default and disable IORDY (PIO mode 2).
08 _H	PIO mode 0
09 _H	PIO mode 1
0A _H	PIO mode 2
0B _H	PIO mode 3
0C _H	PIO mode 4 (<i>default</i>)
20 _H	Multiword DMA mode 0
21 _H	Multiword DMA mode 1
22 _H	Multiword DMA mode 2
40 _H	Ultra DMA mode 0
41 _H	Ultra DMA mode 1
42 _H	Ultra DMA mode 2
43 _H	Ultra DMA mode 3
44 _H	Ultra DMA mode 4
45 _H	Ultra DMA mode 5
46 _H	Ultra DMA mode 6
55 _H	Disable read look-ahead (read cache) feature.
82 _H	Disable write cache
AA _H	Enable read look-ahead (read cache) feature (<i>default</i>).
C1 _H	Disable the Free Fall Protection feature (41 _H above enables the Free Fall Protection feature)
F1 _H	Report full capacity available

Note. At power-on, or after a hardware or software reset, the default values of the features are as indicated above.

4.3.3 S.M.A.R.T. commands

S.M.A.R.T. provides near-term failure prediction for disc drives. When S.M.A.R.T. is enabled, the drive monitors predetermined drive attributes that are susceptible to degradation over time. If self-monitoring determines that a failure is likely, S.M.A.R.T. makes a status report available to the host. Not all failures are predictable. S.M.A.R.T. predictability is limited to the attributes the drive can monitor. For more information on S.M.A.R.T. commands and implementation, see the *Draft ATA-8 Standard*.

SeaTools diagnostic software activates a built-in drive self-test (DST S.M.A.R.T. command for D4_H) that eliminates unnecessary drive returns. The diagnostic software ships with all new drives and is also available at: <http://seatools.seagate.com>.

This drive is shipped with S.M.A.R.T. features disabled. You must have a recent BIOS or software package that supports S.M.A.R.T. to enable this feature. The table below shows the S.M.A.R.T. command codes that the drive uses.

Table 9: S.M.A.R.T. commands

Code in features register	S.M.A.R.T. command
D0 _H	S.M.A.R.T. Read Data
D1 _H	Vendor-specific
D2 _H	S.M.A.R.T. Enable/Disable Attribute Autosave
D3 _H	S.M.A.R.T. Save Attribute Values
D4 _H	S.M.A.R.T. Execute Off-line Immediate (runs DST)
D5 _H	S.M.A.R.T. Read Log Sector
D6 _H	S.M.A.R.T. Write Log Sector
D7 _H	Vendor-specific
D8 _H	S.M.A.R.T. Enable Operations
D9 _H	S.M.A.R.T. Disable Operations
DA _H	S.M.A.R.T. Return Status

Note. If an appropriate code is not written to the Features Register, the command is aborted and 0x04 (abort) is written to the Error register.

5.0 Seagate Technology support services

Internet

For information regarding Seagate products and services, visit www.seagate.com.

Worldwide support is available 24 hours daily by email for your questions.

Presales Support:

Presales@Seagate.com

Technical Support:

DiscSupport@Seagate.com

Warranty Support:

http://www.seagate.com/www/en-us/support/warranty_&_returns_assistance

mySeagate

my.seagate.com is the industry's first Web portal designed specifically for OEMs and distributors. It provides self-service access to critical applications, personalized content and the tools that allow our partners to manage their Seagate account functions. Submit pricing requests, orders and returns through a single, password-protected Web interface-anytime, anywhere in the world.

spp.seagate.com

spp.seagate.com supports Seagate resellers with product information, program benefits and sales tools. You may register for customized communications that are not available on the web. These communications contain product launch, EOL, pricing, promotions and other channel-related information. To learn more about the benefits or to register, go to spp.seagate.com, any time, from anywhere in the world.

Global Customer Support

Presales Support

Our Presales Support staff can help you determine which Seagate products are best suited for your specific application or computer system, as well as product availability and compatibility.

Technical Support

Seagate technical support is available to assist you online at support.seagate.com or through one of our call centers. Have your system configuration information and your "ST" model/product number available.

Customer Service Operations

Warranty Service

Seagate offers worldwide customer support for Seagate products. Seagate distributors, OEMs and other direct customers should contact their Seagate Customer Service Operations (CSO) representative for warranty-related issues. Resellers or end users of drive products should contact their place of purchase or Seagate warranty service for assistance. Have your serial number and model or part number available.

Data Recovery Services

Seagate offers data recovery services for all formats and all brands of storage media. Our data recovery services labs are currently located throughout the world. Additional information, including an online request form and data loss prevention resources, is available at <http://services.seagate.com/index.aspx>.

Authorized Service Centers

Seagate Service Centers are available on a global basis for the return of defective products. See www.seagate.com for the service center near you.

USA/Canada/Latin America support services

For an extensive list of telephone numbers to technical support, presales and warranty service in USA/Canada/Latin America, including business hours, go to the "Contact Us" page on www.seagate.com.

Global Customer Support

Presales, Technical, and Warranty Support

Call Center	Toll-free	Direct dial
USA, Canada, and Mexico	1-800-SEAGATE	+1-405-324-4700

Data Recovery Services

Call Center	Toll-free	Direct dial	FAX
USA, Canada, and Mexico	1-800-475-0143	+1-905-474-2162	1-800-475-0158 +1-905-474-2459

Europe, the Middle East and Africa Support Services

For an extensive list of telephone numbers to technical support, presales and warranty service in Europe, the Middle East and Africa, go to the "Contact Us" page on www.seagate.com.

Asia/Pacific Support Services

For an extensive list of telephone numbers to technical support, presales and warranty service in Asia/Pacific, go to the "Contact Us" page on www.seagate.com.

Index

A

- ACA 14
- acoustics 4, 12
- Active mode 9
- Address 22
- AFR 13
- Agency certification 13
- Altitude 10
- Altitude, nonoperating 4
- Altitude, operating 4
- Ambient temperature 4, 10
- ambient temperature 6
- Annualized Failure Rate 13
- Annualized Failure Rate (AFR) 4
- Areal density 3, 6
- ATA commands 22
- ATA data-transfer modes supported 3
- Australia/New Zealand Standard AS/NZ CISPR22 14
- Australian Communication Authority (ACA) 14
- Australian C-Tick 14
- Average seek time 6
- Average seek, read 3

B

- bels 4
- BPI 3
- buffer 3, 6
- Bytes per sector 3, 5

C

- cables and connectors 17
- Cache 3
- cache 6
- capacity 5
- CE mark 13
- certification 13
- Check Power Mode 23
- chemical substances 15
- China RoHS directive 15
- Class B computing device 14
- compatibility 13
- Conducted noise 8
- Conducted RF immunity 12
- Configuring the drive 16
- connectors 17
- CSA60950-1 13
- current 3
- cycles 13
- Cylinders 5

D

- data-transfer rates 1
- DC power 7
- Default logical geometry 5
- density 3
- Device Configuration Freeze Lock 22
- Device Configuration Restore 22
- Device Configuration Set 22
- Diagnostics 22
- dimensions 19
- Discs 3
- dissipation 7
- Download Microcode 22

E

- Electrical fast transient 12
- Electromagnetic compatibility 13
- Electromagnetic Compatibility (EMC) 14
- Electromagnetic Compatibility control Regulation 14
- Electromagnetic Compatibility Directive (2004/108/EC) 13
- Electromagnetic immunity 12
- Electrostatic discharge 12
- electrostatic discharge (ESD) 16
- EN 55022, Class B 13
- EN 55024 13
- EN60950 13
- Environmental protection 15
- Environmental specifications 10
- error-correction algorithms 1
- errors 4, 13
- ESD 16
- EU 13
- European Union (EU) requirements 13
- European Union Restriction of Hazardous Substances 15
- evice Configuration Identify 22
- Execute Device Diagnostics 22

F

- FCC verification 14
- features 1
- Federal Communications Commission 14
- Flush Cache 22
- Flush Cache Extended 22
- Formatted capacity 5
- Formatted Gbytes 3
- Freeze Lock 22

G

- Gbytes 5
- geometry 5
- gradient 4

Guaranteed sectors 3, 5
guaranteed sectors 5

H

handling 16
Handling precautions 16
heads 5
Height 3
height 6
Humidity 10
humidity 4

I

I/O data-transfer rate 3, 6
Identify 22
Identify Device 22
Identify Device command 24
Idle 7, 23
Idle and Standby timers 9
Idle Immediate 23
Idle mode 4, 9
Idle mode power 7
Information Technology Equipment (ITE) 13
Initialize Device Parameters 22
Input noise ripple 8
Interface 6
interface 20
Interleave 6
Internal data transfer rate 3
Internal data-transfer rate 6
ITE 13

K

KCC 14
Korean Communications Commission 14
Korean RRL 14

L

latency 3
LBA mode 5
Length 3
length 6
Load/Unload 13
logical geometry 5

M

master/slave 2
Max Address 22
maximum temperature 10
Microcode 22
mounting 18
mounting screws 11
mounting the drive 16

N

noise 8
nominal power 6
Nonoperating shock 11
Nonoperating vibration 11
Nonrecoverable read errors 4
nonrecoverable read errors 13

O

Operating shock 11
Operating vibration 11

P

Physical characteristics 6
Physical organization 5
Physical read/write heads 3
point-to-point 2, 17
Power consumption 7
power dissipation 7
power management 9
power on/off cycles 13
Power specifications 7
Power-management modes 9
Power-on to Ready 7
Power-on to ready 3
precautions 16, 18
programmable power management 9

Q

quick reference 3

R

Radiated RF immunity 12
Radio and television interference 14
radio frequency (RF) 12
random track location 7
Read Buffer 22
Read DMA 22
Read DMA Extended 22
Read DMA without Retries 22
read errors 4, 13
Read Long with Retries 22
Read Long without Retries 22
Read Multiple 22
Read Multiple Extended 22
Read Native Max Address 22
Read Native Max Address Extended 22
Read Sectors 22
Read Sectors Extended 22
Read Sectors without Retries 22
Read Verify Sectors 22
Read Verify Sectors Extended 22
Read Verify Sectors without Retries 22

- Read/write heads 5
- Read/write power 4
- read/write power and current 7
- Recording density 3, 6
- Recording method 6
- Recording technology 6
- Relative humidity 4, 10
- Reliability 13
- resistance 8
- Retries 22
- RF 12
- RoHS 15
- RPM 3
- RRL 14

S

- S.M.A.R.T. 23
- S.M.A.R.T. implementation 22
- Safety certification 13
- SATA 6, 20
- screws 11, 18
- sector 5
- sectors 5
- Sectors per track 5
- Security Disable Password 23
- Security Erase Prepare 23
- Security Erase Unit 23
- Security Freeze Lock 23
- Security Set Password 23
- Security Unlock 23
- Seek 22
- seek mode 7
- Seek power 4
- Seek time 6
- seek time 3
- Seeking 7
- Self refresh, low power 9
- Serial ATA 6
- Serial ATA (SATA) interface 20
- serial ATA ports 2
- servo electronics 7
- Set Features 22
- Set Max Address 22
- Set Multiple Mode 22
- Shock 11
- Shock, nonoperating 4
- Shock, operating 4
- single-track seeks 6
- Sleep 7, 23
- Sleep mode 4, 9
- sound power 4
- Specification summary table 3
- Spindle speed 3, 6
- Spinup 7
- spinup power 7

- Standby 7, 23
- Standby Immediate 23
- Standby mode 4, 7, 9
- Standby to Ready 7
- Standby to ready 3
- Start/stop times 7
- Startup current 3
- static-discharge 16
- support services 29
- Surge immunity 12

T

- technical support services 29
- temperature 4, 6, 10
- Temperature gradient 4, 10
- timers 9
- TPI 3
- Track density 3, 6
- Track-to-track seek time 3, 6

U

- UL60950-1 13

V

- Vibration 11
- Vibration, nonoperating 4
- Vibration, operating 4
- Voltage dips, interrupts 12
- Voltage tolerance 4, 8

W

- Warranty 13
- Weight 3
- weight 6
- Wet bulb temperature 4, 10
- Width 3
- width 6
- Write Buffer 23
- Write DMA 23
- Write DMA Extended 23
- Write Long with Retries 23
- Write Long without Retries 23
- Write Multiple 23
- Write Sectors 23
- write uncorrectable 23



Seagate Technology LLC
920 Disc Drive, Scotts Valley, California 95066-4544, USA
Publication Number: 100589392, Rev. B, Printed in USA