



# Laptop SSHD

SATA Product Manual

**Standard models**

ST1000LX000  
ST1000LX001  
ST1000LM014  
ST750LM000

**Self-Encrypting  
Drive models**

ST1000LM015

**SED (FIPS 140-2)  
models**

ST1000LM028

## Document Revision History

Revision	Date	Pages Affected and Description of Change
Rev. A	01/08/2013	Initial release
Rev. B	05/01/2013	fc, 1-2, 4-5, 11, 16 & 19-21.
Rev. C	06/05/2013	7.
Rev. D	07/08/2013	2.
Rev. E	01/16/2014	2, 5, 11 & 17-18.
Rev. F	06/24/2014	7 & 15.
Rev. G	08/27/2014	15.
Rev. H	08/05/2015	FC, BC, 5-6, 8-10 & 26-28.

© 2015 Seagate Technology LLC. All rights reserved.

Publication number: 100716627, Rev. H August 2015

Seagate, Seagate Technology and the Spiral logo are registered trademarks of Seagate Technology LLC in the United States and/or other countries. 3D Defense System and SeaTools are either trademarks or registered trademarks of Seagate Technology LLC or one of its affiliated companies in the United States and/or other countries. The FIPS logo is a certification mark of NIST, which does not imply product endorsement by NIST, the U.S., or Canadian governments. All other trademarks or registered trademarks are the property of their respective owners.

No part of this publication may be reproduced in any form without written permission of Seagate Technology LLC.  
Call 877-PUB-TEK1 (877-782-8351) to request permission.

When referring to drive capacity, one gigabyte, or GB, equals one billion bytes and one terabyte, or TB, equals one trillion bytes. Your computer's operating system may use a different standard of measurement and report a lower capacity. In addition, some of the listed capacity is used for formatting and other functions, and thus will not be available for data storage. Actual quantities will vary based on various factors, including file size, file format, features and application software. Actual data rates may vary depending on operating environment and other factors. The export or re-export of hardware or software containing encryption may be regulated by the U.S. Department of Commerce, Bureau of Industry and Security (for more information, visit [www.bis.doc.gov](http://www.bis.doc.gov)), and controlled for import and use outside of the U.S. Seagate reserves the right to change, without notice, product offerings or specifications.

---

<b>Seagate® Technology Support Services</b> .....	<b>5</b>
---	----------

---

<b>1.0 Introduction</b> .....	<b>6</b>
1.1 About the Serial ATA Interface .....	7

---

<b>2.0 Drive Specifications</b> .....	<b>8</b>
2.1 Formatted Capacity .....	9
2.1.1 LBA mode .....	10
2.2 Physical organization .....	10
2.3 Recording and Interface Technology .....	10
2.4 Physical Characteristics .....	10
2.5 Seek time .....	10
2.6 Start/stop times .....	11
2.7 Power Specifications .....	11
2.7.1 Power consumption .....	11
2.7.2 Conducted noise .....	12
2.7.3 Voltage tolerance .....	12
2.7.4 Power management modes .....	13
2.8 Environmental Specifications .....	13
2.8.1 Shock .....	14
2.8.2 Vibration .....	14
2.9 Acoustics .....	14
2.9.1 Test for prominent discrete tones (PDTs) .....	14
2.10 Electromagnetic Immunity .....	15
2.11 Reliability .....	15
2.12 Agency Certification .....	16
2.12.1 Safety certification .....	16
2.12.2 Electromagnetic Compatibility (EMC) .....	16
2.12.3 FCC verification .....	16
2.13 Environmental Protection .....	17
2.13.1 European Union Restriction of Hazardous Substances (RoHS) Directive .....	17
2.13.2 China Restriction of Hazardous Substances (RoHS) Directive .....	17
2.14 Corrosive Environment .....	17

---

<b>3.0 Configuring and Mounting the Drive</b> .....	<b>18</b>
3.1 Handling and Static-Discharge Precautions .....	18
3.2 Configuring the Drive .....	18
3.2.1 Serial ATA Cables and Connectors .....	18
3.3 Drive Mounting .....	19

---

<b>4.0 About FIPS</b> .....	<b>20</b>
-----------------------------	-----------

---

<b>5.0 About (SED) Self-Encrypting Drives</b> .....	<b>21</b>
5.1 Data Encryption .....	21
5.2 Controlled Access .....	21
5.2.1 Admin SP .....	21
5.2.2 Locking SP .....	21
5.2.3 Default password .....	21
5.2.4 ATA Enhanced Security .....	21
5.3 Random Number Generator (RNG) .....	22
5.4 Drive Locking .....	22
5.5 Data Bands .....	22
5.6 Cryptographic Erase .....	22

# CONTENTS

5.7	Authenticated Firmware Download .....	22
5.8	Power Requirements .....	22
5.9	Supported Commands .....	22
5.10	RevertSP .....	22

---

<b>6.0</b>	<b>Serial ATA (SATA) Interface .....</b>	<b>23</b>
6.1	Hot-Plug Compatibility .....	23
6.2	Serial ATA Device Plug Connector Pin Definitions .....	23
6.3	Supported ATA Commands .....	24
6.3.1	Identify Device command .....	26
6.3.2	Set Features command .....	30
6.3.3	S.M.A.R.T. commands .....	31

Figure 1	Typical 5V Startup and Operation Current Profile . . . . .	12
Figure 2	Attaching SATA Cabling . . . . .	18
Figure 3	Mounting Dimensions (for standard models) . . . . .	19
Figure 4	Example of FIPS tamper evidence labels. . . . .	20

# Seagate® Technology Support Services

For information regarding online support and services, visit: <http://www.seagate.com/contacts/>

Available services include:

- Presales & Technical support
- Global Support Services telephone numbers & business hours
- Authorized Service Centers

For information regarding Warranty Support, visit: <http://www.seagate.com/support/warranty-and-replacements/>

For information regarding data recovery services, visit: <http://www.seagate.com/services-software/data-recovery-services/>

For Seagate OEM and Distribution partner portal, visit: <http://www.seagate.com/partners/>

For Seagate reseller portal, visit: <http://www.seagate.com/partners/my-spp-dashboard/>

## 1.0 Introduction

This manual describes the functional, mechanical and interface specifications for the following Seagate® Laptop SSHD model drives:

Standard models		Standard SED models	SED (FIPS 140-2) models
ST1000LX000	ST1000LM014	ST1000LM015	ST1000LM028
ST1000LX001	ST750LM000		

### Note

Previous generations of Seagate Self-Encrypting Drive models were called Full Disk Encryption (FDE) models before a differentiation between drive-based encryption and other forms of encryption was necessary.

For more information on SED drives see [About \(SED\) Self-Encrypting Drives](#) on page 21.

For more information on FIPS 140-2 Level 2 certification [About FIPS](#) on page 20.

These drives provide the following key features:

- 5400-RPM spindle speed.
- 64MB buffer.
- 8GB NAND flash on models ST1000LM014, ST1000LM015, ST1000LM028 & ST750LM000
- 16GB NAND flash on model ST1000LX000
- 32GB NAND flash on model ST1000LX001

### Note

For improved reliability, Seagate SSHDs incorporate a technique referred to as 'Combo Mode', utilizing proprietary controls to reduce the number of bits stored to a portion of the NAND Flash.

- Quiet operation. Fluid Dynamic Bearing (FDB) motor.
- High instantaneous (burst) data-transfer rates (up to 6Gb/s).
- Perpendicular recording technology.
- State-of-the-art cache and on-the-fly error-correction algorithms.
- Native Command Queuing (NCQ) with command ordering.
- Full-track multiple-sector transfer capability without local processor intervention.
- 1000 Gs nonoperating shock and 350 Gs of operating shock.
- SeaTools™ diagnostic software performs a drive self-test that eliminates unnecessary drive returns.
- The 3D Defense System™, which includes Drive Defense, Data Defense and Diagnostic Defense, offers the industry's most comprehensive protection for disk drives.
- Support for S.M.A.R.T. drive monitoring and reporting.
- Support for Read Multiple and Write Multiple commands.
- Worldwide Name (WWN) capability uniquely identifies the drive.

Seagate Laptop SSHD Self-Encrypting Drive models have the following additional features

- Automatic data encryption/decryption
- Controlled access
- Random number generator
- Drive locking
- 16 independent data bands
- Cryptographic erase of user data for a drive that will be repurposed or scrapped
- Authenticated firmware download.

There is no significant performance difference between Self-Encrypting Drive and standard (non-Self-Encrypting Drive) models.

## 1.1 About the Serial ATA Interface

The Serial ATA interface provides several advantages over the traditional (parallel) ATA interface. The primary advantages include:

- Easy installation and configuration with true plug-and-play connectivity. It is not necessary to set any jumpers or other configuration options.
- Thinner and more flexible cabling for improved enclosure airflow and ease of installation.
- Scalability to higher performance levels.

In addition, Serial ATA makes the transition from parallel ATA easy by providing legacy software support. Serial ATA was designed to allow users to install a Serial ATA host adapter and Serial ATA disk drive in the current system and expect all of the existing applications to work as normal.

The Serial ATA interface connects each disk drive in a point-to-point configuration with the Serial ATA host adapter. There is no master/slave relationship with Serial ATA devices like there is with parallel ATA. If two drives are attached on one Serial ATA host adapter, the host operating system views the two devices as if they were both “masters” on two separate ports. This essentially means both drives behave as if they are Device 0 (master) devices.

### Note

The host adapter may, optionally, emulate a master/slave environment to host software where two devices on separate Serial ATA ports are represented to host software as a Device 0 (master) and Device 1 (slave) accessed at the same set of host bus addresses. A host adapter that emulates a master/slave environment manages two sets of shadow registers. This is not a typical Serial ATA environment.

The Serial ATA host adapter and drive share the function of emulating parallel ATA device behavior to provide backward compatibility with existing host systems and software. The Command and Control Block registers, PIO and DMA data transfers, resets, and interrupts are all emulated.

The Serial ATA host adapter contains a set of registers that shadow the contents of the traditional device registers, referred to as the Shadow Register Block. All Serial ATA devices behave like Device 0 devices. For additional information about how Serial ATA emulates parallel ATA, refer to the *Serial ATA International Organization: Serial ATA* (Revision 3.0). The specification can be downloaded from [www.serialata.org](http://www.serialata.org).



## 2.0 Drive Specifications

Unless otherwise noted, all specifications are measured under ambient conditions, at 25°C, and nominal power. For convenience, the phrases *the drive* and *this drive* are used throughout this manual to indicate the following drive models:

The specification summaries listed in the following tables are for quick reference. For details on specification measurement or definition, refer to the appropriate section of this manual.

**Table 1 Drive Specifications Summary**

Drive Specification	ST1000LX000	ST1000LX001	ST1000LM014, ST1000LM015 ST1000LM028	ST750LM000
Formatted capacity <sup>(1)</sup>	1TB			750 GB
Guaranteed sectors	1,953,525,168			1,465,149,168
Heads	4			
Disks	2			
Bytes per sector	512 (logical) / 4096 (physical)			
NAND flash Commercial Multilevel Cell (cMLC)	16GB	32GB	8GB	
Recording density	1894 Kb/in			
Track density	375 Ktracks/in avg			
Areal density	705 Gb/in <sup>2</sup> avg			
Spindle speed	5400 RPM			
Sustained data transfer rate OD	100 MB/s max			
I/O data-transfer rate	600 MB/s max			
ATA data-transfer modes supported	PIO modes 0–4 Multiword DMA modes 0–2 Ultra DMA modes 0–6			
Cache buffer	64MB			
Height	9.5 +/- 0.2 mm (0.374 +/- .008 in)			
Width	69.85 +/- 0.25 mm (2.750 +/- 0.010 in)			
Length	100.35 +0.20 / -0.25 mm (3.951 +0.008 / -0.010 in)			
Weight (typical)	115 g (0.254 lb)			
Average latency	5.6 ms			
Startup current (typical) 5V (peak)	1.0 A			
Voltage tolerance (including noise)	5V ± 5%			
Operating temperature	0° to 60°C			
Nonoperating temperature (Ambient)	–40° to 70°C			
Temperature gradient (max)	20°C per hour max (operating) 35°C per hour max (nonoperating)			
Relative humidity	5% to 95% (operating) 5% to 95% (nonoperating)			

**Table 1 Drive Specifications Summary (continued)**

Drive Specification	ST1000LX000	ST1000LX001	ST1000LM014, ST1000LM015 ST1000LM028	ST750LM000
Relative humidity gradient	30% per hour max			
Wet bulb temperature (max)	37.7°C max (operating) 40.0°C max (nonoperating)			
Altitude, operating	–304.8 m to 3048 m (–1000 ft to 10,000+ ft)			
Altitude, nonoperating (below mean sea level, max)	–304.8 m to 12,192 m (–1000 ft to 40,000+ ft)			
Operational Shock	350 Gs at 2 ms max			
Non-Operational Shock	1000 Gs at 1 ms max			
Vibration, operating	5–200 Hz: 2.0 Gs 201–500 Hz: 1.0 Gs			
Vibration, nonoperating	5–500 Hz: 5.0 Gs			
Nonrecoverable read errors	1 per 10 <sup>15</sup> bits read			
Rated workload	Average rate of <55TB/year. The MTBF specification for the drive assumes the I/O workload does not exceed the average annualized workload rate limit of 55TB/year. Workloads exceeding the annualized rate may degrade the drive MTBF and impact product reliability. The average annualized workload rate limit is in units of TB per year, or TB per 8760 power-on hours. Workload rate limit = TB transferred × (8760/recorded power-on hours).			
Warranty	To determine the warranty for a specific drive, use a web browser to access the following web page: <a href="http://www.seagate.com/support/warranty-and-replacements/">http://www.seagate.com/support/warranty-and-replacements/</a> . From this page, click on the “Verify Your Warranty” link. Users will be asked to provide the drive serial number, model number (or part number) and country of purchase. The system will display the warranty information for the drive.			
Load-unload cycles	600,000 at 25°C, 50% rel. humidity			
Supports Hotplug operation per the Serial ATA Revision 3.2 specification	Yes			

1. One GB equals one billion bytes when referring to hard drive capacity. Accessible capacity may vary depending on operating environment and formatting.

## 2.1 Formatted Capacity

Model	Formatted Capacity <sup>(1)</sup>	Guaranteed Sectors	Bytes per Sector
ST1000LX000, ST1000LX001, ST1000LM014, ST1000LM015 and ST1000LM028	1000 GB	1,953,525,168	512 (logical) / 4096 (physical)
ST750LM000	750 GB	1,465,149,168	

1. One GB equals one billion bytes when referring to hard drive capacity. Accessible capacity may vary depending on operating environment and formatting.

### 2.1.1 LBA mode

When addressing these drives in LBA mode, all blocks (sectors) are consecutively numbered from 0 to  $n-1$ , where  $n$  is the number of guaranteed sectors as defined above.

Refer to [Configuring and Mounting the Drive](#) on page 18 (words 60-61 and 100-103) for additional information about 48-bit addressing support of drives with capacities over 137 GB.

## 2.2 Physical organization

Drive model	Read/write heads	Number of discs
ST1000LX000, ST1000LX001, ST1000LM014, ST1000LM015 and ST1000LM028	4	2
ST750LM000		

## 2.3 Recording and Interface Technology

Interface	Serial ATA (SATA)
Recording method	Perpendicular
Recording density	1894 Kb/in
Track density	375 ktracks/in avg
Areal density	705 Gb/in <sup>2</sup> avg
Spindle speed	5400 RPM +/- 0.2%
Sustained data transfer rate	100 MB/s max
I/O data-transfer rate	600 MB/s max

## 2.4 Physical Characteristics

<b>All models</b>	Height	9.5 +/- 0.2 mm (0.374 +/- .008 in)
	Width	69.85 +/- 0.25 mm (2.750 +/- 0.010 in)
	Length	100.35 +0.20 / -0.25 mm (3.951 +0.008 / -0.010 in)
	Typical weight	115 g (0.254 lb)
	Cache buffer	64MB (65,536 KB)

## 2.5 Seek time

Seek measurements are taken with nominal power at 25°C ambient temperature. All times are measured using drive diagnostics. The specifications in the table below are defined as follows:

- Track-to-track seek time is an average of all possible single-track seeks in both directions.
- Average seek time is a true statistical random average of at least 5000 measurements of seeks between random tracks, less overhead.

**Table 2 Typical seek times**

Typical seek times (ms)	Read
Track-to-track	2.0
Average	12.0
Average latency	5.6

### Note

These drives are designed to consistently meet the seek times represented in this manual. Physical seeks, regardless of mode (such as track-to-track and average), are expected to meet the noted values. However, due to the manner in which these drives are formatted, benchmark tests that include command overhead or measure logical seeks may produce results that vary from these specifications.

## 2.6 Start/stop times

**Table 3 Start/stop times**

Typical seek times (ms)	Typical	Max @ 25°C
Power-on to ready (sec)	<1.0	<1.0
Standby to ready (sec)	<1.0	<1.0

## 2.7 Power Specifications

The drive receives DC power (+5V) through a native SATA power connector (refer to [Figure 2](#)).

### 2.7.1 Power consumption

Power requirements for the drives are listed in the table in [Table 4](#). Typical power measurements are based on an average of drives tested, under nominal conditions, at 25°C ambient temperature. These power measurements are done with Interface Power Management modes like HIPM and DIPM enabled.

#### ■ Spinup power

Spinup power is measured from the time of power-on to the time that the drive spindle reaches operating speed.

#### ■ Seek mode

During seek mode, the read/write actuator arm moves toward a specific position on the disk surface and does not execute a read or write operation. Servo electronics are active. Seek mode power is measured based on three random seek operations every 100 ms. This mode is not typical.

#### ■ Read/write power and current

Read/write power is measured with the heads on track, based on three 63 sector read or write operations every 100 ms.

#### ■ Idle mode power

Idle mode power is measured with the drive up to speed, with servo electronics active and with the heads in a random track location.

#### ■ Standby mode

During standby mode, the drive accepts commands, but the drive is not spinning, and the servo and read/write electronics are in power-down mode.

**Table 4 DC Power Requirements**

Power Dissipation	+5V input average (25° C)
Spinup (max)	1.50A
Seek average	2.7W
Write average	3.7W
Read average	3.1W
Idle, performance <sup>(1)</sup>	2.2W
Idle, active	1.1W
Idle, low power mode	0.9W
Standby <sup>(2)</sup>	0.53W
Sleep	0.53W

1. During periods of drive idle, some offline activity may occur according to the S.M.A.R.T. specification, which may increase acoustic and power to operational levels.
2. Standby power is measured at steady state (after 200ms from transition)

### 2.7.1.1 Typical current profiles

The typical 5V startup and operation current profile is shown in [Figure 1](#).

**Figure 1 Typical 5V Startup and Operation Current Profile**

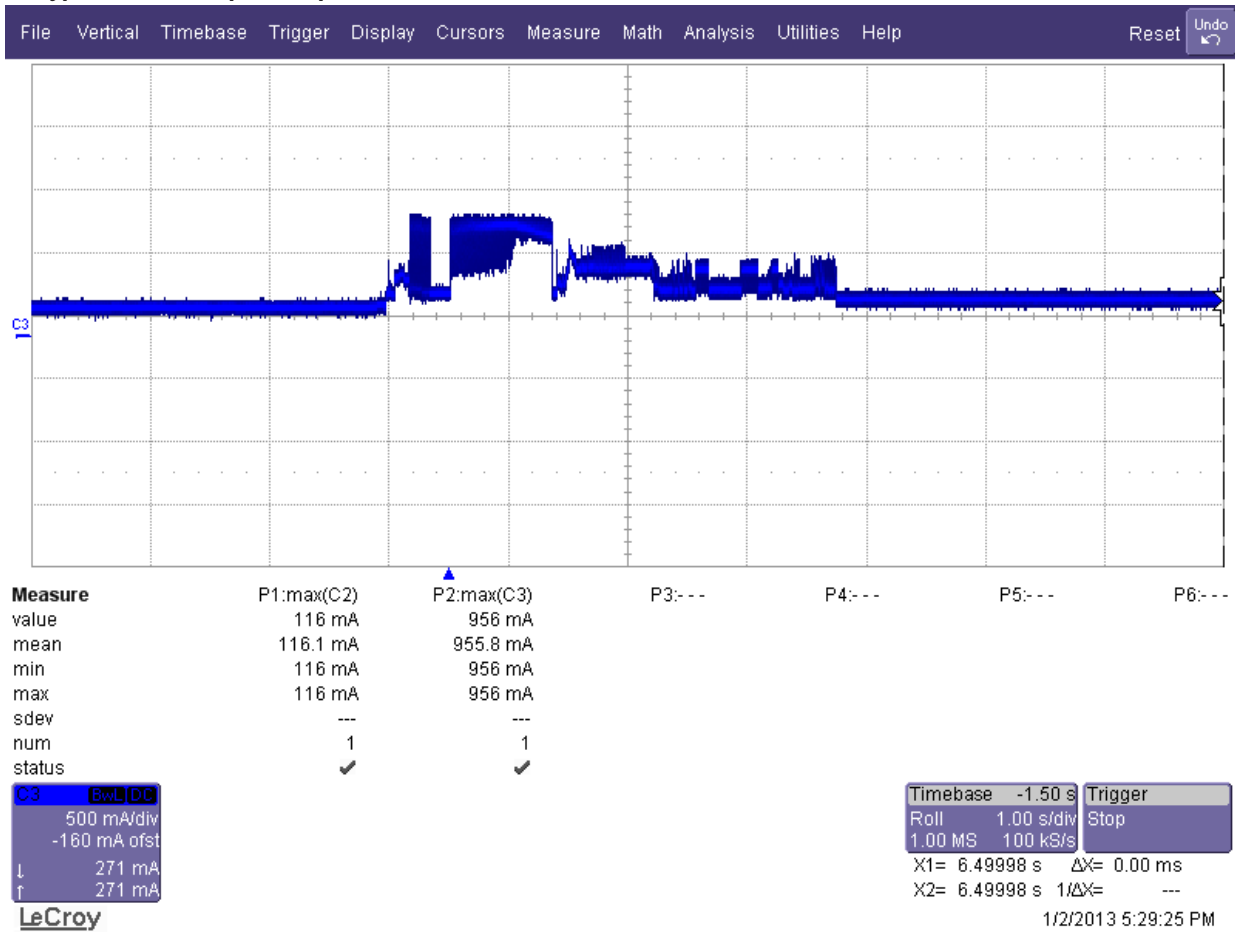

### 2.7.2 Conducted noise

Input noise ripple is measured at the host system power supply across an equivalent 15-ohm resistive load on the +5 volt line.

- Using 5-volt power, the drive is expected to operate with a maximum of 100 mV peak-to-peak square-wave injected noise at up to 10 MHz.

**Note** Equivalent resistance is calculated by dividing the nominal voltage by the typical RMS read/write current.

### 2.7.3 Voltage tolerance

Voltage tolerance (including noise):

- +5V ± 5%

## 2.7.4 Power management modes

The drive provides programmable power management to provide greater energy efficiency. In most systems, power management is controlled through the system setup program. The drive features the following power-management modes:

Power modes	Heads	Spindle	Buffer
Active (operating)	Tracking	Rotating	Full power
Idle, performance	Tracking	Rotating	Self refresh—low power
Idle, active	Floating	Rotating	Self refresh—low power
Idle, low power	Parked	Rotating	Self refresh—low power
Standby	Parked	Stopped	Self refresh—low power
Sleep	Parked	Stopped	Self refresh—low power

### ■ Active mode

The drive is in active mode during the read/write and seek operations.

### ■ Idle mode

The buffer remains enabled, and the drive accepts all commands and returns to active mode any time disk access is necessary.

### ■ Standby mode

The drive enters standby mode when the host sends a standby Immediate command. If the host has set the standby timer, the drive can also enter standby mode automatically after the drive has been inactive for a specifiable length of time. The standby timer delay is established using a standby or idle command. In standby mode, the drive buffer is enabled, the heads are parked and the spindle is at rest. The drive accepts all commands and returns to active mode any time disk access is necessary.

### ■ Sleep mode

The drive enters sleep mode after receiving a sleep command from the host. In sleep mode, the drive buffer is disabled, the heads are parked and the spindle is at rest. The drive leaves sleep mode after it receives a hard reset or soft reset from the host. After receiving a reset, the drive exits sleep mode and enters standby mode with all current translation parameters intact.

### ■ Idle and standby timers

Each time the drive performs an active function (read, write or seek), the standby timer is reinitialized and begins counting down from its specified delay times to zero. If the standby timer reaches zero before any drive activity is required, the drive makes a transition to standby mode. In both Idle and standby mode, the drive accepts all commands and returns to active mode when disk access is necessary.

## 2.8 Environmental Specifications

This section provides the temperature, humidity, shock, and vibration specifications for Seagate Laptop SSHD drives. Ambient temperature is defined as the temperature of the environment immediately surrounding the drive. Above 1000 feet (305 meters), the maximum temperature is derated linearly by 1°C every 1000 feet.

**Table 5: Environmental specifications**

Parameters	Operating	Non-Operating
Ambient temperature	0° to 60°C (32° to 140°F)	-40° to 70°C (-40° to 158°F)
Temperature gradient	20°C per hour (68°F per hour) max, without condensation	35°C per hour (95°F per hour) max, without condensation
Humidity	5% to 95% non-condensing (30% per hour)	5% to 95% non-condensing (30% per hour)
Wet bulb	37.7°C (99.8°F) max	40°C (104°F) max
Altitude	-304.8m to 3048m (-1000ft to 10,000ft)	-304.8m to 12,192m (-1000ft to 40,000ft)

### Note

The recommended storage period:

- 1 year under controlled conditions of 34°C 90%RH or less
- 90 days in uncontrolled storage conditions

## 2.8.1 Shock

All shock specifications assume that the drive is mounted securely with the input shock applied at the drive mounting screws. Shock may be applied in the X, Y, or Z axis.

### 2.8.1.1 Operating shock

These drives comply with the performance levels specified in this document when subjected to a maximum operating shock of 350 Gs based on half-sine shock pulses of 2ms. Shocks should not be repeated more than one time per axis

### 2.8.1.2 Nonoperating shock

The nonoperating shock level that the drive can experience without incurring physical damage or degradation in performance when subsequently put into operation is 800 Gs based on a nonrepetitive half-sine shock pulse of 2 ms duration.

The nonoperating shock level that the drive can experience without incurring physical damage or degradation in performance when subsequently put into operation is 1000 Gs based on a nonrepetitive half-sine shock pulse of 1 ms duration.

## 2.8.2 Vibration

All vibration specifications assume that the drive is mounted securely with the input vibration applied at the drive mounting screws. Vibration may be applied in the X, Y, or Z axis.

### 2.8.2.1 Operating vibration

The maximum vibration levels that the drive may experience while meeting the performance standards specified in this document are specified below.

5–200 Hz	2.0 Gs (0 to peak). Max displacement may apply below 10 Hz.
201–500 Hz	1.0 Gs (0 to peak).

### 2.8.2.2 Nonoperating vibration

The maximum nonoperating vibration levels that the drive may experience without incurring physical damage or degradation in performance when subsequently put into operation are specified below.

5–500 Hz	5.0 Gs (0 to peak). Max displacement may apply below 22 Hz.
----------	---

## 2.9 Acoustics

Drive emission of sound is measured consistent with the ECMA-74 and its referenced standards. Testing is conducted at room temperature (approximately 25°C). Emission levels are reported as the total A-weighted sound power levels for steady state, idle, and active seeks modes of operation.

**Table 6 Drive A-weighted Sound Power Levels (SWL, BA)**

Idle <sup>(1)</sup>	Performance Seek
2.2 bels (typ) 2.4 bels (max)	2.4 bels (typ) 2.6 bels (max)

1. During periods of drive idle, some offline activity may occur according to the S.M.A.R.T. specification, which may increase acoustic and power to operational levels.

### 2.9.1 Test for prominent discrete tones (PDTs)

Seagate follows the ECMA-74 standards for measurement and identification of PDTs. An exception to this process is the use of the absolute threshold of hearing. Seagate uses the lower limit for the threshold curve\* to discern tone audibility and to compensate for the inaudible components of sound prior to computation of tone ratios according to Annex D of the ECMA-74 standards.

\*Defined as the median curve given by ISO 389-7 (Tf curve) minus 10dB at all frequencies.

## 2.10 Electromagnetic Immunity

When properly installed in a representative host system, the drive operates without errors or degradation in performance when subjected to the radio frequency (RF) environment as defined in [Table 7](#).

**Table 7 Radio Frequency Environments**

Test	Description	Performance Level	Reference Standard
Electrostatic discharge	Contact, HCP, VCP: $\pm 4$ kV; Air: $\pm 8$ kV	B	EN 61000-4-2: 95
Radiated RF immunity	80 to 1,000 MHz, 3 V/m, 80% AM with 1 kHz sine 900 MHz, 3 V/m, 50% pulse modulation @ 200 Hz	A	EN 61000-4-3: 96 ENV 50204: 95
Electrical fast transient	$\pm 1$ kV on AC mains, $\pm 0.5$ kV on external I/O	B	EN 61000-4-4: 95
Surge immunity	$\pm 1$ kV differential, $\pm 2$ kV common, AC mains	B	EN 61000-4-5: 95
Conducted RF immunity	150 kHz to 80 MHz, 3 Vrms, 80% AM with 1 kHz sine	A	EN 61000-4-6: 97
Power Frequency H-field immunity	1 A/m, 50Hz/60Hz, 3 axes	A	EN 61000-4-8: 97
Voltage dips, interrupts	30% Reduction for 25 cycles >95% Reduction for 250 cycles >95%, 0.5 cycles	C C B	EN 61000-4-11: 94

## 2.11 Reliability

Nonrecoverable read errors	1 per $10^{15}$ bits read, max
Load/Unload (U/UL) 25°C, 50% relative humidity	600,000 software-controlled power on/off cycles 20,000 hard power on/off cycles
Rated workload	Average rate of <55TB/year. The MTBF specification for the drive assumes the I/O workload does not exceed the average annualized workload rate limit of 55TB/year. Workloads exceeding the annualized rate may degrade the drive MTBF and impact product reliability. The average annualized workload rate limit is in units of TB per year, or TB per 8760 power-on hours. Workload rate limit = TB transferred $\times$ (8760/recorded power-on hours).
Warranty	To determine the warranty for a specific drive, use a web browser to access the following web page: <a href="http://www.seagate.com/support/warranty-and-replacements/">http://www.seagate.com/support/warranty-and-replacements/</a> From this page, click on the "Verify Your Warranty" link. Users will be asked to provide the drive serial number, model number (or part number) and country of purchase. The system will display the warranty information for the drive.



## 2.12 Agency Certification

### 2.12.1 Safety certification

These products are certified to meet the requirements of UL60950-1, CSA60950-1 and EN60950 and so marked as to the certify agency.

### 2.12.2 Electromagnetic Compatibility (EMC)

Hard drives that display the CE mark comply with the European Union (EU) requirements specified in the Electromagnetic Compatibility Directive (2004/108/EC) as put into place 20 July 2007. Testing is performed to the levels specified by the product standards for Information Technology Equipment (ITE). Emission levels are defined by EN 55022, Class B and the immunity levels are defined by EN 55024.

Drives are tested in representative end-user systems. Although CE-marked Seagate drives comply with the directives when used in the test systems, we cannot guarantee that all systems will comply with the directives. The drive is designed for operation inside a properly designed enclosure, with properly shielded I/O cable (if necessary) and terminators on all unused I/O ports. Computer manufacturers and system integrators should confirm EMC compliance and provide CE marking for their products.

#### Korean RRL

If these drives have the Korean Communications Commission (KCC) logo, they comply with paragraph 1 of Article 11 of the Electromagnetic Compatibility control Regulation and meet the Electromagnetic Compatibility (EMC) Framework requirements of the Radio Research Laboratory (RRL) Communications Commission, Republic of Korea.

These drives have been tested and comply with the Electromagnetic Interference/Electromagnetic Susceptibility (EMI/EMS) for Class B products. Drives are tested in a representative, end-user system by a Korean-recognized lab.

- Certificate number: IKCC-REM-STX-LaptopSSHD
- Trade name or applicant: Seagate Technology LLC
- Certificate date: 14 December, 2012
- Manufacturer/nationality: USA, Singapore and China

#### Australian C-Tick (N176)

If these models have the C-Tick marking, they comply with the Australia/New Zealand Standard AS/NZS3548 1995 and meet the Electromagnetic Compatibility (EMC) Framework requirements of the Australian Communication Authority (ACA).

### 2.12.3 FCC verification

These drives are intended to be contained solely within a personal computer or similar enclosure (not attached as an external device). As such, each drive is considered to be a subassembly even when it is individually marketed to the customer. As a subassembly, no Federal Communications Commission verification or certification of the device is required.

Seagate has tested this device in enclosures as described above to ensure that the total assembly (enclosure, disk drive, motherboard, power supply, etc.) does comply with the limits for a Class B computing device, pursuant to Subpart J, Part 15 of the FCC rules. Operation with noncertified assemblies is likely to result in interference to radio and television reception.

**Radio and television interference.** This equipment generates and uses radio frequency energy and if not installed and used in strict accordance with the manufacturer's instructions, may cause interference to radio and television reception.

This equipment is designed to provide reasonable protection against such interference in a residential installation. However, there is no guarantee that interference will not occur in a particular installation. If this equipment does cause interference to radio or television, which can be determined by turning the equipment on and off, users are encouraged to try one or more of the following corrective measures:

- Reorient the receiving antenna.
- Move the device to one side or the other of the radio or TV.
- Move the device farther away from the radio or TV.
- Plug the computer into a different outlet so that the receiver and computer are on different branch outlets.

If necessary, users should consult the dealer or an experienced radio/television technician for additional suggestions. Users may find helpful the following booklet prepared by the Federal Communications Commission: *How to Identify and Resolve Radio-Television Interference Problems*. This booklet is available from the Superintendent of Documents, U.S. Government Printing Office, Washington, DC 20402. Refer to publication number 004-000-00345-4.

## 2.13 Environmental Protection

Seagate designs its products to meet environmental protection requirements worldwide, including regulations restricting certain chemical substances.

### 2.13.1 European Union Restriction of Hazardous Substances (RoHS) Directive

The European Union Restriction of Hazardous Substances (RoHS) Directive, restricts the presence of chemical substances, including Lead, Cadmium, Mercury, Hexavalent Chromium, PBB and PBDE, in electronic products, effective July 2006. This drive is manufactured with components and materials that comply with the RoHS Directive.

### 2.13.2 China Restriction of Hazardous Substances (RoHS) Directive 中国限制危险物品的指令

This product has an Environmental Protection Use Period (EPUP) of 20 years. The following table contains information mandated by China's "Marking Requirements for Control of Pollution Caused by Electronic Information Products" Standard.

该产品具有20年的环境保护使用周期（EPUP）。下表包含了中国“电子产品所导致的污染的控制的记号要求”所指定的信息。



Name of Parts 部件名称	Toxic or Hazardous Substances or Elements有毒有害物质或元素					
	Lead 铅 (Pb)	Mercury 汞 (Hg)	Cadmium 镉 (Cd)	Hexavalent Chromium 六价铬 (Cr6+)	Polybrominated Diphenyl 多溴联苯 (PBB)	Polybrominated Diphenyl Ether 多溴二苯醚 (PBDE)
PCBA	X	O	O	O	O	O
HDA	X	O	O	O	O	O

"O" indicates the hazardous and toxic substance content of the part (at the homogenous material level) is lower than the threshold defined by the China RoHS MCV Standard.

“O”表示该部件（于同类物品程度上）所含的危险和有毒物质低于中国RoHS MCV标准所定义的门槛值。

"X" indicates the hazardous and toxic substance content of the part (at the homogenous material level) is over the threshold defined by the China RoHS MCV Standard.

“X”表示该部件（于同类物品程度上）所含的危险和有毒物质超出中国RoHS MCV标准所定义的门槛值。

## 2.14 Corrosive Environment

Seagate electronic drive components pass accelerated corrosion testing equivalent to 10 years exposure to light industrial environments containing sulfurous gases, chlorine and nitric oxide, classes G and H per ASTM B845. However, this accelerated testing cannot duplicate every potential application environment.

Users should use caution exposing any electronic components to uncontrolled chemical pollutants and corrosive chemicals as electronic drive component reliability can be affected by the installation environment. The silver, copper, nickel and gold films used in Seagate products are especially sensitive to the presence of sulfide, chloride, and nitrate contaminants. Sulfur is found to be the most damaging. In addition, electronic components should never be exposed to condensing water on the surface of the printed circuit board assembly (PCBA) or exposed to an ambient relative humidity greater than 95%. Materials used in cabinet fabrication, such as vulcanized rubber, that can outgas corrosive compounds should be minimized or eliminated. The useful life of any electronic equipment may be extended by replacing materials near circuitry with sulfide-free alternatives.

## 3.0 Configuring and Mounting the Drive

This section contains the specifications and instructions for configuring and mounting the drive.

### 3.1 Handling and Static-Discharge Precautions

After unpacking, and before installation, the drive may be exposed to potential handling and electrostatic discharge (ESD) hazards. Observe the following standard handling and static-discharge precautions.

<b>CAUTION</b>	<ul style="list-style-type: none"> <li>• Keep the drive in the electrostatic discharge (ESD) bag until users are ready for installation to limit the drive's exposure to ESD.</li> <li>• Before handling the drive, put on a grounded wrist strap, or ground oneself frequently by touching the metal chassis of a computer that is plugged into a grounded outlet. Wear a grounded wrist strap throughout the entire installation procedure.</li> <li>• Handle the drive by its edges or frame <i>only</i>.</li> <li>• The drive is extremely fragile—handle it with care. Do not press down on the drive top cover.</li> <li>• Always rest the drive on a padded, antistatic surface until users mount it in the computer.</li> <li>• Do not touch the connector pins or the printed circuit board.</li> <li>• Do not remove the factory-installed labels from the drive or cover them with additional labels. Removal voids the warranty. Some factory-installed labels contain information needed to service the drive. Other labels are used to seal out dirt and contamination.</li> </ul>
----------------	--

### 3.2 Configuring the Drive

Each drive on the Serial ATA interface connects in a point-to-point configuration with the Serial ATA host adapter. There is no master/slave relationship because each drive is considered a master in a point-to-point relationships. If two drives are attached on one Serial ATA host adapter, the host operating system views the two devices as if they were both “masters” on two separate ports. Both drives behave as if they are Device 0 (master) devices.

#### 3.2.1 Serial ATA Cables and Connectors

The Serial ATA interface cable consists of four conductors in two differential pairs, plus three ground connections. The cable size may be 30 to 26 AWG with a maximum length of one meter (39.37 in). Refer to [Table 8](#) for connector pin definitions. Either end of the SATA signal cable can be attached to the drive or host.

For direct backplane connection, the drive connectors are inserted directly into the host receptacle. The drive and the host receptacle incorporate features that enable the direct connection to be hot pluggable and blind mateable. For installations which require cables, users can connect the drive as shown in [Figure 2](#).

**Figure 2 Attaching SATA Cabling**

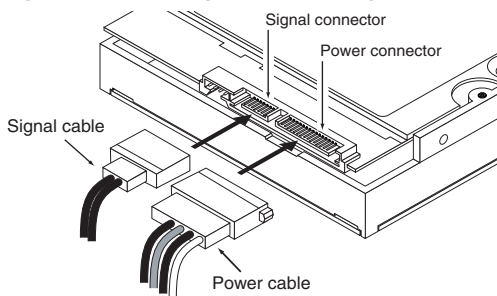

Each cable is keyed to ensure correct orientation. Seagate Laptop SSHD SATA drives support latching SATA connectors.

### 3.3 Drive Mounting

Users can mount the drive in any orientation using four screws in the side-mounting holes or four screws in the bottom-mounting holes. Refer to **Figure 3** for drive mounting dimensions. Follow these important mounting precautions when mounting the drive:

- Allow a minimum clearance of 0.030 in (0.76 mm) around the entire perimeter of the drive for cooling.
- Use only M3 x 0.5 mounting screws.
- Do not overtighten the mounting screws. Maximum torque: 4.0 in-lb (0.4519 N-m).
- Four (4) threads (0.080 in, 2.032 mm) minimum screw engagement recommended.
- Avoid excessive drive distortion when mounting. Refer to the following specifications for stiffness/deflection information:

Top cover stiffness/deflection	
Operating: no performance degradation, emitted noise, mechanical damage, or hard errors	10 mm probe: 1.02kgf or 5 mm probe: 0.92kgf
Non-operating: no hard errors	20 mm probe: 2.0kgf at any point of top cover 20 mm probe: 15.0kgf at top cover edges only

**Figure 3 Mounting Dimensions (for standard models)**

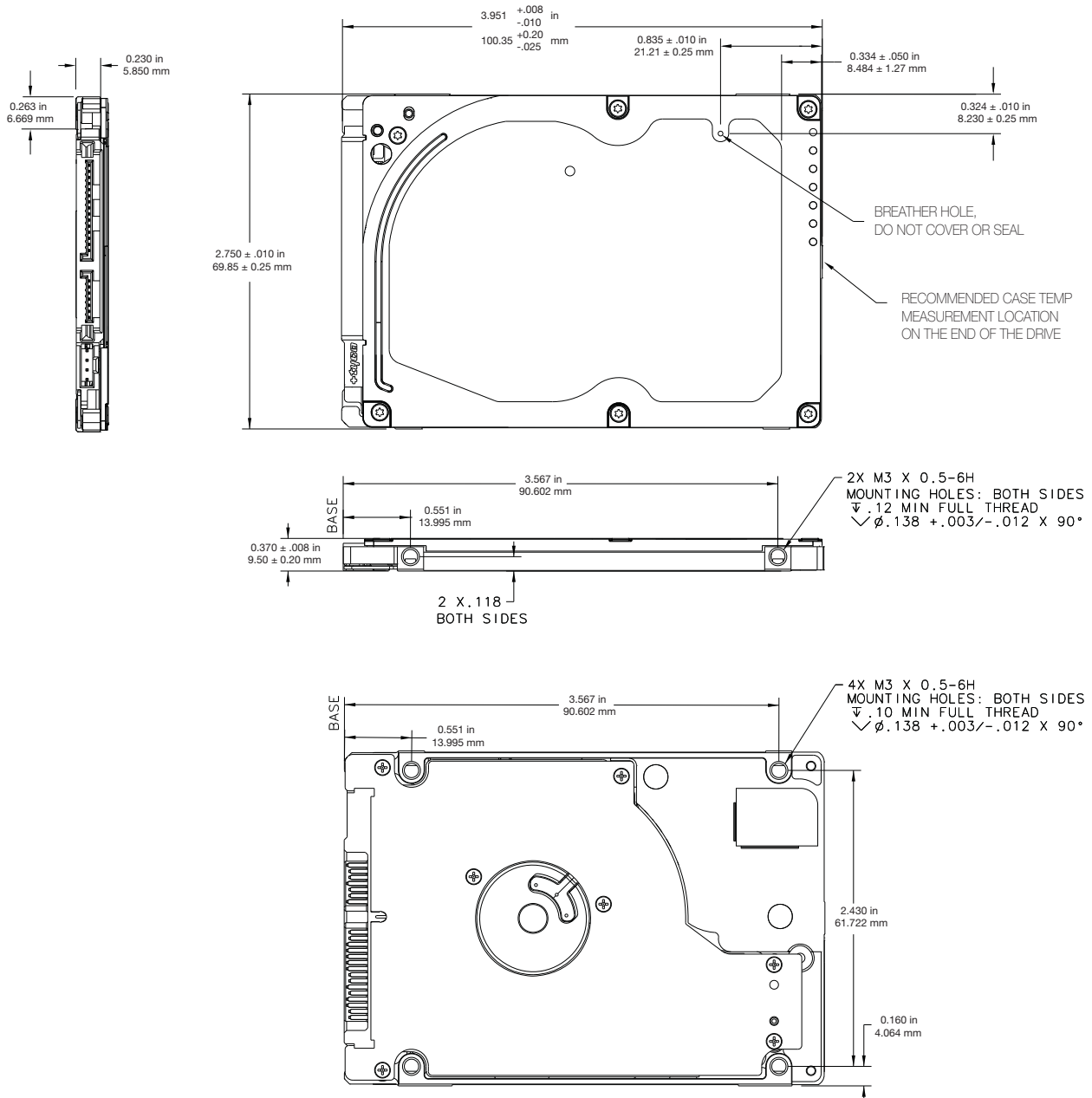

**Note** For reference only. May not represent actual drive.

## 4.0 About FIPS

The Federal Information Processing Standard (FIPS) Publication 140-2, FIPS PUB 140-2, is a U.S. government computer security standard used to accredit cryptographic modules. It is titled “Security Requirements for Cryptographic Modules”. The initial publication was on May 25, 2001 and was last updated December 3, 2002.

### Purpose.

The National Institute of Standards and Technology (NIST) issued the FIPS 140 Publication Series to coordinate the requirements and standards for cryptography modules that include both hardware and software components.

Federal Information Processing Standard (FIPS) 140-2 Level 2 Certification requires drives to go through government agencies certifications to add requirements for physical tamper-evidence and role-based authentication. For more information, refer to 'Security Rules' section in the 'Security Policy' document uploaded on the NIST website. To reference the product certification visit:

<http://csrc.nist.gov/groups/STM/cmvp/documents/140-1/1401vend.htm>, and search for “Seagate”.

### Security Level 2.

Security Level 2 enhances the physical security mechanisms of a Security Level 1 cryptographic module by adding the requirement for tamper-evidence, which includes the use of tamper-evident coatings or seals on removable covers of the module. Tamper-evident coatings or seals are placed on a cryptographic module so that the coating or seal must be broken to attain physical access to the critical security parameters (CSP) within the module. Tamper-evident seals (example shown in Figure 5, page 19) are placed on covers to protect against unauthorized physical access. In addition Security Level 2 requires, at a minimum, role-based authentication in which a cryptographic module authenticates the authorization of an operator to assume a specific role and perform a corresponding set of services.

**Figure 4 Example of FIPS tamper evidence labels.**



**Note** For reference only. May not represent actual drive.



## 5.0 About (SED) Self-Encrypting Drives

Self-encrypting drives (SEDs) offer encryption and security services for the protection of stored data, commonly known as "protection of data at rest." These drives are compliant with the Trusted Computing Group (TCG) Opal Storage Specifications as detailed in the following:

Trusted Computing Group (TCG) Documents (apply to Self-Encrypting Drive models only)  
TCG Storage Architecture Core Specification, Version 2.0  
TCG Storage Security Subsystem Class Opal Specification, Version 2.0  
(see [www.trustedcomputinggroup.org](http://www.trustedcomputinggroup.org))

In case of conflict between this document and any referenced document, this document takes precedence.

The Trusted Computing Group (TCG) is an organization sponsored and operated by companies in the computer, storage and digital communications industry. Seagate's SED models comply with the standards published by the TCG.

To use the security features in the drive, the host must be capable of constructing and issuing the following two SATA commands:

- Trusted Send
- Trusted Receive

These commands are used to convey the TCG protocol to and from the drive in their command payloads.

### 5.1 Data Encryption

Encrypting drives use one inline encryption engine for each drive employing AES-256 data encryption in Cipher Block Chaining (CBC) mode to encrypt all data prior to being written on the media and to decrypt all data as it is read from the media. The encryption engine is always in operation and cannot be disabled.

The 32-byte Data Encryption Key (DEK) is a random number which is generated by the drive, never leaves the drive, and is inaccessible to the host system. The DEK is itself encrypted when it is stored on the media and when it is in volatile temporary storage (DRAM) external to the encryption engine. A unique data encryption key is used for each of the drive's possible 16 data bands (see [Section 5.5, Data Bands](#)).

### 5.2 Controlled Access

The drive has two security providers (SPs) called the "Admin SP" and the "Locking SP." These act as gatekeepers to the drive security services. Security-related commands will not be accepted unless they also supply the correct credentials to prove the requester is authorized to perform the command.

#### 5.2.1 Admin SP

The Admin SP allows the drive's owner to enable or disable firmware download operations (see [Section 5.4, Drive Locking](#)). Access to the Admin SP is available using the SID (Secure ID) password or the MSID (Manufacturers Secure ID) password.

#### 5.2.2 Locking SP

The Locking SP controls read/write access to the media and the cryptographic erase feature. Access to the Locking SP is available using the Admin or User passwords.

#### 5.2.3 Default password

When the drive is shipped from the factory, all passwords are set to the value of MSID. This 32-byte random value can only be read by the host electronically over the interface. After receipt of the drive, it is the responsibility of the owner to use the default MSID password as the authority to change all other passwords to unique owner-specified values.

#### 5.2.4 ATA Enhanced Security

The drive can utilize the system's BIOS through the ATA Security API for cases that do not require password management and additional security policies.

Furthermore, the drive's ATA Security Erase Unit command shall support both Normal and Enhanced Erase modes with the following modifications/additions:

**Normal Erase:** Normal erase feature shall be performed by changing the Data Encryption Key (DEK) of the drive, followed by an overwrite operation that repeatedly writes a single sector containing random data to the entire drive. This write operation bypasses the media encryption. On reading back the overwritten sectors, the host will receive a decrypted version, using the new DEK of the random data sector (the returned data will not match what was written).

**Enhanced Erase:** Enhanced erase shall be performed by changing the Data Encryption Key of the drive.

### 5.3 Random Number Generator (RNG)

The drive has a 32-byte hardware RNG that it uses to derive encryption keys or, if requested to do so, to provide random numbers to the host for system use, including using these numbers as Authentication Keys (passwords) for the drive's Admin and Locking SPs.

### 5.4 Drive Locking

In addition to changing the passwords, as described in [Section 5.2.3, Default password](#), the owner should also set the data access controls for the individual bands.

The variable "LockOnReset" should be set to "PowerCycle" to ensure that the data bands will be locked if power is lost. In addition "ReadLockEnabled" and "WriteLockEnabled" must be set to true in the locking table in order for the bands "LockOnReset" setting of "PowerCycle" to actually lock access to the band when a "PowerCycle" event occurs. This scenario occurs if the drive is removed from its cabinet. The drive will not honor any data read or write requests until the bands have been unlocked. This prevents the user data from being accessed without the appropriate credentials when the drive has been removed from its cabinet and installed in another system.

### 5.5 Data Bands

When shipped from the factory, the drive is configured with a single data band called Band 0 (also known as the Global Data Band) which comprises LBA 0 through LBA max. The host may allocate additional bands (Band1 to Band15) by specifying a start LBA and an LBA range. The real estate for this band is taken from the Global Band.

Data bands cannot overlap but they can be sequential with one band ending at LBA (x) and the next beginning at LBA (x+1).

Each data band has its own drive-generated encryption key. The host may change the Encryption Key (see [Section 5.6, Cryptographic Erase](#)) or the password when required. The bands should be aligned to 4K LBA boundaries.

### 5.6 Cryptographic Erase

A significant feature of SEDs is the ability to perform a cryptographic erase. This involves the host telling the drive to change the data encryption key for a particular band. Once changed, the data is no longer recoverable since it was written with one key and will be read using a different key. Since the drive overwrites the old key with the new one, and keeps no history of key changes, the user data can never be recovered. This is tantamount to an instantaneous data erase and is very useful if the drive is to be scrapped or redispositioned.

### 5.7 Authenticated Firmware Download

In addition to providing a locking mechanism to prevent unwanted firmware download attempts, the drive also only accepts download files which have been cryptographically signed by the appropriate Seagate Design Center.

Three conditions must be met before the drive will allow the download operation:

1. The download must be an SED file. A standard (base) drive (non-SED) file will be rejected.
2. The download file must be signed and authenticated.
3. As with a non-SED drive, the download file must pass the acceptance criteria for the drive. For example it must be applicable to the correct drive model, and have compatible revision and customer status.

### 5.8 Power Requirements

The standard drive models and the SED drive models have identical hardware, however the security and encryption portion of the drive controller ASIC is enabled and functional in the SED models. This represents a small additional drain on the 5V supply of about

30mA and a commensurate increase of about 150mW in power consumption. There is no additional drain on the 12V supply. See the tables in [Section 2.7, Power Specifications](#) for power requirements on the standard (non-SED) drive models.

### 5.9 Supported Commands

The SED models support the following two commands in addition to the commands supported by the standard (non-SED) models as listed in [Table 9](#):

- Trusted Send
- Trusted Receive

### 5.10 RevertSP

SED models will support the RevertSP feature which erases all data in all bands on the device and returns the contents of all SPs (Security Providers) on the device to their original factory state. In order to execute the RevertSP method the unique PSID (Physical Secure ID) printed on the drive label must be provided. PSID is not electronically accessible and can only be manually read from the drive label or scanned in via the 2D barcode.

## 6.0 Serial ATA (SATA) Interface

These drives use the industry-standard Serial ATA interface that supports FIS data transfers. It supports ATA programmed input/output (PIO) modes 0–4; multiword DMA modes 0–2, and Ultra DMA modes 0–6. The drive also supports the use of the IORDY signal to provide reliable high-speed data transfers.

For detailed information about the Serial ATA interface, refer to the *Serial ATA: High Speed Serialized AT Attachment* specification.

### 6.1 Hot-Plug Compatibility

Seagate Laptop SSHD SATA drives incorporate connectors which enable users to hot plug these drives in accordance with the Serial ATA: High Speed Serialized AT Attachment specification revision 2.0. This specification can be downloaded from [www.serialata.org](http://www.serialata.org). This device requires a COMRESET from the host after a hotplug event.

### 6.2 Serial ATA Device Plug Connector Pin Definitions

**Table 8** summarizes the signals on the Serial ATA interface and power connectors. Refer to the **Notes** below.

**Table 8 Serial ATA Connector Pin Definitions**

Segment	Pin	Function	Definition
Signal	S1	Ground	2nd mate
	S2	A+	Differential signal pair A from Phy
	S3	A-	
	S4	Ground	2nd mate
	S5	B-	Differential signal pair B from Phy
	S6	B+	
	S7	Ground	2nd mate
<b>Key and spacing separate signal and power segments</b>			
Power	P1	V <sub>33</sub>	3.3V power
	P2	V <sub>33</sub>	3.3V power
	P3	V <sub>33</sub>	3.3V power, pre-charge, 2nd mate
	P4	Ground	1st mate
	P5	Ground	2nd mate
	P6	Ground	2nd mate
	P7	V <sub>5</sub>	5V power, pre-charge, 2nd mate
	P8	V <sub>5</sub>	5V power
	P9	V <sub>5</sub>	5V power
	P10	Ground	2nd mate
	P11	Ground or LED signal	If grounded, drive does not use deferred spin
	P12	Ground	1st mate
	P13	V <sub>12</sub>	12V power, pre-charge, 2nd mate
	P14	V <sub>12</sub>	12V power
	P15	V <sub>12</sub>	12V power

#### Notes

- All pins are in a single row, with a 1.27 mm (0.050 in) pitch.
- The comments on the mating sequence apply to the case of backplane blindmate connector only. In this case, the mating sequences are:
  - the ground pins P4 and P12.
  - the pre-charge power pins and the other ground pins.
  - the signal pins and the rest of the power pins.
- There are three power pins for each voltage. One pin from each voltage is used for pre-charge when installed in a blind-mate backplane configuration.
- All used voltage pins (V<sub>x</sub>) must be terminated.



### 6.3 Supported ATA Commands

**Table 9** lists Serial ATA standard commands that the drive supports. For a detailed description of the ATA commands, refer to the *Serial ATA International Organization: Serial ATA* (Revision 2.6). Refer to [www.sata-io.org](http://www.sata-io.org).

Refer to **S.M.A.R.T. commands** on page 31 for details and subcommands used in the S.M.A.R.T. implementation.

**Table 9 Supported ATA commands**

ATA-standard commands names	Command code (in hex)	
Device Configuration Restore	B1h/C0h	
Device Configuration Freeze Lock	B1h/C1h	
Device Configuration Identify	B1h/C2h	
Device Configuration Set	B1h/C3h	
Download Microcode	92h	
Execute Device Diagnostics	90h	
Flush Cache	E7h	
Flush Cache Extended	EAh	
Identify Device	ECh	
Initialize Device Parameters	91h	
Read Buffer	E4h	
Read DMA	C8h	
Read DMA Extended	25h	
Read DMA without Retries	C9h	
Read Long with Retries	22h	
Read Long without Retries	23h	
Read Multiple	C4h	
Read Multiple Extended	29h	
Read Native Max Address	F8h	
Read Native Max Address Extended	27h	
Read Sectors	20h	
Read Sectors Extended	24h	
Read Sectors without Retries	21h	
Read Verify Sectors	40h	
Read Verify Sectors Extended	42h	
Read Verify Sectors without Retries	41h	
Seek	70h	
Set Features	EFh	
Set Max Address	F9h	
<b>Note:</b> Individual Set Max commands are identified by the value placed in the Set Max Features register as defined to the right.	Address: Password: Lock: Unlock: Freeze Lock:	00 <sub>H</sub> 01 <sub>H</sub> 02 <sub>H</sub> 03 <sub>H</sub> 04 <sub>H</sub>
Set Max Address Ext	37h	
Set Multiple Mode	C6h	
S.M.A.R.T. Disable Operations	B0h/D9h	
S.M.A.R.T. Enable/Disable Autosave	B0h/D2h	

**Table 9 Supported ATA commands**

<b>ATA-standard commands names</b>	<b>Command code (in hex)</b>
S.M.A.R.T. Enable Operations	B0h/D8h
S.M.A.R.T. Enable/Disable Auto Offline	B0h/DBh
S.M.A.R.T. Enable One Attribute Modification	B0h/E0h
S.M.A.R.T. Execute Offline	B0h/D4h
S.M.A.R.T. Free Fall Protection Host Interface	FEh
S.M.A.R.T. Read Attribute Thresholds	B0h/D1h
S.M.A.R.T. Read Data	B0h/D0h
S.M.A.R.T. Read Log Sector	B0h/D5h
S.M.A.R.T. Return Status	B0h/DAh
S.M.A.R.T. Save Attribute Values	B0h/D3h
S.M.A.R.T. Write Attribute Thresholds	B0h/D7h
S.M.A.R.T. Write Attribute Values	B0h/E1h
S.M.A.R.T. Write Log Sector	B0h/D6h
Write Buffer	E8h
Write DMA	CAh
Write DMA Extended	35h
Write DMA without Retries	CBh
Write Long with Retries	32h
Write Long without Retries	33h
Write Multiple	C5h
Write Multiple Extended	39h
Write Sectors	30h, 31h
Write Sectors Extended	34h
<b>ATA-standard power-management commands</b>	
Check Power Mode	E5h
Idle	E3h
Idle Immediate	E1h
Sleep	E6h
Standby	E2h
Standby Immediate	E0h
<b>ATA-standard security commands</b>	
Security Set Password	F1h
Security Unlock	F2h
Security Erase Prepare	F3h
Security Erase Unit	F4h
Security Freeze Lock	F5h
Security Disable Password	F6h

### 6.3.1 Identify Device command

The Identify Device command (command code EC<sub>H</sub>) transfers information about the drive to the host following power up. The data is organized as a single 512-byte block of data, whose contents are shown in [Table 10](#). All reserved bits or words should be set to zero. Parameters listed with an “x” are drive-specific or vary with the state of the drive. Refer to [Drive Specifications](#) on page 8 for default parameter settings.

The following commands contain drive-specific features that may not be included in the Serial ATA specification.

**Table 10 Identify Device command**

Word	Description	Value
0	Configuration information: • Bit 15: 0 = ATA; 1 = ATAPI • Bit 7: removable media • Bit 6: removable controller • Bit 0: reserved	0C5A <sub>H</sub>
1	Number of logical cylinders	16,383
2	Specific configuration	C837 <sub>H</sub>
3	Number of logical heads	16
4	Retired	0000 <sub>H</sub>
5	Retired	0000 <sub>H</sub>
6	Number of logical sectors per logical track: 63	003F <sub>H</sub>
7–9	Retired	0000 <sub>H</sub>
10–19	Serial number: (20 ASCII characters, 0000 <sub>H</sub> = none)	ASCII
20	Retired	0000 <sub>H</sub>
21	Retired	8000 <sub>H</sub>
22	Obsolete	0004 <sub>H</sub>
23–26	Firmware revision: (8 ASCII character string, padded with blanks to end of string)	x.xx
27–46	Drive model number: (40 ASCII characters, padded with blanks to end of string)	ST1000LX000 ST1000LX001 ST1000LM014 ST1000LM015 ST1000LM028 ST750LM000
47	(Bits 7–0) Maximum sectors per interrupt on Read multiple and Write multiple (16)	8010 <sub>H</sub>
48	Trusted Computing Feature set options	0000 <sub>H</sub>
49	Standard Standby timer, IORDY supported and may be disabled	2F00 <sub>H</sub>
50	Capabilities	4000 <sub>H</sub>
51	PIO data-transfer cycle timing mode	0200 <sub>H</sub>
52	Retired	0200 <sub>H</sub>
53	Words 54–58, 64–70 and 88 are valid	0007 <sub>H</sub>
54	Number of current logical cylinders	xxxx <sub>H</sub>
55	Number of current logical heads	xxxx <sub>H</sub>
56	Number of current logical sectors per logical track	xxxx <sub>H</sub>
57–58	Current capacity in sectors	xxxx <sub>H</sub>

**Table 10 Identify Device command**

Word	Description	Value
59	Number of sectors transferred during a Read Multiple or Write Multiple command	xxxx <sub>H</sub>
60–61	Total number of user-addressable sectors This field contains a value that is one greater than the total number of user-addressable sectors. The maximum value that shall be placed in this field is 0FFFFFFF <sub>H</sub> . The 0FFFFFFF <sub>H</sub> value applies to all capacities over 137GB (see Section 2.1 for related information).	ST1000LX000 = 0FFFFFFF <sub>H</sub> ST1000LX001 = 0FFFFFFF <sub>H</sub> ST1000LM014 = 0FFFFFFF <sub>H</sub> ST1000LM015 = 0FFFFFFF <sub>H</sub> ST1000LM028 = 0FFFFFFF <sub>H</sub> ST750LM000 = 0FFFFFFF <sub>H</sub>
62	Retired	0000 <sub>H</sub>
63	Multiword DMA active and modes supported (see note following this table)	xx07 <sub>H</sub>
64	Advanced PIO modes supported (modes 3 and 4 supported)	0003 <sub>H</sub>
65	Minimum multiword DMA transfer cycle time per word (120 ns)	0078 <sub>H</sub>
66	Recommended multiword DMA transfer cycle time per word (120 ns)	0078 <sub>H</sub>
67	Minimum PIO cycle time without IORDY flow control (240 ns)	0078 <sub>H</sub>
68	Minimum PIO cycle time with IORDY flow control (120 ns)	0078 <sub>H</sub>
69–74	ATA-reserved	0000 <sub>H</sub>
75	Queue depth	001F <sub>H</sub>
76	Serial ATA capabilities	0D06 <sub>H</sub>
77	ATA-reserved	0000 <sub>H</sub>
78	Serial ATA features supported	0048 <sub>H</sub>
79	Serial ATA features enabled	0048 <sub>H</sub>
80	Major version number	01F0 <sub>H</sub>
81	Minor version number	0029 <sub>H</sub>
82	Command sets supported	746B <sub>H</sub>
83	Command sets supported	7D69 <sub>H</sub>
84	Command sets support extension	61E3 <sub>H</sub>
85	Command sets enabled	7469
86	Command sets enabled	BC49 <sub>H</sub>
87	Command sets enable extension	61E3 <sub>H</sub>
88	Ultra DMA support and current mode (see note following this table)	xx7F <sub>H</sub>
89	Security erase time	xxxx <sub>H</sub>
90	Enhanced security erase time	xxxx <sub>H</sub>
91	Current APM values	8080 <sub>H</sub>
92	Master password revision code	FFFE <sub>H</sub>
93	Hardware reset value (see description following this table)	xxxx <sub>H</sub>
94	Auto acoustic management setting	xxxx <sub>H</sub>
95	Stream Min. Request Size	0000 <sub>H</sub>

**Table 10 Identify Device command**

Word	Description	Value
96	Streaming Transfer Time - DMA	0000 <sub>H</sub>
97	Streaming Access Latency - DMA and PIO	0000 <sub>H</sub>
98-99	Streaming Performance Granularity	0000 <sub>H</sub>
100-103	Total number of user-addressable LBA sectors available (see Section 3.2 for related information) These words are required for drives that support the 48-bit addressing feature. Maximum value: 0000FFFFFFFF <sub>H</sub> .	ST1000LX000 = 1,953,525,168 ST1000LX001 = 1,953,525,168 ST1000LM014 = 1,953,525,168 ST1000LM015 = 1,953,525,168 ST1000LM028 = 1,953,525,168 ST750LM000 = 1,465,149,168
104	Streaming Transfer Time - PIO	0000 <sub>H</sub>
105	Reserved	0000 <sub>H</sub>
106	Physical sector size / Logical sector size	6003 <sub>H</sub>
107	Seagate reserved	0000 <sub>H</sub>
108-111	The mandatory value of the world wide name (WWN) for the drive. <b>NOTE:</b> This field is valid if word 84, bit 8 is set to 1 indicating 64-bit WWN support.	Each drive will have a unique value.
112-118	ATA-reserved	0000 <sub>H</sub>
119	Free Fall Protection support (bit 5)	1 = Free Fall Protection supported 0 = Free Fall Protection not supported
120	Free Fall Protection enable/disable (bit 5)	1 = Free Fall Protection feature is enabled 0 = Free Fall Protection feature is disabled
121-127	ATA-reserved	0000 <sub>H</sub>
128	Security status	0021 <sub>H</sub>
129-159	Seagate-reserved	xxxx <sub>H</sub>
160-221	ATA-reserved	0000 <sub>H</sub>
222	Transport major version number	101F <sub>H</sub>
223-254	ATA-reserved	0000 <sub>H</sub>
255	Integrity word	xxA5 <sub>H</sub>

**Note** See the bit descriptions below for words 63, 88 and 93 of the Identify Drive data.

**Table 11 Bit Descriptions**

Description (if bit is set to 1)	
Bit	Word 63
0	Multiword DMA mode 0 is supported.
1	Multiword DMA mode 1 is supported.
2	Multiword DMA mode 2 is supported.
8	Multiword DMA mode 0 is currently active.
9	Multiword DMA mode 1 is currently active.
10	Multiword DMA mode 2 is currently active.

**Table 11 Bit Descriptions (continued)**

<b>Bit</b>	<b>Word 88</b>
0	Ultra DMA mode 0 is supported.
1	Ultra DMA mode 1 is supported.
2	Ultra DMA mode 2 is supported.
3	Ultra DMA mode 3 is supported.
4	Ultra DMA mode 4 is supported.
5	Ultra DMA mode 5 is supported.
6	Ultra DMA mode 6 is supported.
8	Ultra DMA mode 0 is currently active.
9	Ultra DMA mode 1 is currently active.
10	Ultra DMA mode 2 is currently active.
11	Ultra DMA mode 3 is currently active.
12	Ultra DMA mode 4 is currently active.
13	Ultra DMA mode 5 is currently active.
14	Ultra DMA mode 6 is currently active.
<b>Bit</b>	<b>Word 93</b>
13	1 = 80-conductor cable detected, CBLID above VIH 0 = 40-conductor cable detected, CBLID below VIL

### 6.3.2 Set Features command

This command controls the implementation of various features that the drive supports. When the drive receives this command, it sets BSY, checks the contents of the Features register, clears BSY and generates an interrupt. If the value in the register does not represent a feature that the drive supports, the command is aborted. Power-on default has the read look-ahead and write caching features enabled.

The acceptable values for the Features register are defined as follows:

**Table 12 Set Features command values**

02 <sub>H</sub>	Enable write cache ( <i>default</i> ).
03 <sub>H</sub>	Set transfer mode (based on value in Sector Count register). Sector Count register values:  00 <sub>H</sub> Set PIO mode to default (PIO mode 2). 01 <sub>H</sub> Set PIO mode to default and disable IORDY (PIO mode 2). 08 <sub>H</sub> PIO mode 0 09 <sub>H</sub> PIO mode 1 0A <sub>H</sub> PIO mode 2 0B <sub>H</sub> PIO mode 3 0C <sub>H</sub> PIO mode 4 ( <i>default</i> ) 20 <sub>H</sub> Multiword DMA mode 0 21 <sub>H</sub> Multiword DMA mode 1 22 <sub>H</sub> Multiword DMA mode 2 40 <sub>H</sub> Ultra DMA mode 0 41 <sub>H</sub> Ultra DMA mode 1 42 <sub>H</sub> Ultra DMA mode 2 43 <sub>H</sub> Ultra DMA mode 3 44 <sub>H</sub> Ultra DMA mode 4 45 <sub>H</sub> Ultra DMA mode 5 46 <sub>H</sub> Ultra DMA mode 6
55 <sub>H</sub>	Disable read look-ahead (read cache) feature.
82 <sub>H</sub>	Disable write cache
AA <sub>H</sub>	Enable read look-ahead (read cache) feature ( <i>default</i> ).
C1 <sub>H</sub>	Disable the Free Fall Protection feature (41 <sub>H</sub> above enables the Free Fall Protection feature)
F1 <sub>H</sub>	Report full capacity available

**Note** At power-on, or after a hardware or software reset, the default values of the features are as indicated above

### 6.3.3 S.M.A.R.T. commands

S.M.A.R.T. provides near-term failure prediction for disk drives. When S.M.A.R.T. is enabled, the drive monitors predetermined drive attributes that are susceptible to degradation over time. If self-monitoring determines that a failure is likely, S.M.A.R.T. makes a status report available to the host. Not all failures are predictable. S.M.A.R.T. predictability is limited to the attributes the drive can monitor. For more information on S.M.A.R.T. commands and implementation, see the *Draft ATA-5 Standard*.

SeaTools diagnostic software activates a built-in drive self-test (DST S.M.A.R.T. command for D4<sub>H</sub>) that eliminates unnecessary drive returns. The diagnostic software ships with all new drives and is also available at: <http://www.seagate.com/support/downloads/seatools/>.

This drive is shipped with S.M.A.R.T. features disabled. Users must have a recent BIOS or software package that supports S.M.A.R.T. to enable this feature. The table below shows the S.M.A.R.T. command codes that the drive uses.

**Table 13 S.M.A.R.T. Commands**

Code in features register	S.M.A.R.T. command
D0 <sub>H</sub>	S.M.A.R.T. Read Data
D2 <sub>H</sub>	S.M.A.R.T. Enable/Disable Attribute Autosave
D3 <sub>H</sub>	S.M.A.R.T. Save Attribute Values
D4 <sub>H</sub>	S.M.A.R.T. Execute Off-line Immediate (runs DST)
D5 <sub>H</sub>	S.M.A.R.T. Read Log Sector
D6 <sub>H</sub>	S.M.A.R.T. Write Log Sector
D8 <sub>H</sub>	S.M.A.R.T. Enable Operations
D9 <sub>H</sub>	S.M.A.R.T. Disable Operations
DA <sub>H</sub>	S.M.A.R.T. Return Status

**Note**

If an appropriate code is not written to the Features Register, the command is aborted and 0x04 (abort) is written to the Error register.





**Seagate Technology LLC**

*AMERICAS Seagate Technology LLC 10200 South De Anza Boulevard, Cupertino, California 95014, United States, 408-658-1000*

*ASIA/PACIFIC Seagate Singapore International Headquarters Pte. Ltd. 7000 Ang Mo Kio Avenue 5, Singapore 569877, 65-6485-3888*

*EUROPE, MIDDLE EAST AND AFRICA Seagate Technology SAS 16-18 rue du Dôme, 92100 Boulogne-Billancourt, France, 33 1-4186 10 00*

*Publication Number: 100716627, Rev. H*

*August 2015*